

# UM Train 3D Module

## Contents

<b>17. UM TRAIN3D: 3D VEHICLE MODELS IN TRAIN.....</b>	<b>1-3</b>
<b>17.1. INTRODUCTION.....</b>	<b>1-3</b>
<b>17.2. DATABASE OF MODELS FOR TRAIN 3D MODULE .....</b>	<b>1-4</b>
<b>17.3. MODEL OF STANDARD AUTOMATIC COUPLER.....</b>	<b>1-7</b>
17.3.1. General information .....	1-7
17.3.2. Structure of automatic coupler model AC_Standard .....	1-9
17.3.2.1. Model structure .....	1-9
17.3.2.2. Bodies and joints.....	1-10
17.3.2.3. Draft gears .....	1-11
17.3.2.4. Interaction for coupler body.....	1-11
17.3.2.5. Interaction between two automatic couplers.....	1-13
17.3.2.6. Parameterization of automatic coupler model.....	1-14
17.3.3. AC_Standard_EXT_F(R) compared to AC_Standard .....	1-15
17.3.4. Model AC_Standard_EXT_F .....	1-15
17.3.5. Model AC_Standard_EXT_R.....	1-16
<b>17.4. STANDARD MODEL OF BUFFERS .....</b>	<b>1-17</b>
17.4.1. General information .....	1-17
17.4.2. Structure and detailed description of model Buffer .....	1-20
17.4.2.1. Model structure .....	1-20
17.4.2.2. Bodies and joints.....	1-20
17.4.2.3. Draft gears .....	1-22
17.4.2.4. External elements of interaction of two vehicles .....	1-24
17.4.3. Features of Buffer_EXT_F(R) models in comparison of Buffer .....	1-27
17.4.4. Model Buffer_EXT_F.....	1-28
17.4.5. Model Buffer_EXT_R .....	1-29
<b>17.5. STANDARD IDENTIFIERS AND TEXT ATTRIBUTES FOR COUPLING SYSTEMS.....</b>	<b>1-30</b>
<b>17.6. DEVELOPMENT OF 3D STRING OF VEHICLES.....</b>	<b>1-31</b>
17.6.1. Adding automatic couplers to 3D vehicle models.....	1-31
17.6.2. Three-unit 3D string for separate using .....	1-32
17.6.3. Three-unit 3D string for inclusion in a train model.....	1-35
<b>17.7. DEVELOPMENT OF TRAIN WITH INCLUDED 3D VEHICLE MODELS.....</b>	<b>1-37</b>
17.7.1. General information .....	1-37
17.7.2. Example of 3D train model .....	1-37
<b>17.8. SIMULATION OF TRAIN WITH INCLUDED 3D VEHICLES.....</b>	<b>1-40</b>
17.8.1. Positions of 3D vehicles in the train .....	1-40
17.8.2. Specifying track macrogeometry .....	1-41
17.8.3. Positioning of the first vehicle of train.....	1-42
<b>17.9. DEVELOPMENT OF TRAIN MODEL INCLUDING 3D VEHICLES ONLY .....</b>	<b>1-43</b>

# 1. UM TRAIN3D: 3D vehicle models in train

## 1.1. Introduction



Figure 1.1. String of 3D vehicles

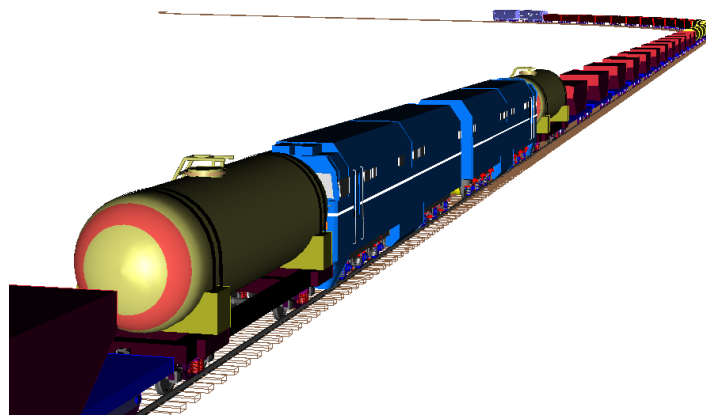

Figure 1.2. String of 3D vehicles in a train

**UM Train3D** module is a superstructure over the **UM Loco** and **UM Train** modules. It allows the user to create a string of 3D vehicles, Figure 1.1, as well as inserting any number of 3D models of rail vehicles in a train, Figure 1.2. In particular, a train model can include a 3D string of several cars and/or locomotives or it can be completely combined of 3D vehicles. Such models are often used for advanced analysis of rail vehicle dynamics taking into account in-train forces at various train operation modes.

The «+» sign in the **About** window indicates the availability of the Train 3D module in the current um configuration. The window is called by the **Help | About...** menu command, Figure 1.3.

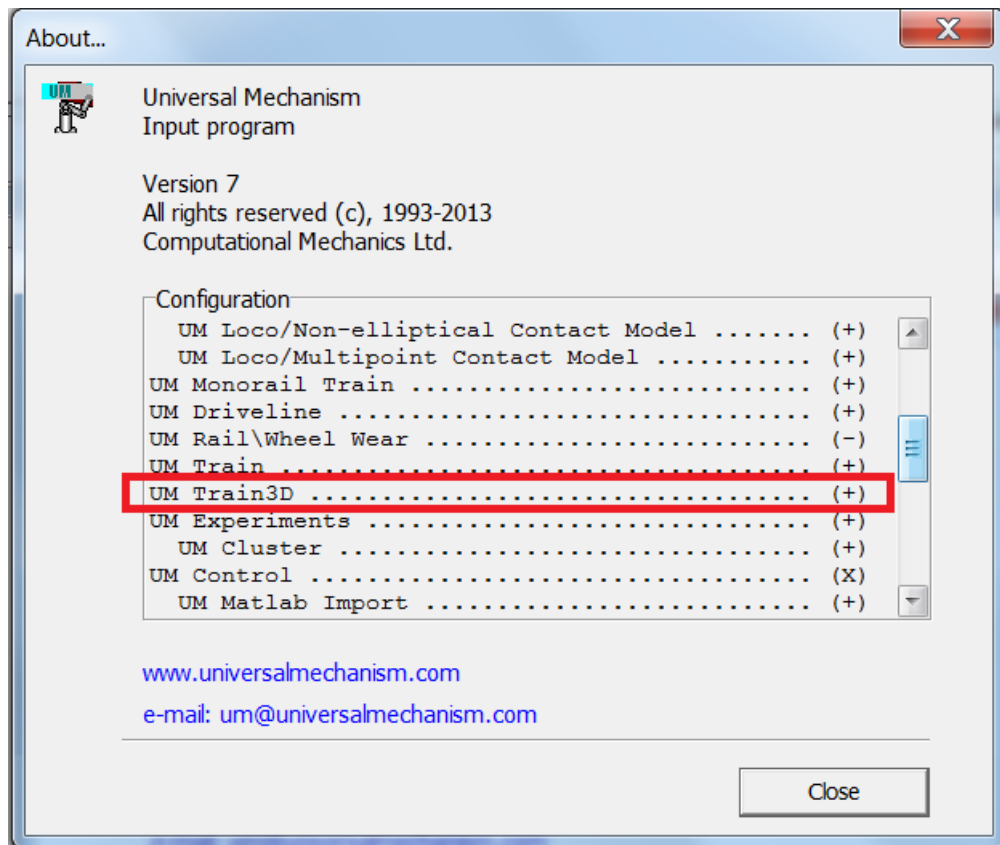

Figure 1.3. Presence of UM module in UM configuration

3D models of cars and locomotives must satisfy a number of requirements to be included in a train. For instance, models should include mechanical coupling systems (automatic couplers, buffers). Besides, braking mode must be provided for 3D vehicles, and traction modes for 3D models of locomotives.

**Remark.** The following abbreviations in element names are used for element identification:

- F* means front,
- R* means rear,
- L* means left,
- R* means right,
- EXT* means external.

## 1.2. Database of models for Train 3D module

A number of models related to Train 3D module are delivered with UM. The models are located in the *Samples\Train3D* directory and includes

- Automatic couplers and buffers,
- Models of a freight and passenger vehicles equipped with coupling systems,
- Models of string of 3D rail vehicles as well as trains including 3D vehicles.

The list of the models is presented in Table 1.1.

Table 1.1

**Models related to Train 3D module**

Name of model	Directory in folder Samples\Train3D	Comments
<i>AC_Standard</i>	Couplers	Standard models of Russian automatic couplers AC-3 for an internal vehicle of a string of 3D vehicles (Sect. 1.3.2. " <i>Structure of automatic coupler model AC_Standard</i> ", p. 1-9), as well as for the front and rear vehicle in a 3D string included in a train (Sect. 1.3.3. " <i>AC_Standard_EXT_F(R) compared to AC_Standard</i> ", p. 1-15).
<i>AC_Standard_EXT_F</i>		
<i>AC_Standard_EXT_R</i>		
<i>Buffer</i>		Standard models of buffer couplers for an internal vehicle of a string (Sect. 1.4.2. " <i>Structure and detailed description of model Buffer</i> ", p. 1-20), as well as for the front and rear vehicle in a string included in a train (Sect. 1.4.3. " <i>Features of Buffer_EXT_F(R) models in comparison of Buffer</i> ", p. 1-27).
<i>Buffer_EXT_F</i>		
<i>Buffer_EXT_R</i>		
<i>Simple_18_100_AC_Std</i>	Subsystems	Simplified models of a freight car with three piece bogies equipped with automatic couplers for including in a 3D string (Sect. 1.6. " <i>Development of 3D string of vehicles</i> ", p. 1-31)
<i>Simple_18_100_AC_ExtF</i>		
<i>Simple_18_100_AC_ExtR</i>		
<i>FreightCar_18_100_3Vehicles_ExtRF</i>		Model of string of three freight cars for inclusion in a train model, Sect. 1.6.3. " <i>Three-unit 3D string for inclusion in a train model</i> ", p. 1-35.
<i>Passenger Car</i>		Models of a passenger rail vehicles from Manchester benchmarks equipped with buffers couplers for inclusion in 3D strings (Sect. 1.4.1.
<i>Passenger Car ExtF</i>		
<i>Passenger Car ExtR</i>		

		<i>"General information"</i> , p. 1-17)
<i>Passenger Car 3VehiclesExtRF</i>		Model of a tree-vehicle string for inclusion in a train (Sect. 1.6.3. <i>"Three-unit 3D string for inclusion in a train model"</i> , p. 1-35)
<i>Co_Co_Buffers</i>		Model of a passenger electric locomotive equipped with buffer couplers, Sect. 1.9. <i>"Development of train model including 3D vehicles only"</i> , p. 1-43.
<i>Freight train</i>	Directly in folder Samples\Train3D	Model of a freight train containing 60 vehicles and including a 3D string of tree vehicles, Sect. 1.8. <i>"Simulation of train with included 3D vehicles"</i> , p. 1-40.
<i>FreightCar_18_100_3Vehicles</i>		String of 3 freight vehicles for simulation outside of a train, Sect. 1.6.2. <i>"Three-unit 3D string for separate using"</i> , p. 1-32.
<i>Passenger train (three 3D cars)</i>		Model of a passenger train containing 20 vehicles and including a 3D string of tree vehicles, Sect. 1.8. <i>"Simulation of train with included 3D vehicles"</i> , p. 1-40.
<i>Passenger train 3D</i>		Model of a passenger train containing 20 3D vehicles, Sect. 1.9. <i>"Development of train model including 3D vehicles only"</i> , p. 1-43.

**Remark.** The following models are available for simulation  
 Freight train  
 FreightCar\_18\_100\_3Vehicles  
 Passenger train (three 3D cars)  
 Passenger train 3D

Other models are auxiliary. The **Subsystems** directory includes models included in the above models as external subsystems. The models of coupling elements form the **Couplers** directory serve for information purpose; they can be used as a base for the user's developments.

## 1.3. Model of standard automatic coupler

### 1.3.1. General information



Figure 1.4. Visual components for automatic couplers (selected by box)

Models of Russian automatic couplers are delivered with UM Train3D. The models allow the user to develop easily 3D rail vehicle models for their use in a train or in a separate string models. The coupler models are presented either as visual components on the UM Loco sheet (Figure 1.4) or as UM objects (Sect. 1.2. "Database of models for Train 3D module", p. 1-4)

*AC\_Standard* is used for vehicles including in a string, the visual component icon ;

*AC\_Standard\_EXT\_F* is used for a leading vehicle of a string including in a train, the visual component icon .

*AC\_Standard\_EXT\_R* is used for a trailing vehicle of a string including in a train, the visual component icon .

Models of automatic couplers delivering with UM can be used as templates for development of alternative models by the user.

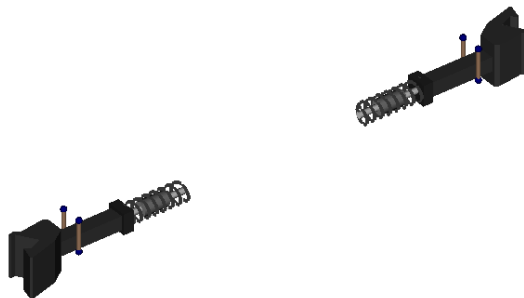

Figure 1.5. Model of automatic couplers, UM object *AC\_Standard*



Figure 1.6. Models of automatic couplers, UM objects *AC\_Standard\_EXT\_F*, *AC\_Standard\_Ext\_R* (rotated by 180 degrees)

General view of automatic coupler models are shown in Figure 1.5, Figure 1.6. As it is shown in Figure 1.6, the models *AC\_Standard\_EXT\_F*, *AC\_Standard\_Ext\_R* contain additional coupler elements (in front part for *AC\_Standard\_EXT\_F* and in rear part for *AC\_Standard\_Ext\_R*), which will be assigned automatically to simplified 1D models of vehicles in a train.

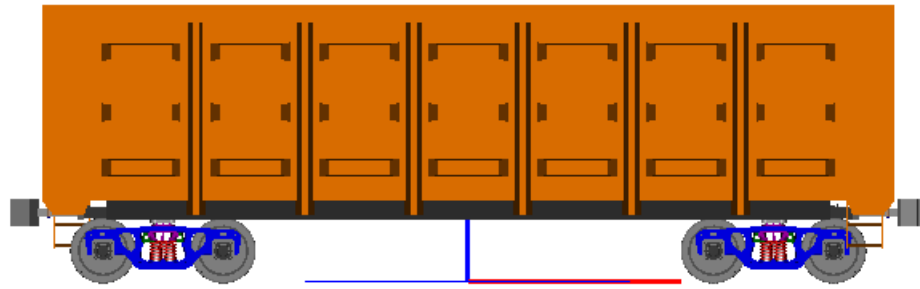

Figure 1.7. Model *simple\_18\_100\_AC\_Std* of a freight vehicle with automatic coupler system according to the model *AC\_Standard*

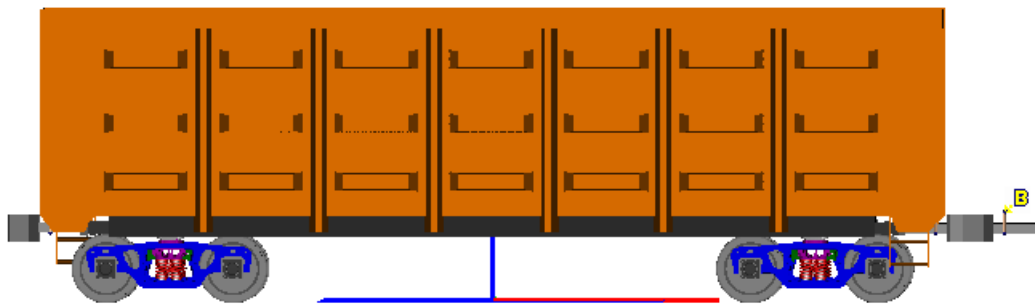

Figure 1.8. Model *simple\_18\_100\_AC\_ExtF* of a freight vehicle with automatic coupler system according to the model *AC\_Standard\_EXT\_F*

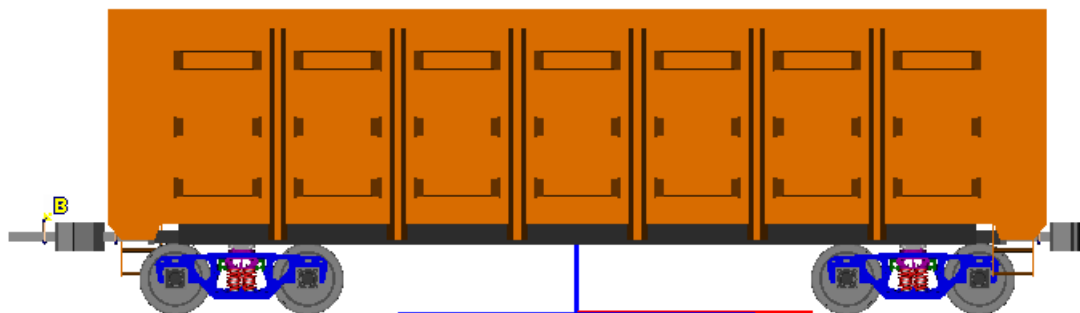

Figure 1.9. Model *simple\_18\_100\_AC\_ExtR* of a freight vehicle with automatic coupler system according to the model *AC\_Standard\_EXT\_R*

Figure 1.7 shows the 3D model of a rail car for including in a vehicle string model. The models in Figure 1.8, Figure 1.9 are designed for including in a train as a leading and trailing units coupled to a 1D vehicles.

### 1.3.2. Structure of automatic coupler model AC\_Standard

#### 1.3.2.1. Model structure

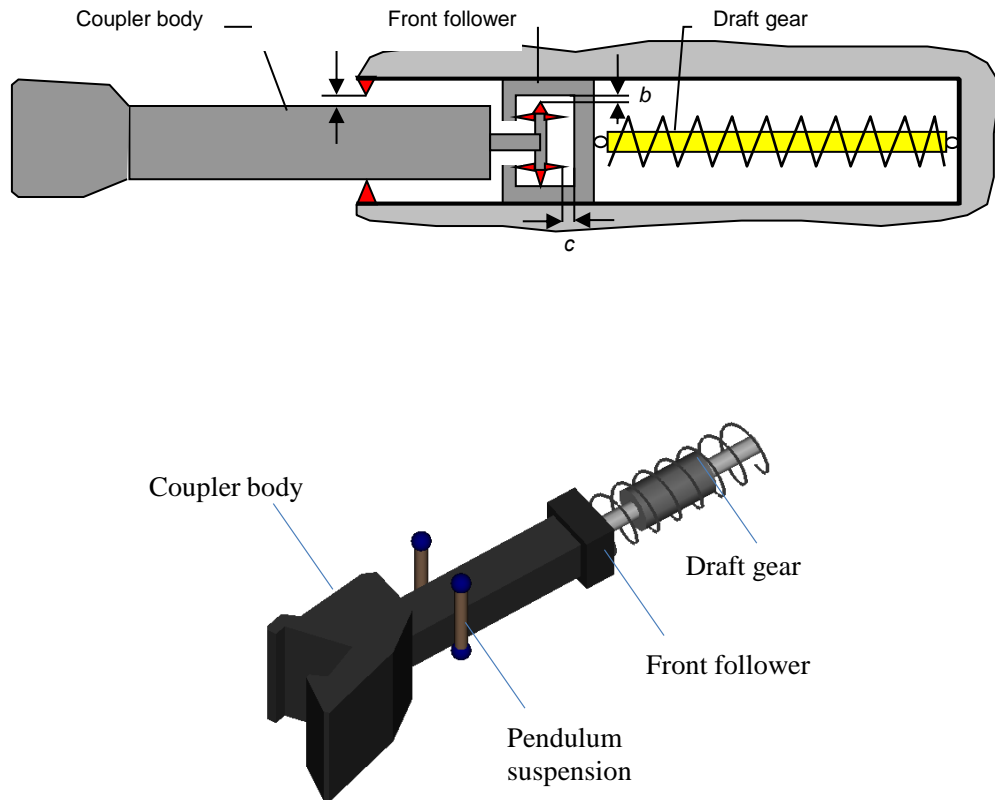

Figure 1.10. Elements of automatic coupler model

Model of Russian automatic coupler includes (Figure 1.10):

- *Coupler body* is a rigid body with 6 d.o.f. supplied by a set of contact elements describing interactions of other bodies taking into account clearances.
- *Front follower* is a rigid body having one translational degree of freedom relative to the car body.
- *Draft gear* is a bilateral force element attached to the follower and the car body.
- Pendulum suspension imitates the aligning device. It consists of two bipolar force elements.

**1.3.2.2. Bodies and joints**

The *AC\_Standard* model contains 5 bodies and 6 joints described in Table 1.2, Table 1.3.

Table 1.2

**Bodies in the AC\_Standard model**

Name	Mass	Moments of inertia			Comments
		I <sub>x</sub>	I <sub>y</sub>	I <sub>z</sub>	
<i>CarBodyFixed</i>	0	0	0	0	This is a fictitious body for connection of model elements. After merging the model to the vehicle this body is rigidly connected with the car body. The <i>CarBodyFixed</i> body is created with an internal 6 d.o.f. joint.
<i>AC body F(R)</i>	<i>Mac</i>	<i>Iacx</i>	<i>Iacy</i>	<i>Iacz</i>	Front (rear) coupler body.
<i>Plate AC F(R)</i>	<i>mPlateAC</i>	0	0	0	Followers of the front (rear) automatic couplers

Table 1.3

**Joints in the AC\_Standard model**

Name	Type	Number of d.o.f.	Body 1	Body 2	Comments
<i>CarBodyFixed</i>	Internal	6	<i>Base 0</i>	<i>CarBodyFixed</i>	Internal joint of the <i>CarBodyFixed</i> body. The joint is automatically removed after assigning the second body to the <i>jCarBodyFix</i> joint
<i>jCarBodyFix</i>	Generalized	0	<i>CarBodyFix</i>	<i>External</i>	The joint connects rigidly the fictitious body with the car body
<i>jAC body F(R)</i>	6 d.o.f.	6	<i>Base 0</i>	<i>AC body F</i>	The joints assign coordinates of front (rear) coupler body
<i>jPlate AC F(R)</i>	Translational	1	<i>Plate AC F</i>	<i>CarBodyFixed</i>	The joint specifies the translational motion of the front (rear) follower relative to the fictitious body (in fact, relative to the car

					body)
--	--	--	--	--	-------

A connection point with the relative coordinates (0,0,0) is assigned to the AC body F body. The point is used for setting a connection between this body and the rear coupler body of the neighbor vehicle in the train (see. Sect. 1.6.2. "Three-unit 3D string for separate using", p. 1-32).

### 1.3.2.3. Draft gears

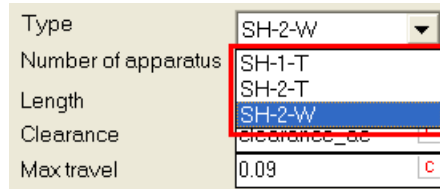

Figure 1.11. Choice of draft gear

Two draft gears *Draft gear F(R)* are modeled by bipolar force elements connecting the fictitious body *CarBodyFixed* and followers *Plate AC F(R)*. The force model is bilateral and symmetric working both on compression and stretching. By default, the draft gear model *SH-2-W* is assigned. The user can select other type of draft gears, Figure 1.11.

### 1.3.2.4. Interaction for coupler body

1. Interaction coupler body / follower.

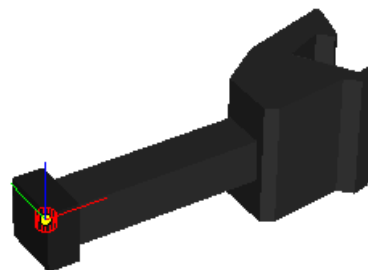

Figure 1.12. Element "Bushing AC body F"

- *Bushing AC body F(R)* is an element of *Bushing* type. The element fixes the tailing part of the coupler body relative to the follower in the lateral direction, in the vertical direction with the gap  $gap_z = 0.024$  m as well as by rotation about the longitudinal direction (roll) with the gap parameterized by the identifier  $gap_{ax} = 0.03$  rad, Figure 1.12.

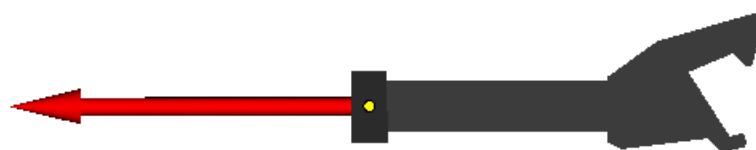

Figure 1.13. Contact element "Longitudinal contact F"

- *Longitudinal contact F(R)* is a contact force element of “points-plane” type. The element sets a bilateral contact with friction between the coupler body and the follower. The contact point belongs to the tailing part of the coupler body. It slides with friction over the vertical plane connected with the follower, Figure 1.13.

2. Interaction coupler body / fictitious body *CarBodyFixed* (with car body).

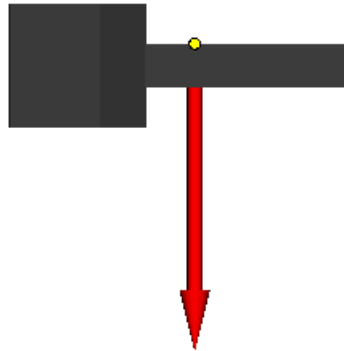

Figure 1.14. Contact element “Upper support F”

- *Upper support F(R)* is a contact force element of the “points-plane” type. It makes limit for shift of the middle part of the coupler body in vertical direction with the gap  $gap\_z\_front = 0.024$  m, Figure 1.14. In addition, it limits body rotation about the lateral axis.

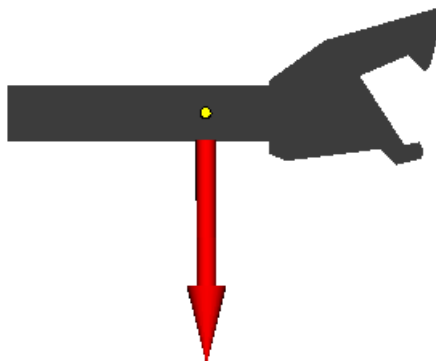

Figure 1.15. Contact element “Lateral gap F”

- *Lateral gap F(R)* is a contact element of the “points-plane” type. It limits lateral shift of the middle part of the coupler body with the gap  $gap\_y = 0.05$  m for a side as well as rotation about the vertical axis, Figure 1.15.



Figure 1.16. Bipolar force “Pendulum suspension FL”

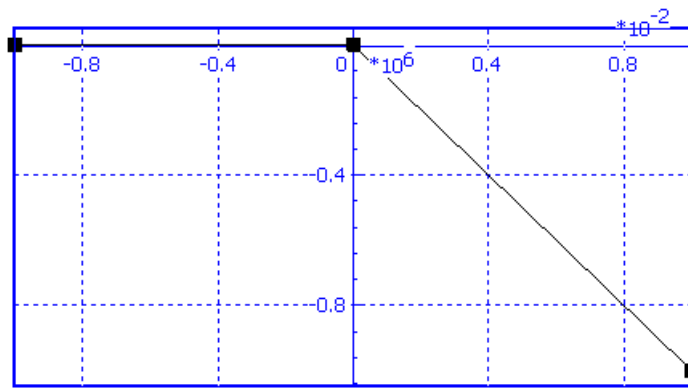

Figure 1.17. Plot of unilateral elastic component of bipolar force element

- *Pendulum suspension F(R)L(R)* is a pair of unilateral viscous-elastic bipolar force elements building the pendulum suspension. This suspension models the aligning device, Figure 1.16. The force element works at stretching. Plot for elastic component of the force element is shown in Figure 1.17. The dissipative component is set by the expression

$$-cdisscontz*v*heavi(x-l_pov),$$

Where *heavi* is the Heaviside step function, *cdisscontz* is the damping constant, *l\_pov* is the element length in unloaded state, *x* is the variable length of the element.

$$heavi(x) = \begin{cases} 1, & x > 0 \\ 0, & x \leq 0 \end{cases}$$

### 1.3.2.5. Interaction between two automatic couplers

Interaction between the rear coupler and the front one of the next vehicle is described by two force elements. The elements are *external*, i.e. the second body in the force element description is External and should be assigned with the help of a special tool by development of a string model, Sect. 1.6.2. *"Three-unit 3D string for separate using"*, p. 1-32.

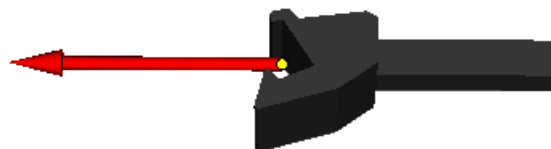

Figure 1.18. External element: longitudinal contact of coupler bodies

- *Longitudinal AC body contact* is a contact element of the “points-plane” type. The element is used for transfer of longitudinal in-train forces, Figure 1.18. The element produces a vertical friction force proportional to the longitudinal force by vertical relative movement of bodies.

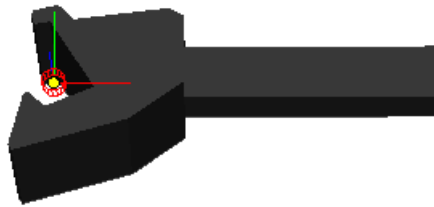

Figure 1.19. External element: limitation of relative motion of coupler bodies

- *Bushing AC R-F* is an external special force element of the “Bushing” type. The element introduces limitations for all three rotations, in the lateral and vertical directions, Figure 1.19. Vertical motion is limited with a gap  $z\_ac\_shift\_max = 0.1$  m for a side.

**Remark.** The standard text attribute `LongitudinalForceR` is assigned to the force element `Longitudinal AC body contact`. In such a way the program is informed that this element will be used for evaluation of longitudinal force in the coupling system by simulation of the vehicle included in the train.

### 1.3.2.6. Parameterization of automatic coupler model

Name	Expression	Value	Comment
CouplingHeight	1.06		z coordinate of coupler over rail level
VehicleBase	8.65		Pivot base of vehicle
CouplingBase	5		Coupling base of vehicle
couplinglength	2		Length of two coupler bodies
mPlateAC	500		Mass of follower
mac	250		Mass of coupler body
iacx	20		Moment of inertia of coupler body X
iacy	100		Moment of inertia of coupler body Y
gap_z_front	0.024		Vertical gap for coupler body (front part)
gap_y	0.05		Lateral gap for coupler body (middle part)
gap_ax	0.03		Angular X gap for coupler body
gap_z	0.024		Vertical gap for coupler body (tailing part)
z_ac_shift_max	0.1		Maximal relative vertical shift of pair of coupler bodies for a side
l_pov	0.3		Length of pendulum suspension
cstiffcontz	1.0000000E+8		Contact stiffness Z, Y
cstiffcontx	1.0000000E+9		Longitudinal contact stiffness X
cstiff_az	1.0000000E+5		Angular contact stiffness
cdisscontz	1.0000000E+4		Contact damping Z, Y
cdisscontx	1.0000000E+6		Contact damping X
cdiss_az	1000		Angular contact damping
ac_cg	0.4		Longitudinal position of coupler body CG
nfront_dg	1		Number of front draft gears
nrear_dg	1		Number of rear draft gears

Figure 1.20. List of identifiers parameterizing the automatic coupler model

A number of identifiers are used for geometric, inertia and force parameters, Figure 1.20.

### 1.3.3. AC\_Standard\_EXT\_F(R) compared to AC\_Standard

As it is written in Sect. 1.3.1. "General information", p. 1-7, the *AC\_Standard\_EXT\_F(R)* models are designed for equipping 3D models of rail vehicles by automatic couplers in case including the vehicles in train formations. Apart from 3D vehicles, a train model may include any number of 1D vehicles interconnected by means of simplified coupling systems. To make simulation of 3D string in the train more accurate, the connection between the front or rear 3D vehicles with neighbor 1D units is realized by advanced models of automatic couplers described in Sect. 1.3.2. "Structure of automatic coupler model *AC\_Standard*", p. 1-9. Thus, the *AC\_Standard\_EXT\_F(R)* compared to the *AC\_Standard* model contain additional elements, in particular coupler bodies and a number of force elements which are attached automatically to neighbor 1D vehicles.

### 1.3.4. Model AC\_Standard\_EXT\_F

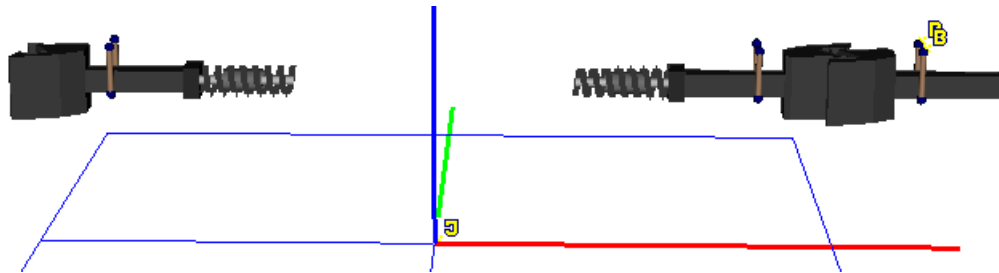

Figure 1.21. Model *AC\_Standard\_EXT\_F*

The *AC\_Standard\_EXT\_F* model is developed for equipping by automatic couplers the **front** vehicle of a 3D string under the assumption that it is not the first vehicle in the train. Compared to the *AC\_Standard*, this model contains the following additional elements and modifications, see the right hand side of Figure 1.21:

- Body *AC body F Ext* is the additional coupler body.
- *Joint jAC body F Ext* introduces 6 d.o.f. of the additional body relative to Base0.
- Bipolar force elements *Pendulum suspension FL(FR) Ext* define the pendulum suspension for an aligning device.
- External force elements *Upper support F Ext*, *Lateral gap F Ext*, *Longitudinal contact F Ext* specify limitations in motion of additional coupler body relative to the car body.
- Contact force element *Longitudinal AC body contact F* transfers the longitudinal force between the couplers. An analogous element for the rear automatic coupler is the force element *Longitudinal AC body contact*, Sect. 1.3.2.5. "Interaction between two automatic couplers", p. 1-13.
- Special force *Bushing AC F-R* limits relative motion of coupler bodies *AC Body F Ext* and *AC Body F*. The analogous element is *Bushing AC R-F*, Sect. 1.3.2.5. "Interaction between two automatic couplers", p. 1-13.

- Special force element *Bushing AC body F Ext* is used for fixing the tailing part of the *AC body F Ext* body relative to the 1D vehicle.
- The *nfront\_dg* identifier (number of front draft gears) is equal to 2 instead of 1. Draft gear models SH2-W, SH-2-T, SH-1-T allow modeling several sequential draft gears.

**Remark 1.** Description of these elements is similar to that of internal elements having analogous names. For instance, the *Bushing AC body F Ext* force element is similar to the *Bushing AC body F(R)* ones.

**Remark 2.** It is important that the test attribute *CouplingExtFront* is assigned to the force elements *Pendulum suspension FL(FR) Ext*, *Upper support F Ext*, *Lateral gap F Ext*, *Longitudinal contact F Ext*, *Bushing AC body F Ext*. This attribute enables an automatic assignment of external second bodies to the elements.

### 1.3.5. Model AC\_Standard\_EXT\_R

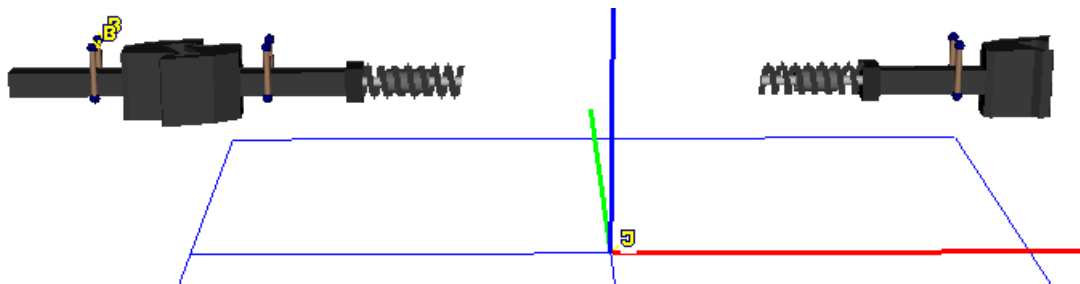

Figure 1.22. Model AC\_Standard\_EXT\_R

The *AC\_Standard\_EXT\_R* model is developed for equipping by automatic couplers the **rear** vehicle of a 3D string under the assumption that it is not the last vehicle in the train. Compared to the *AC\_Standard*, this model contains the following additional elements and modifications, see the left hand side of Figure 1.22.

- Body *AC body R Ext* is the additional coupler body.
- Joint *jAC body R Ext* introduces 6 d.o.f. of the additional body relative to Base0.
- Bipolar force elements *Pendulum suspension RL(RR) Ext* define the pendulum suspension for an aligning device.
- External force elements *Upper support R Ext*, *Lateral gap R Ext*, *Longitudinal contact R Ext* specify limitations in motion of additional coupler body relative to the car body.
- Force element *AC body contact* transfers the longitudinal force between coupler bodies. The special force element *Bushing AC F-R* limits the relative motion of coupler bodies. Unlike the *AC\_Standard* model, these both elements are internal, and the second body in force element descriptions is *AC body R Ext*.
- Special force element *Bushing AC body R Ext* is used for fixing the tailing part of the *AC body R Ext* body relative to the 1D vehicle.
- The *nrear\_dg* identifier (number of rear draft gears) is equal to 2 instead of 1. Draft gear models SH2-W, SH-2-T, SH-1-T allow modeling several sequential draft gears.

- Remark 1.** Description of these elements is similar to that of internal elements having analogous names. For instance, the *Bushing AC body R Ext* force element is similar to the *Bushing AC body F(R)* ones.
- Remark 2.** It is important that the test attribute *CouplingExtRear* is assigned to the force elements *Pendulum suspension RL(RR) Ext*, *Upper support R Ext*, *Lateral gap R Ext*, *Longitudinal contact R Ext*, *Bushing AC body R Ext*. This attribute enables an automatic assignment of external second bodies to the elements.

## 1.4. Standard model of buffers

### 1.4.1. General information



Figure 1.23. Visual components of buffer coupling systems (selected by a rectangle)

Simplified models of buffer couplers are delivered with UM Train3D. The models allow the user to finish 3D rail vehicle models for their use in a train or in a connection models. The coupler models are presented either as visual components on the UM Loco sheet, Figure 1.27, or as UM objects

*Buffer* is used for vehicles including in a 3D string;

*Buffer\_EXT\_F* is used for a leading vehicle of a 3D string including in a train;

*Buffer\_EXT\_R* is used for a trailing vehicle of a 3D string including in a train.

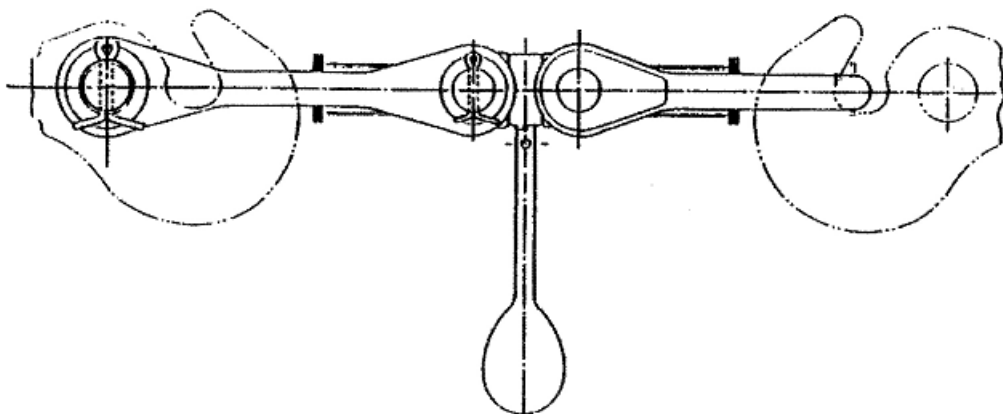

Figure 1.24. Drawgear

The simplification of the model concerns those of elements coupling vehicles, which are not buffers. For example, they can be automatic couplers or draw hooks, Figure 1.24. Detailed description of the automatic coupler model is given in previous section. That is why we consider here a simplified draw connection working on stretching only.

Models of automatic couplers delivered with UM can be used as templates for development of alternative models by the user.

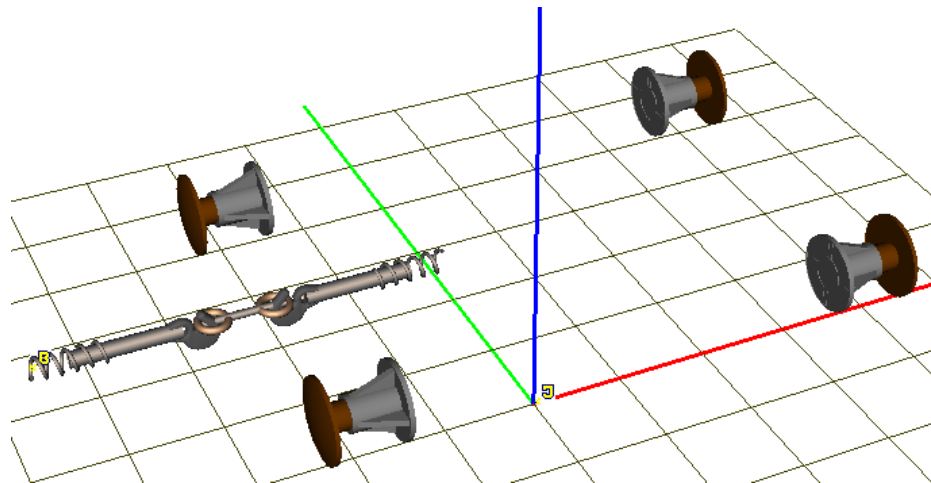

Figure 1.25. Model of buffer coupling system, UM object *Buffer*

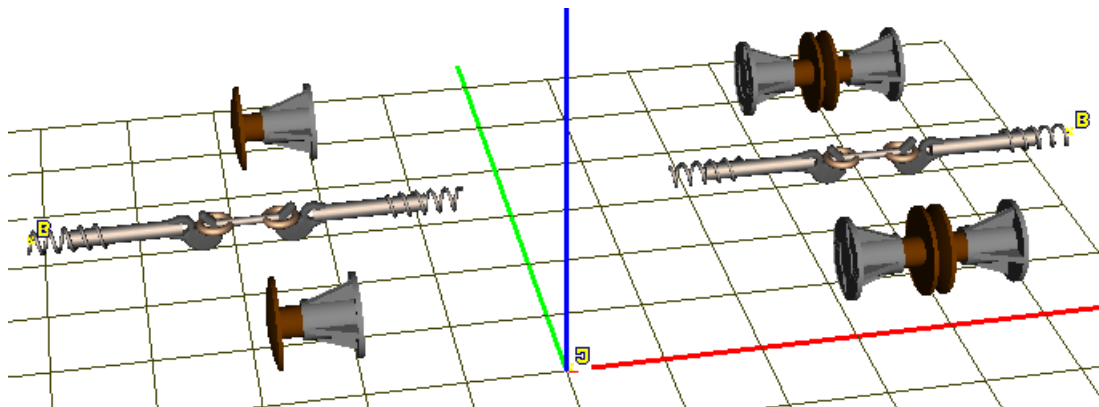

Figure 1.26. Model of buffer coupling system, UM object *Buffer\_Ext\_F*

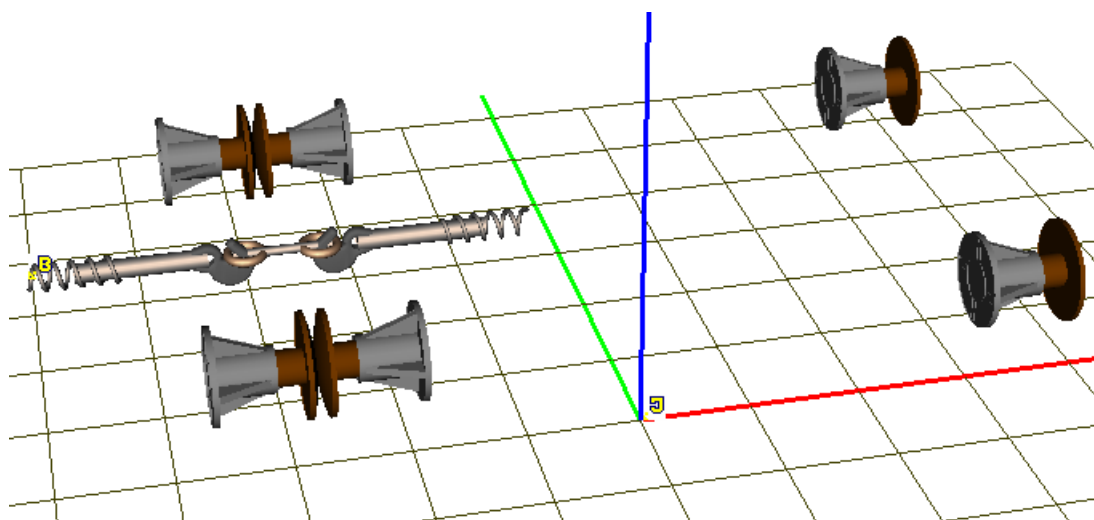

Figure 1.27. Model of buffer coupling system, UM object *Buffer\_Ext\_R*

Figure 1.25, Figure 1.26, Figure 1.27 show buffer coupling system models. As it is shown in Figure 1.26, Figure 1.27 the models *Buffer\_EXT\_F*, *Buffer\_Ext\_R* contain additional coupler el-

elements (in front part for *Buffer\_EXT\_F* and in rear part for *Buffer\_Ext\_R*), which will be assigned automatically to simplified 1D models of vehicle in a train.

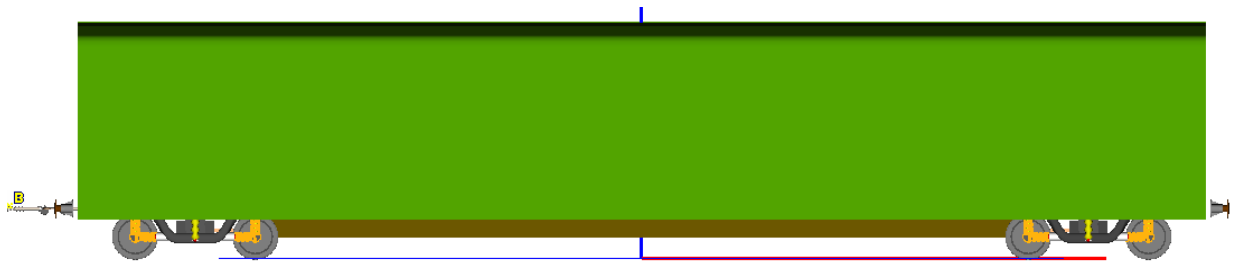

Figure 1.28. Model Passenger Car equipped with coupling system with the help of *Buffer* model

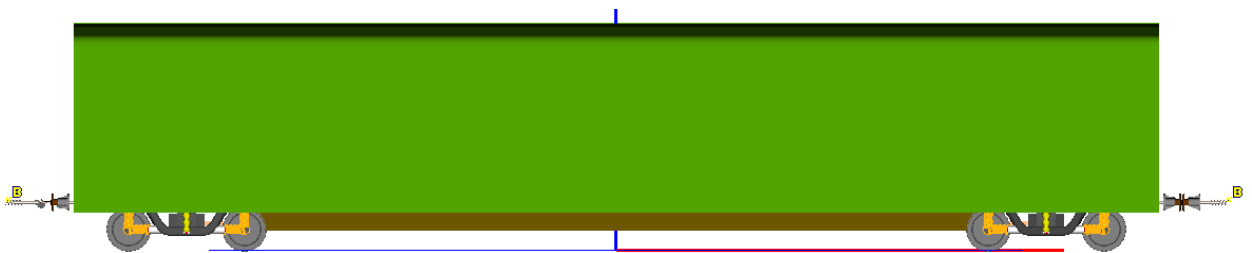

Figure 1.29. Model Passenger Car ExtF equipped with coupling system with the help of *Buffer\_EXT\_F* model

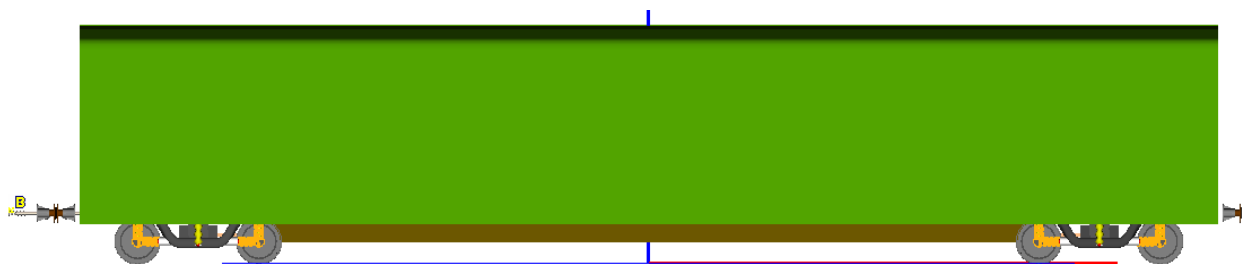

Figure 1.30. Model Passenger Car ExtR equipped with coupling system with the help of *Buffer\_EXT\_R* model

Figure 1.28 shows the 3D model of a rail car for including in a string model. The models in Figure 1.29, Figure 1.30 are designed for including in trains as a leading and trailing unit of a string coupled with a 1D vehicle.

### 1.4.2. Structure and detailed description of model Buffer

#### 1.4.2.1. Model structure

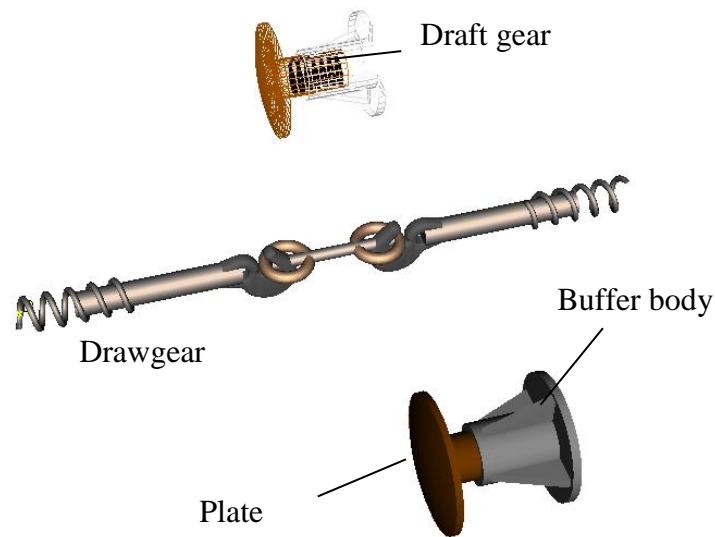

Figure 1.31. Structure of model

The model of buffer coupling system includes the following elements (Figure 1.31):

- *Buffer body* is a rigid body rigidly connected with the car body.
- *Buffer plate* is a rigid body with one translational degree of freedom relative to the buffer body.
- *Draft gear* is a force element between the plate and the buffer body.
- *Drawgear* is a unilateral bipolar force element working on stretching.

#### 1.4.2.2. Bodies and joints

The Buffer model includes 9 bodies and 10 joints described in Table 1.4, Table 1.5.

Table 1.4

**Bodies in model Buffer**

Name	Mass	Moments of inertia			Comments
		I <sub>x</sub>	I <sub>y</sub>	I <sub>z</sub>	
<i>CarBodyFixed</i>	0	0	0	0	This is a fictitious body for connection of model elements. After merging the model to the vehicle this body is rigidly connected with the car body. The CarBodyFixed body is created with an internal 6 d.o.f. joint.
<i>Buffer body RL</i>	<i>m_buffer_bod</i>	0	0	0	Buffer bodies

<i>(RR, FL, FR)</i>	<i>y</i>				
<i>Buffer plate RL</i> <i>(RR, FL, FR)</i>	<i>m_buffer_plate</i> <i>e</i>	0	0	0	Buffer plates

Table 1.5

**Joints in model Buffer**

<b>Name</b>	<b>Type</b>	<b>N of d.o.f</b>	<b>Body 1</b>	<b>Body 2</b>	<b>Comments</b>
<i>Car-BodyFixed</i>	internal	6	<i>Base 0</i>	<i>CarBodyFixed</i>	Internal joint of the <i>CarBodyFixed</i> body. The joint is automatically removed after assigning the second body to the <i>jCar-BodyFix</i> joint
<i>jCarBodyFix</i>	generalized	0	<i>CarBodyFix</i>	<i>External</i> (внешнее)	The joint connects rigidly the fictitious body with the car body
<i>jBuffer body RL</i> <i>(RR, FL, FR)</i>	6 d.o.f.	0	<i>Car-BodyFixed</i>	<i>Buffer body RL</i> <i>(RR, FL, FR)</i>	Set positions of buffer bodies relative to the car body
<i>jBuffer plate RL</i> <i>(RR, FL, FR)</i>	Translational	1	<i>Buffer body RL</i> <i>(RR, FL, FR)</i>	<i>Buffer plate RL</i> <i>(RR, FL, FR)</i>	The joints specify the translational motion of the front (rear) buffer plates relative to the buffer bodies

1.4.2.3. Draft gears

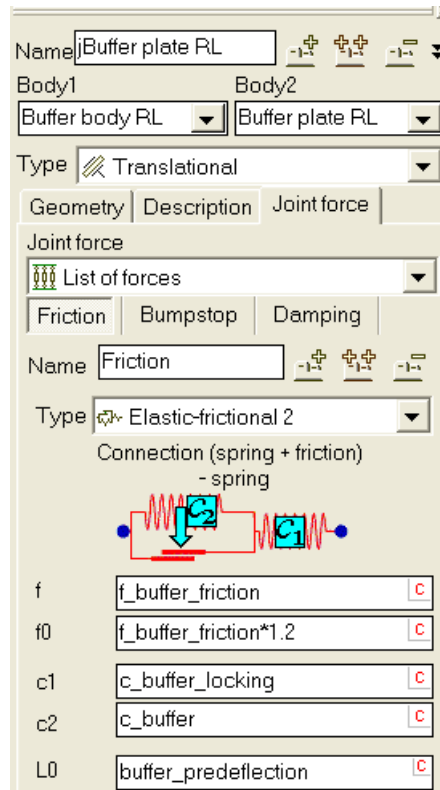

Figure 1.32. Draft gear friction model

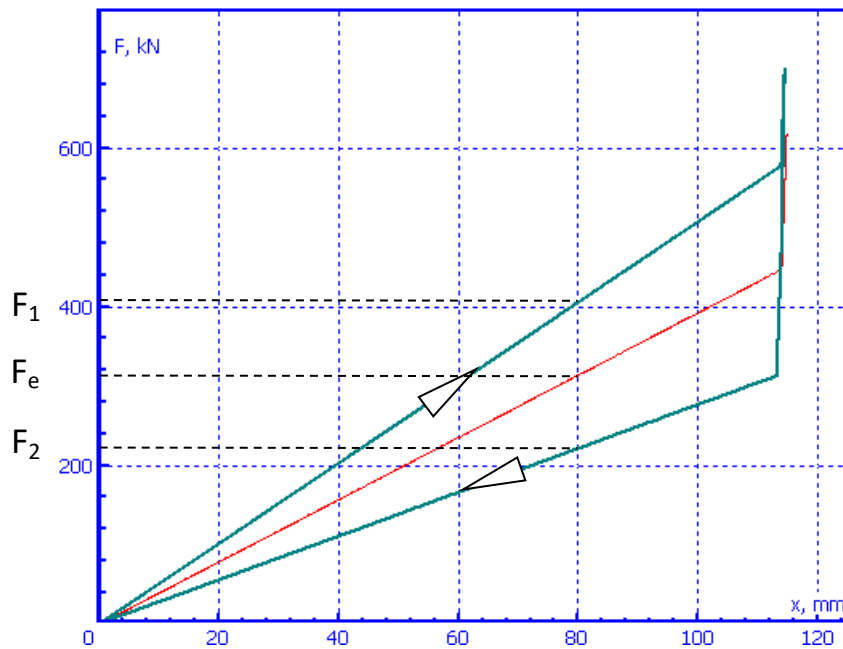

Figure 1.33. Draft gear hysteresis

Draft gears are modeled by joint forces in translational joints *jBuffer plate RL* (*RR, FL, FR*). List of forces describing the draft gear includes three components.

- Friction, Figure 1.32, Figure 1.33, the force type is «elastic – frictional 2». This is a friction, which depends on load of the spring **C2** with parameterized stiffness  $c\_buffer$ . Detailed description of the force can be found in [Chapter 2](#), Sect. *Elastic-frictional force 2*.

Spring **C1** has the stiffness constant  $c\_buffer\_locking$  much greater than  $c\_buffer$  and corresponds to the stiffness in sticking state. The coefficient  $f\_buffer\_friction$  specifies the friction force value according to the formula

$$F_{fr} = f\_buffer\_friction * c\_buffer * x,$$

where  $x$  is the deflection of spring **C2**.

Consider the force value for some definite deflection of the draft gear, Figure 1.33. In cases of compression and stretching the force is equal to

$$F_1 = F_e + F_{fr} = F_e + \mu c_2 x \approx c_2 x (1 + \mu),$$

$$F_2 = F_e - F_{fr} = F_e - \mu c_2 x \approx c_2 x (1 - \mu),$$

where  $F_e, \mu$  is the elastic component of the force and the coefficient of friction. The coefficient of friction is approximately equal to the coefficient of relative friction computed according to the formula

$$\varphi = \frac{F_1 - F_2}{F_1 + F_2}.$$

The draft gear preliminary deflection is set by the identifier  $buffer\_predeflection$  (m).

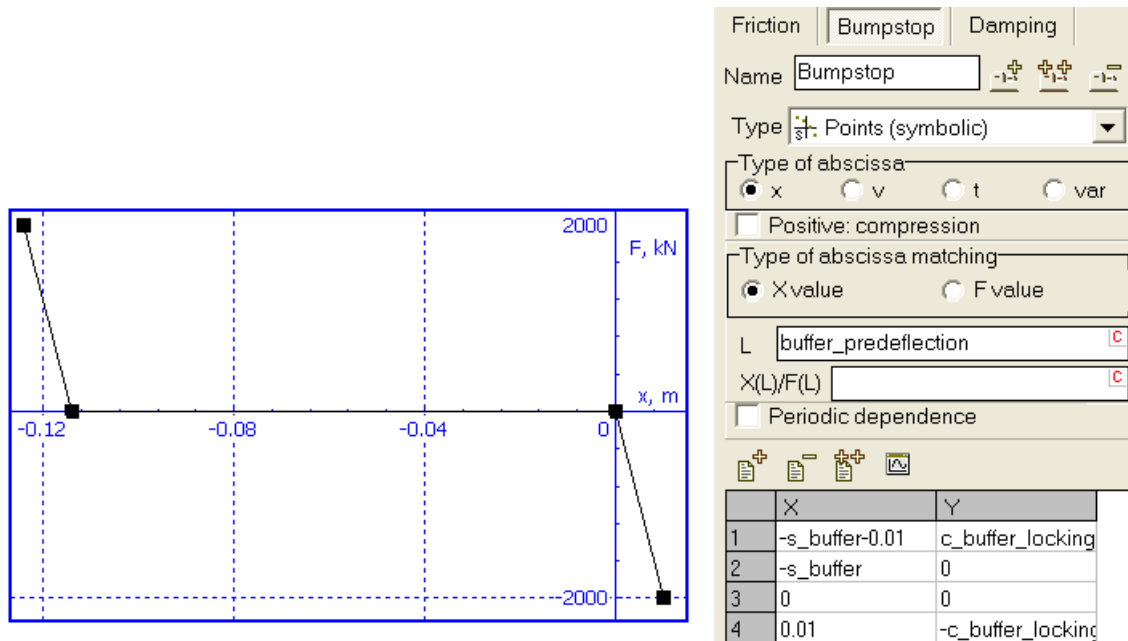

Figure 1.34. Limitation in the draft gear travel

- The second component of the draft gear model sets limits in the device travel. The maximal value of the buffer travel is parameterized by the identifier  $s\_buffer$ , Figure 1.34. Fast growth of the force in Figure 1.33 corresponds to this component.

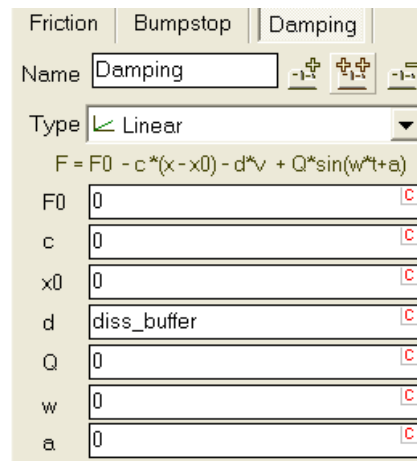

Figure 1.35. Linear damping

- The third component in the force list introduces a small linear damping, Figure 1.35. The damping constant is set by the identifier *diss\_buffer*.

**Remark.** A hysteresis curve of the draft gear as well as its travel limitation can be set with the help of the **Hysteresis** type of friction force. See the User’s Manual, [Chapter 2](#), Sect. **Force elements | Types of scalar forces | Hysteresis**.

**1.4.2.4. External elements of interaction of two vehicles**

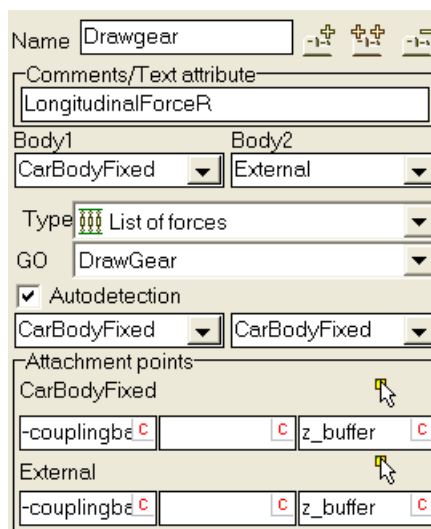
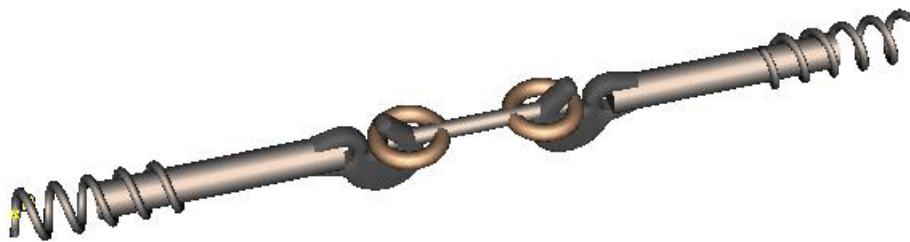

Figure 1.36. Draw gear element

Interaction of rear elements of the coupling system with the front elements of the neighbor vehicle is described by three force elements. The second body for these elements is specified as *External*. The real body should be assigned to the elements with the help of a special tool by creation of 3D string, Sect. 1.6.2. "*Three-unit 3D string for separate using*", p. 1-32).

Table 1.6

**Identifiers parameterizing drawgear**

Name	Default value	Comments
$l_{drawgear}$	2 m	Full length of drawgear
$z_{buffer}$	1.054 m	Height of buffers and drawgear over the rail head
$c_{drawgear}$	4x106 N/m	Drawgear stiffness by stretching
$d_{drawgear}$	1x104 Ns/m	Drawgear damping constant by stretching

1. *Draw gear* is a bipolar force element containing two components in parallel, Figure 1.36. The element connects *CarBodyFixed* with an external body in the *Autodetection* mode. The autodetection mode means that coordinates of attachment points for the second body are computed automatically after assignment of the body.

Coordinates of attachment points to *CarBodyFixed*:

$$(-couplingbase/2+l_{drawgear}/2, 0, z_{buffer}),$$

coordinates of attachment point to the second body in coordinate system of *CarBodyFixed*:

$$(-couplingbase/2-l_{drawgear}/2, 0, z_{buffer}).$$

Identifiers parameterizing these coordinates are collected in Table 1.6.

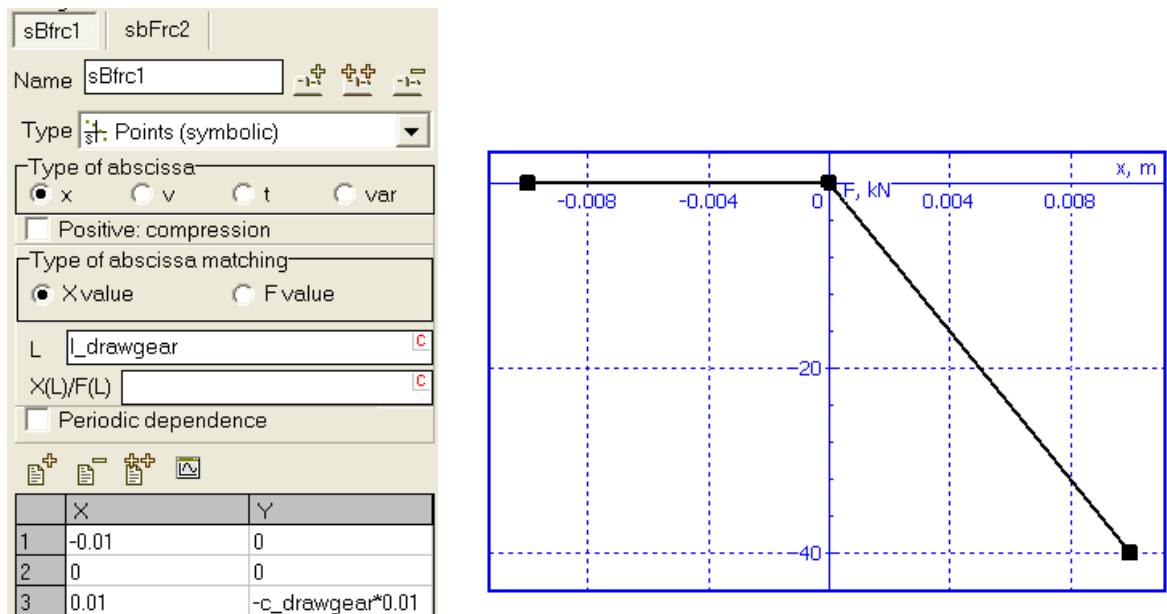

Figure 1.37. External element: draw gear working on stretching. Elastic component

The force element contains two components in parallel. The first one is an elastic force working on stretching only, Figure 1.37,

The second component is a dissipative force computed according to the formula

$$F = -d\_drawgear * v * heavi(x - l\_drawgear),$$

where  $d\_drawgear$  is the damping constant,  $v$ ,  $x$  are the element length and its velocity,  $l\_drawgear$  is the element length in unloaded state,  $heavi$  is the Heaviside step function,

$$heavi(x) = \begin{cases} 1, & x > 0 \\ 0, & x \leq 0 \end{cases}$$

The list of identifiers parameterizing the *drawgear* is collected in Table 1.6.

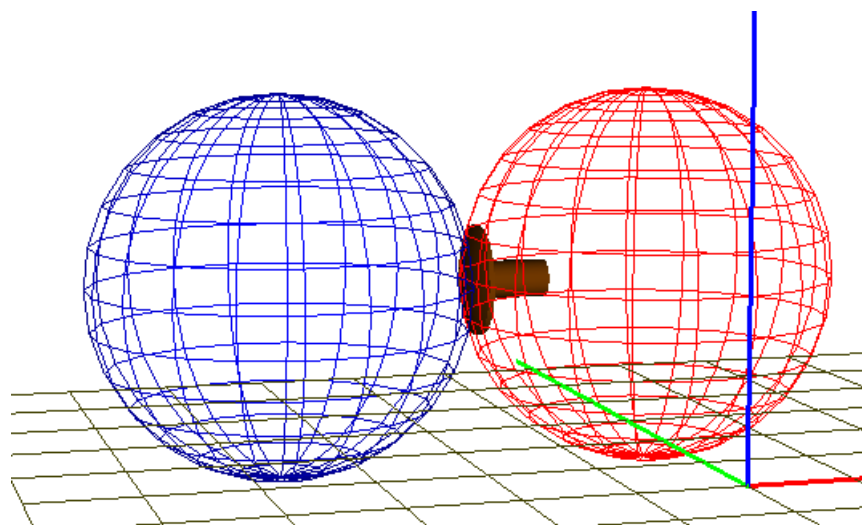

Figure 1.38. External element: contact of plates

2. Contact forces *Contact buffer RL(RR)* of the “Sphere-Sphere” type specify interaction of plates, Figure 1.38. The first body in the force element description is a plate; the second one is external, which must be assigned by creating a 3D string model. Identifiers are listed in Table 1.7.

Table 1.7

**Identifiers parameterizing plate contacts**

Name	Default value	Comments
<i>r_buffer</i>	0.7 m	Contact sphere radius
<i>c_buffer_contact</i>	1x108 N/m	Contact stiffness
<i>d_buffer_contact</i>	1x103 Ns/m	Contact damping
<i>ffr_buffer</i>	0.25	Dynamic coefficient of friction in the contact. The static coefficient of friction is 1.2 time greater than the dynamic one

**Remark.** The standard text attribute *LongitudinalForceR* is assigned to all three force elements. In such a way the program is informed that these elements are used for computation of longitudinal force in coupling system in a train formation. The total force is equal to the sum of three components.

### 1.4.3. Features of Buffer\_EXT\_F(R) models in comparison of Buffer

The *Buffer\_EXT\_F(R)* models are used for equipment of 3D models of rail vehicles by buffer coupling system in case the vehicles are included in train formations. Apart from 3D vehicles, a train model may include any number of 1D vehicles interconnected by means of simplified coupling systems. To make simulation of 3D string in the train more accurate, connection between the front or rear 3D vehicles with neighbor 1D units is realized by advanced models of the buffer coupling system described in Sect. 1.4.2. "Structure and detailed description of model Buffer", p. 1-20. Thus, the *Buffer\_EXT\_F(R)* compared to the *Buffer* model contain additional elements, in particular coupler bodies and a number of force elements which are attached automatically to neighbor 1D vehicles.

### 1.4.4. Model Buffer\_EXT\_F

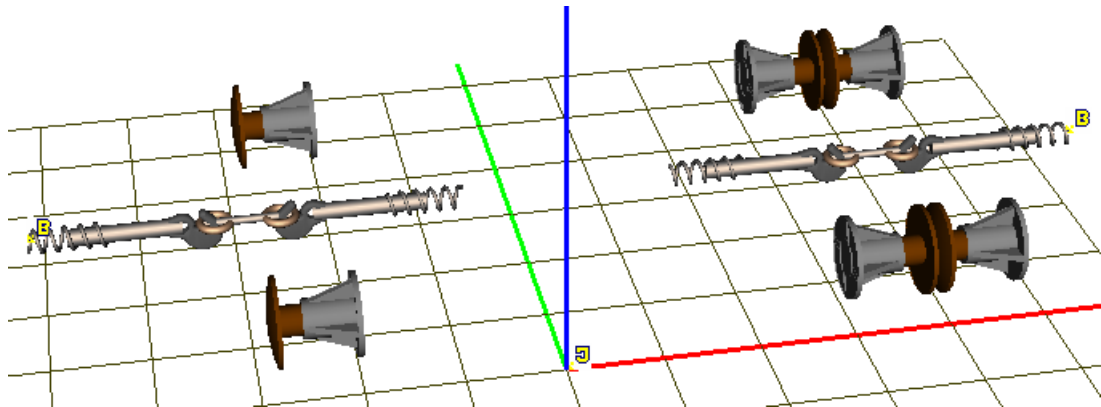

Figure 1.39. Model Buffer\_EXT\_F

The *Buffer\_EXT\_F* model is developed for equipping by coupling system the **front** vehicle of a 3D string under the assumption that it is not the first vehicle in the train. In comparison with *Buffer*, this model contains the following additional elements and modifications, see the right hand side of Figure 1.39.

- Bodies *Buffer body Ext FL (FR)* are external buffer bodies, which are connected to simplified 1D models of the neighbor vehicle in train formation.
- Bodies *Buffer plate Ext FL (FR)* are plates of external buffers.
- Joints *jBuffer body Ext FL (FR)* introduce 6 d.o.f. of each of the external buffer bodies relative to the base.
- Joints *jBuffer plate Ext FL (FR)* set translational degrees of freedom of plates relative to external buffers as well as describe draft gear models like joints *jBuffer plate RL (RR, FL, FR)* in the *Buffer* model, Sect. 1.4.2.3. "Draft gears", p. 1-22.
- External bipolar force element *Drawgear Ext F* specify the drawgear connecting the vehicle with the front 1D unit in a train.
- Contact force elements *Contact buffer Ext FL (FR)* specify interaction of plates.
- External elastic connections *Buffer body Ext FL (FR) Fixation* are special forces of the "Bushing" type fixing external buffer bodies to front 1D vehicle.

**Remark 1.** Description of these elements is similar to that of internal elements having analogous names.

**Remark 2.** It is important that the test attribute *CouplingExtFront* is assigned to the force elements *Draw gear Ext F*, *Buffer body Ext FL (FR) Fixation*. This attribute enables an automatic assignment of external second bodies to the elements as well as for computation of longitudinal forces.

### 1.4.5. Model Buffer\_EXT\_R

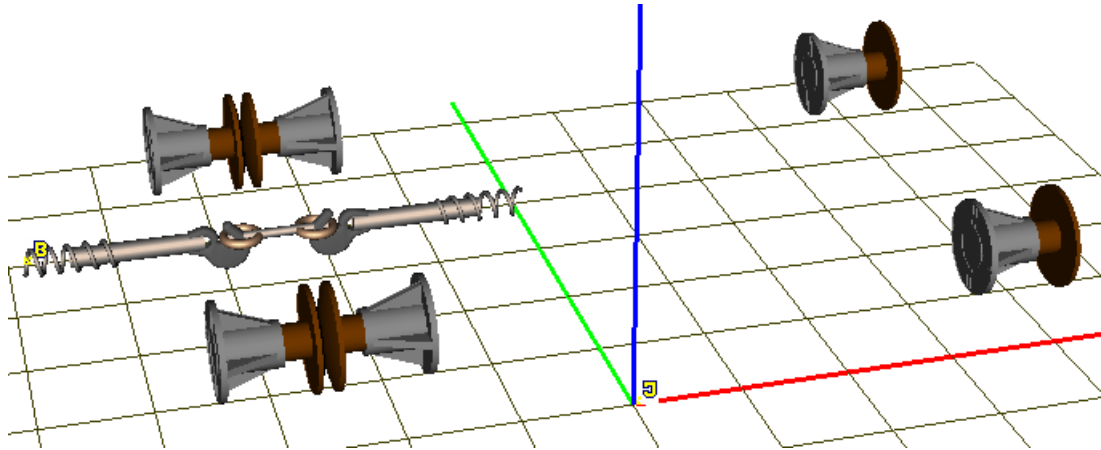

Figure 1.40. Model Buffer\_EXT\_R

The *Buffer\_EXT\_R* model is developed for equipping by coupling system the **rear** vehicle of a 3D string under the assumption that it is not the first vehicle in the train. In comparison with *Buffer*, this model contains the following additional elements and modifications, see the right hand side of Figure 1.40.

- Bodies *Buffer body Ext RL (RR)* are external buffer bodies, which are connected to simplified 1D models of the neighbor vehicle in train formation.
- Bodies *Buffer plate Ext RL (RR)* are plates of external buffers.
- Joints *jBuffer body Ext RL (RR)* introduce 6 d.o.f. of each of the external buffer bodies relative to the base.
- Joints *jBuffer plate Ext RL (RR)* set translational degrees of freedom of plates relative to external buffers as well as describe draft gear models like joints *jBuffer plate RL (RR, FL, FR)* in the *Buffer* model, Sect. 1.4.2.3. "Draft gears", p. 1-22.
- Contact force elements *Contact buffer Ext RL (RR)* specify interaction of plates.
- External elastic connections *Buffer body Ext RL (RR) Fixation* are special forces of the "Bushing" type fixing external buffer bodies to front 1D vehicle.

**Remark 1.** Description of these elements is similar to that of internal elements having analogous names.

**Remark 2.** It is important that the test attribute *CouplingExtRear* is assigned to the force elements *Draw gear Ext, Buffer body Ext RL (RR) Fixation*. This attribute enables an automatic assignment of external second bodies to the elements as well as for computation of longitudinal forces.

## 1.5. Standard identifiers and text attributes for coupling systems

The following **standard identifiers** are used in models of coupling systems:

- *CouplingBase* is the coupling base of a vehicle;
- *CouplingHeight* is the height of the coupling element over the rail head level;
- *VehicleBase* is the pivot base of a vehicle; the identifier is used in case the vehicle is included in a train formation.

Correct values of these identifiers allow the right positioning of elements from geometrical point of view.

The following standard text attributes are used to automate the process of including 3D string in a train formation.

- *CouplingExtFront* allows automating the assignment of second body, usually a car body of 1D vehicle, to external force elements. The attribute is used for force elements connecting the leading vehicle of a 3D string with the neighbor (front) 1D unit of a train formation, Sect. 1.3.4. "*Model AC\_Standard\_EXT\_F*", p. 1-15. Force elements marked with this attribute are automatically used for computation of longitudinal in-train forces in coupling system.
- *CouplingExtRear* allows automating the assignment of second body, usually a car body of 1D vehicle, to external force elements. The attribute is used for force elements connecting the trailing vehicle of a 3D string with the neighbor (rear) 1D unit of a train formation, Sect. 1.3.5. "*Model AC\_Standard\_EXT\_R*", p. 1-16. Force elements marked with this attribute are automatically used for computation of longitudinal in-train forces in coupling system.
- *LongitudinalForceR* is assigned to force elements or to a group for elements specifying the longitudinal in-train forces in the rear elements of coupling system of a vehicle. The force value is computed as a sum of projections on vehicle axis of forces marked by this attribute, Sect. 1.3.2.5. "*Interaction between two automatic couplers*", p. 1-13.

*Absence or incorrect usage of attributes follows in false results of simulation with UM Train3D module.*

## 1.6. Development of 3D string of vehicles

In this section we consider in details the process of creating 3D string models taking the automatic coupler models as coupling systems. Usage of buffer coupling system is fully analogous.

### 1.6.1. Adding automatic couplers to 3D vehicle models

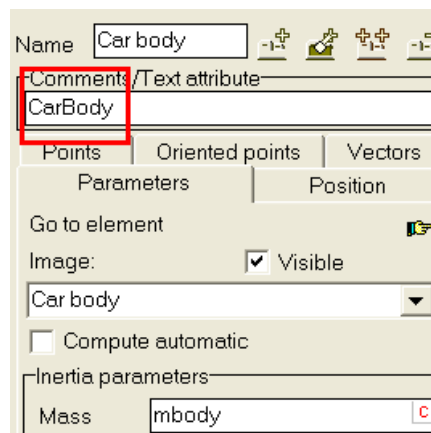

Figure 1.41. Text attribute CarBody

To add automatic coupler to 3D model of a rail vehicle with the help of **visual components**, open the vehicle model and make the following steps.

1. Verify that the *CarBody* text attribute is assigned to the vehicle car body, Figure 1.41.
2. Click on the button of visual component, Figure 1.42.



Figure 1.42. Visual components for automatic couplers (selected by box)

Initialization of values		
Identifier	Value	Comment
CouplingHeight	1.06	z coordinate of coupler over rail level
VehicleBase	8.65	Pivot base of vehicle
CouplingBase	5	Coupling base of vehicle
couplinglength	2	Length of two coupler bodies
mPlateAC	500	Mass of follower
mac	250	Mass of coupler body

Buttons: Accept, Add to the sheet: Automatic coupler

Figure 1.43. List of identifiers added to the vehicle model

3. A list of identifiers of the coupler model appears in a separate window. If the vehicle model does not contain the standard identifiers *CouplingBase* and *CouplingHeight*, their actual numeric values should be set in the identifier list in Figure 1.43. If the user wants to set the added identifiers to a special sheet of the model identifier list, he must set the name of the sheet in the “**Add to the sheet**” box of windows in Figure 1.43.

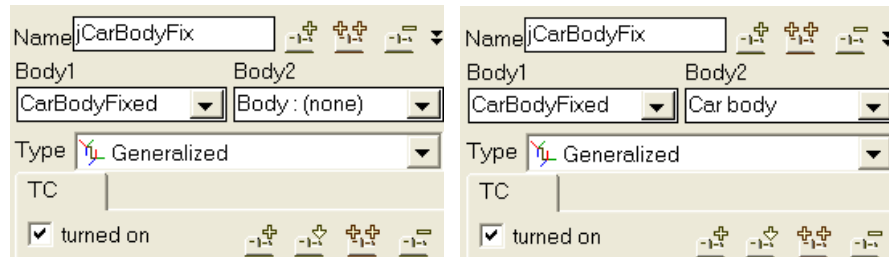

Figure 1.44. Assignment of car body as the second body in joint jCarBodyFix

4. If the user does not execute step 1, he or she must assign the car body as the second body in the joint *jCarBodyFix*, Figure 1.44.

To add automatic couplers to 3D vehicle model with the help of **UM objects**, e.g. *AC\_Standard*, *AC\_Standard\_EXT\_F*, *AC\_Standard\_EXT\_R* or their modifications, the user should execute the following steps.

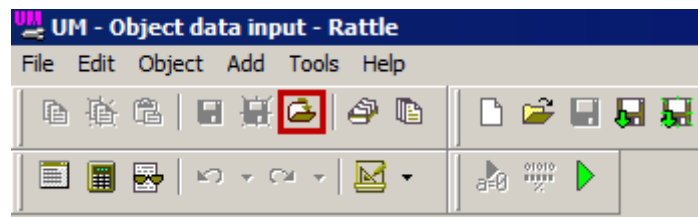



Figure 1.45. Adding coupling system as UM object

- Add a UM model of automatic coupler instead of step 2; click the  button on the tool panel of run the **Edit | Read from file...** menu command and open then input.dat file with description of the model, Figure 1.45.
- Make steps 3, 4.

### 1.6.2. Three-unit 3D string for separate using

Consider an example of development of a string of three vehicles with the help of 3D model of a freight car with tree piece bogies *simple\_18\_100*. The path to the model is [{UM Data}\Samples\Rail vehicles\simple\\_18\\_100](#). This model is intended for simulation in **UM Loco** module *without including in a train formation*. The ready model of the string *Freight-Car\_18\_100\_3Vehicles* can be found in the database, Sect. 1.2. "Database of models for Train 3D module", p. 1-4.

Note that the model already includes identifiers *CouplingBase* and *CouplingHeight*.

1. Create the model of rail car equipped with automatic couplers according to Sect. 1.3.2. "Structure of automatic coupler model AC\_Standard", p. 1-9. Save it under the name *simple\_18\_100\_AC\_Std*. Note that the database already contains the model of the freight car with automatic coupler system *simple\_18\_100\_AC\_Std*, Sect. 1.2. "Database of models for Train 3D module", p. 1-4, and the user can compare his results with this model.
2. Close the rail car model because adding of external subsystems to an UM object is impossible, if the model is open.
3. Create a new UM object by the **File | New object** menu command or by the  button on the tool panel. Save it as *FreightCar\_18\_100\_3Vehicles*.

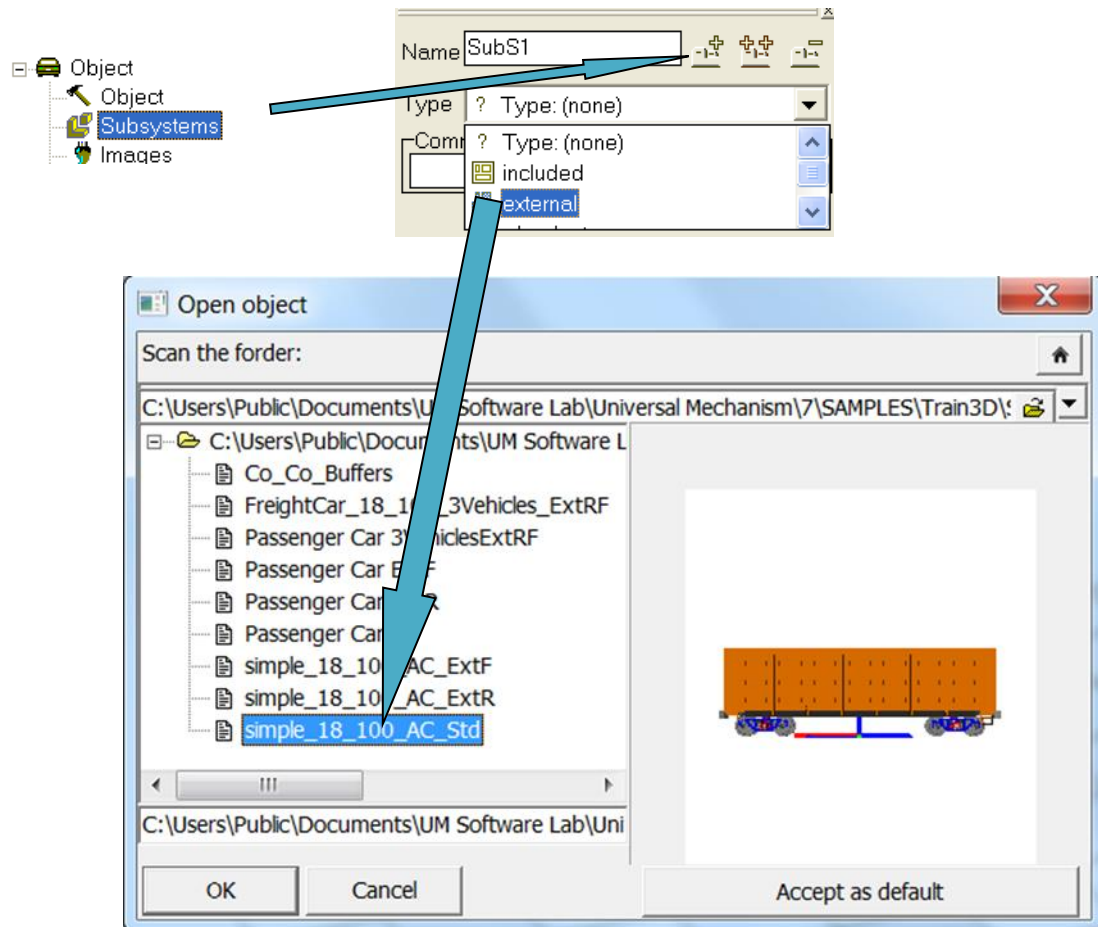

Figure 1.46. Adding external subsystem

4. Add a subsystem. Set its type as “external” and select the UM model *simple\_18\_100\_AC\_Std*, Figure 1.46.

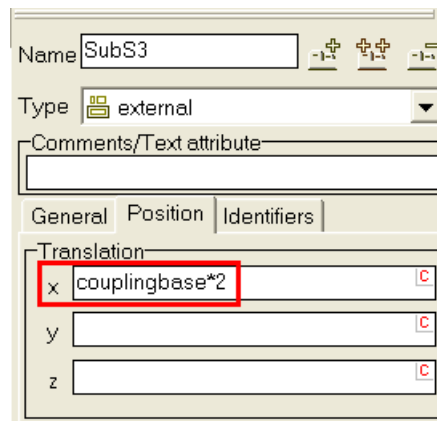

Figure 1.47. Positioning of vehicle

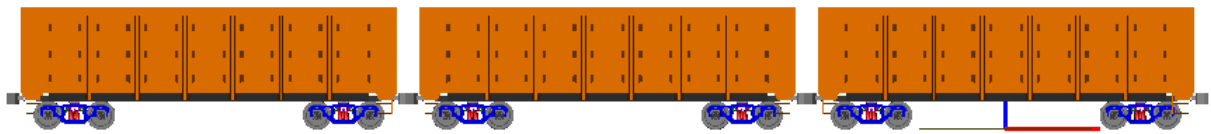



Figure 1.48. General view of 3D string

- Copy the subsystem two time by the  button and set longitudinal position of the second and third vehicles as  $-CouplingBase$  and  $-CouplingBase*2$ . Set numeric value of identifier  $CouplingBase$  equal to its value in the subsystems, Figure 1.47. The model looks like Figure 1.48.

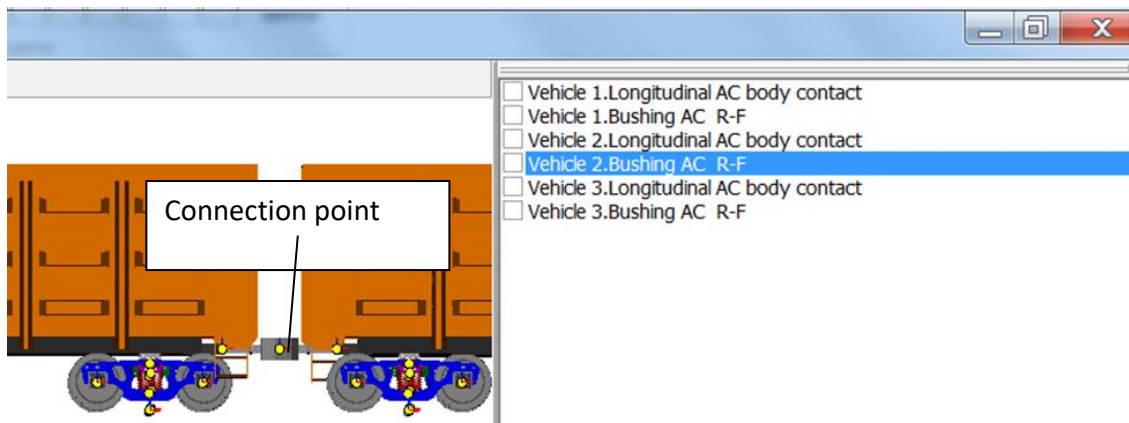

Figure 1.49. Setting connection for external elements

- The last step consists in assignment of connection points to external force elements of coupling systems. There are two such elements for each of the vehicle: *Longitudinal AC body contact* and *Bushing AC R-F* (element, specifying connections of coupler bodies). Both of these elements belong to rear part of coupling system of the vehicle. Their external bodies must be bodies of front couplers of rear neighbor vehicle.

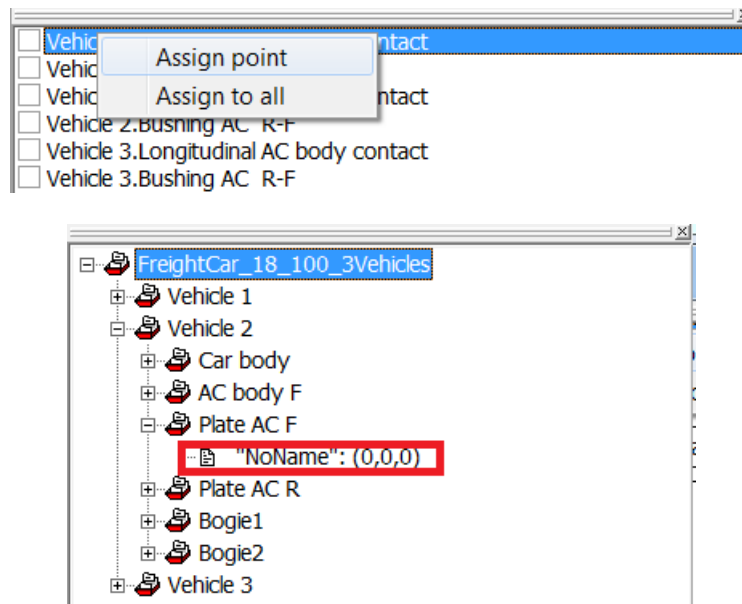

Figure 1.50. Assignment of connection point for external element

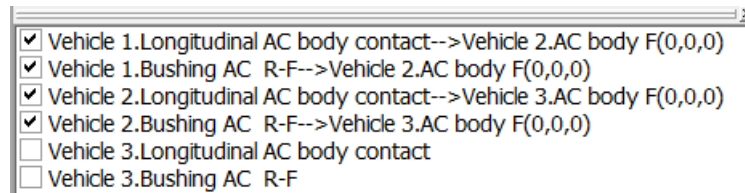

Figure 1.51. List of external elements with assigned connection (checked)

To assign a connection

- Select the **Connection** item of the object element list. The list of external elements appears in the inspection, Figure 1.49.
- Select the corresponding force element in the list, e.g. *Subs1. Longitudinal AC body contact*, and select by the mouse the connection point on the coupler body of the rear vehicle, Figure 1.49 or call the popup menu, run the **Assign point** command and select the desired connection point, Figure 1.50.

Note that connections should be assigned for 4 external elements from 6 ones in the list. Assigned elements are checked, Figure 1.51.

### 1.6.3. Three-unit 3D string for inclusion in a train model

Creation of a train connection, which can be included in a train formation generated in the **UM Train** module, is quite similar to that described in Sect. 1.6.2. *"Three-unit 3D string for separate using"*, p. 1-32. The only difference is that models *AC\_Standard\_EXT\_F* and *AC\_Standard\_EXT\_R* must be often used for the leading and trailing vehicles. However if the leading/trailing vehicle of the connection is the first/last unit in the train formation, the *AC\_Standard* must be used. Explanations are presented in Table 1.8. This method is easily applies in case of any numbers of units in a 3D string.

Table 1.8

**Vehicle models for different positions of 3D string**

Connection description	Coupler model		
	Vehicle 1	Vehicle 2	Vehicle 3
Connection outside of train	<i>AC_Standard</i>	<i>AC_Standard</i>	<i>AC_Standard</i>
Connection in head of train	<i>AC_Standard</i>	<i>AC_Standard</i>	<i>AC_Standard_EXT_R</i>
Connection in middle part of train	<i>AC_Standard_EXT_F</i>	<i>AC_Standard</i>	<i>AC_Standard_EXT_R</i>
Connection in tail of train	<i>AC_Standard_EXT_F</i>	<i>AC_Standard</i>	<i>AC_Standard</i>

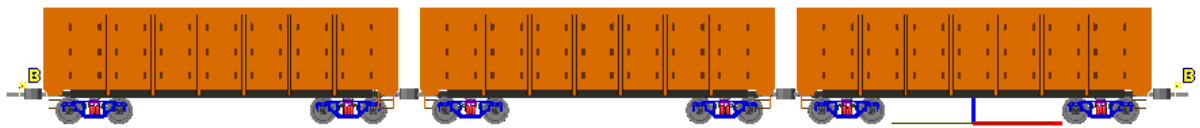

Figure 1.52. General view of 3 unit string for including in the middle part of train formation

Compare the model of 3D string for separate simulation without a train, Figure 1.48, and for including in the middle of a train formation, Figure 1.52. Names of these UM objects are *FreightCar\_18\_100\_3Vehicles* and *FreightCar\_18\_100\_3Vehicles\_ExtRF*, Sect. 1.2. "Database of models for Train 3D module", p. 1-4. The last model contains additional elements for coupling with neighbor 1D vehicles. By adding the 3D string to a train formation these couplings are assigned automatically, which in particular allows easily change positions of 3D vehicles within the train.

## 1.7. Development of train with included 3D vehicle models

### 1.7.1. General information

There are three steps in development of a train model with included 3D vehicle models.

1. Creation of 3D strings according to above instructions.
2. Development of a train model including 1D vehicle models, see [Chapter 15](#) of the user's manual.
3. Adding one or several 3D strings to the train model as external subsystems.

### 1.7.2. Example of 3D train model

Consider an example of development of a train formation including 10 1D vehicles and a 3D string.

1. Run the *UM Input* program.
2. Open the train wizard by the **Tools | Train wizard...** menu command, Figure 1.53.

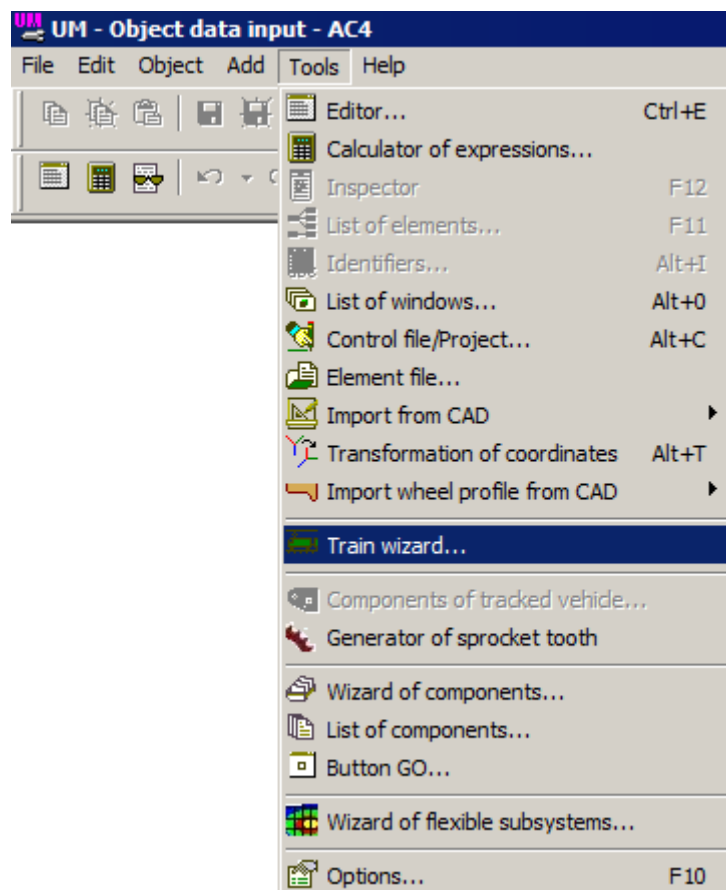

Figure 1.53. Call of train wizard

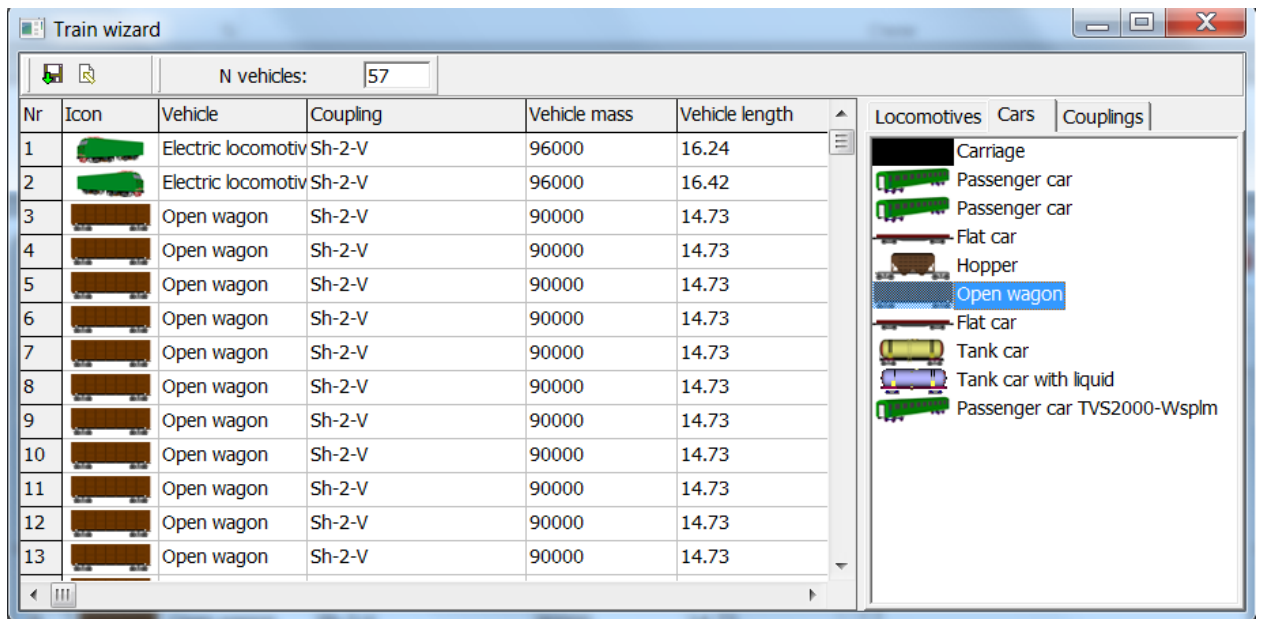

Figure 1.54. Train model with 10 1D vehicles

3. Create a train model including 10 1D vehicles, Figure 1.54.
4. Create an UM train model by clicking the button in the wizard top.

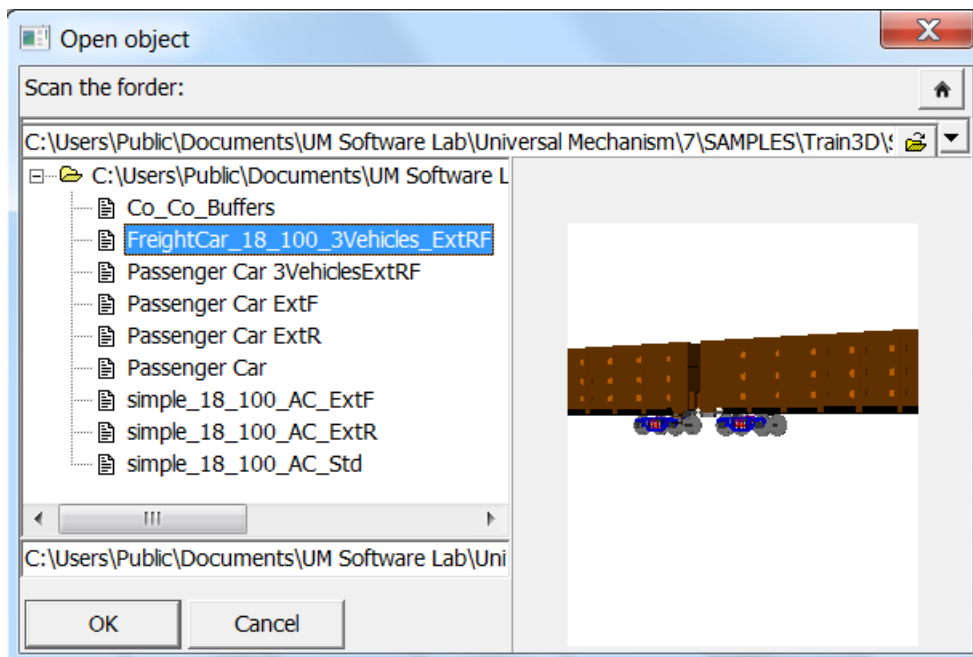
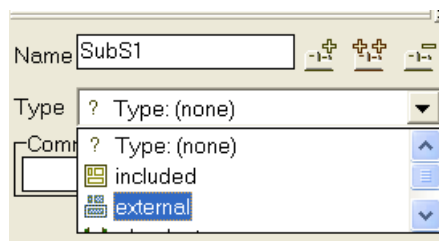



Figure 1.55. Adding external subsystem

5. Open the **Subsystems** sheet of the inspector add a subsystem by the  button, set its type “**external**”, and select the 3D string model *FreightCar\_18\_100\_3Vehicles\_ExtRF*, Figure 1.55.

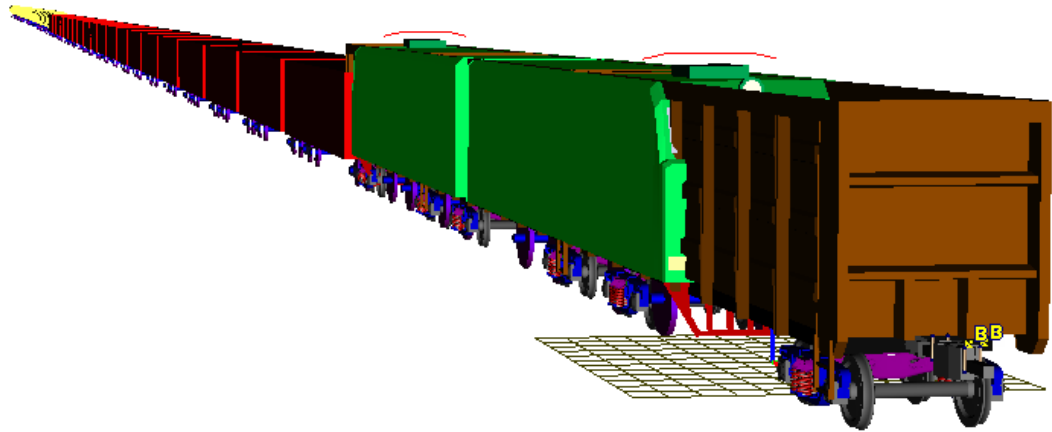

Figure 1.56. Train model with 3D vehicles

6. Do not change 3D vehicle positions in the train to their real positions. This will be done in the simulation program **UM Simulation** automatically. So far, the train model looks not correct from the point of view of vehicle positions, Figure 1.56. Nevertheless, it is ready for simulation, and the simulation module can be started.

## 1.8. Simulation of train with included 3D vehicles

By simulation of a train including both 1D and 3D vehicle models, all tools realized in **UM Loco** ([Chapter 8](#)) and **UM Train** ([Chapter 15](#)) are available. Here we consider some features of simulation in **UM Train3D** module. We will use the train model developed according to instructions of the previous section.

### 1.8.1. Positions of 3D vehicles in the train

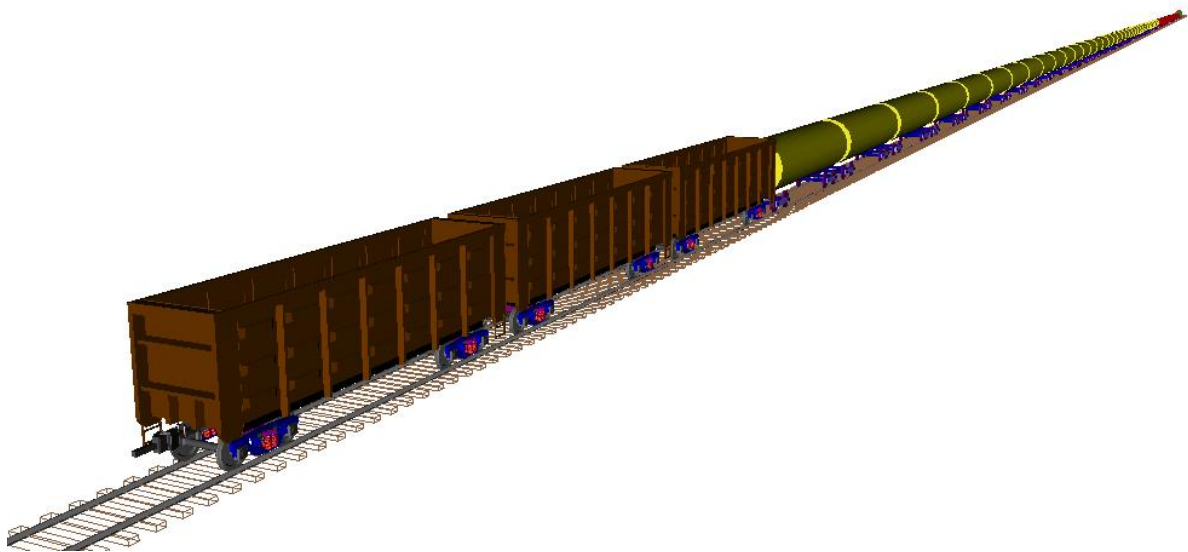

Figure 1.57. 3D string in the tail of the train

If the train model is opened for the first time in the simulation program **UM Simulation**, the 3D vehicles are located automatically in the tailing part of the train Figure 1.57. Note, that this position is not quite correct for simulation in our case because the 3D connection was created for simulation in the middle part of the train.

To change positions of 3D vehicle models, open the **Train | Options | Vehicle positions** tab in the object simulation inspector. Sequential numbers should be set for vehicles in a string, e.g. 5,6,7, Figure 1.58. Press *Enter* after setting position of all the vehicles.

*Simulation will be incorrect* if the connection is broken due to non-sequential numbering of 3D vehicle in the such as 5,8,9.

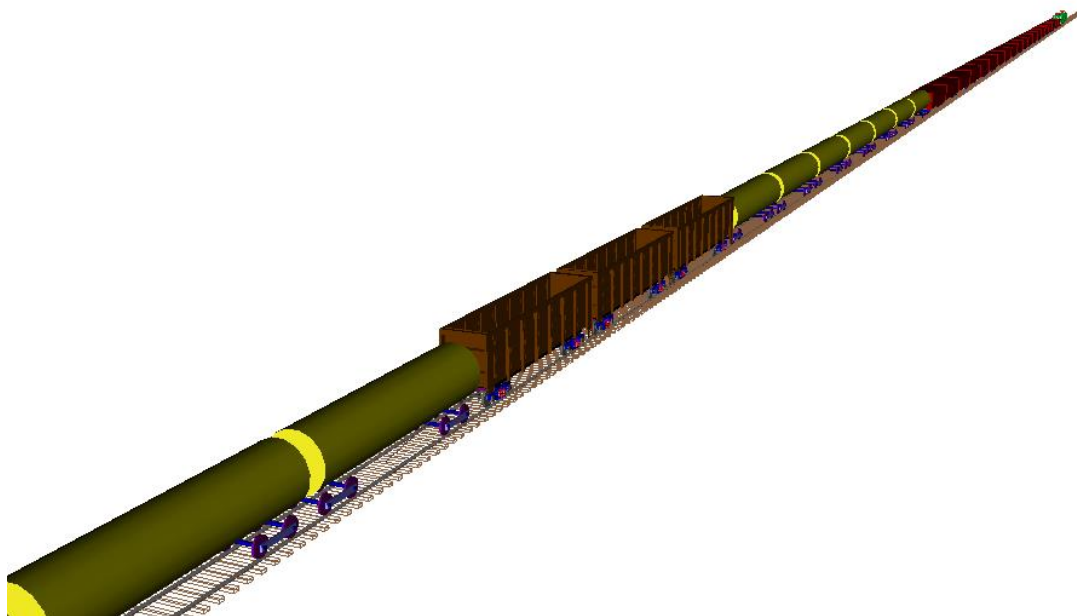
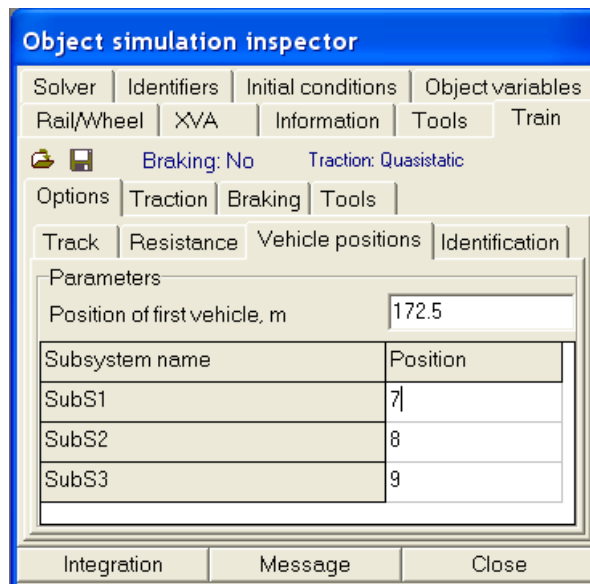

Figure 1.58. Positioning of 3D vehicles

### 1.8.2. Specifying track macrogeometry

Track macrogeometry must be specified with the tool realized in the **UM Train** module. A macrogeometry file \*.mcg is assigned in the **Train | Options | Track** tab of the inspector. Thus, the **Wheel/Rail | Track | Macrogeometry** tab of **UM Loco** module is not available with train 3D models.

### 1.8.3. Positioning of the first vehicle of train

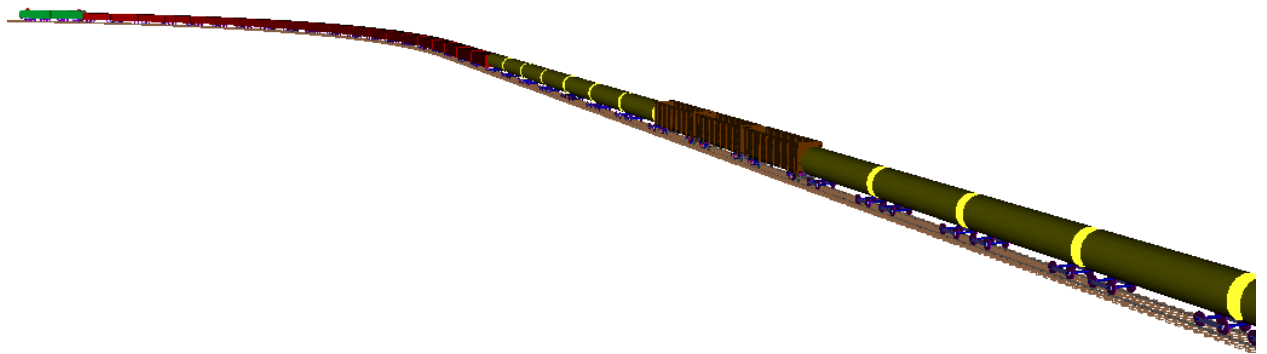
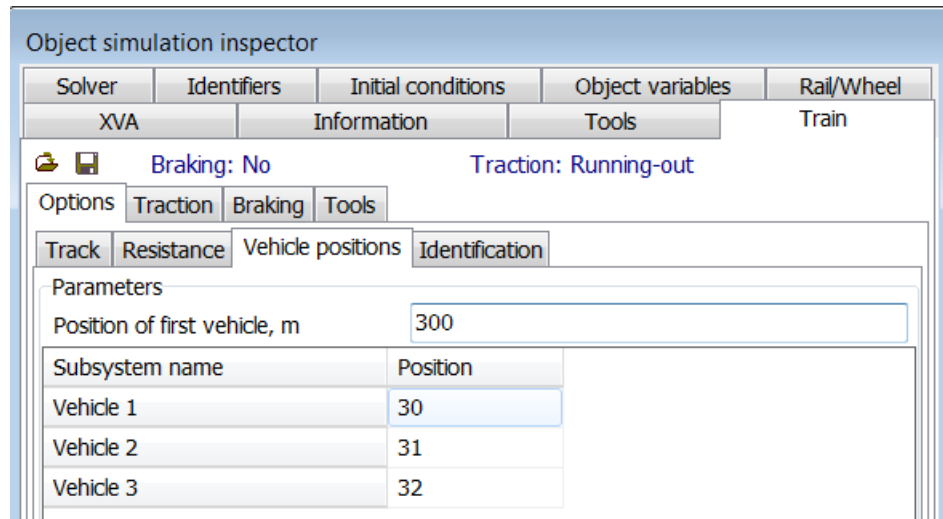

Figure 1.59. Initial shift of train

Simulation process for a 3D train is much slower in comparison with 1D trains. To reduce the duration time the user can shift the train in initial position by setting the position of the first vehicle, Figure 1.58, so that the first 3D vehicle will be located right before the curve, Figure 1.59. It is recommended to enter a big enough number in the box “Position of the first vehicle”. The program computes the position of the first vehicle in the train so that the leading 3D vehicle is located in the beginning of the curve. For example, if the position 300 m is set for the train in the figure, the program sets the value 172.5 m.

## 1.9. Development of train model including 3D vehicles only

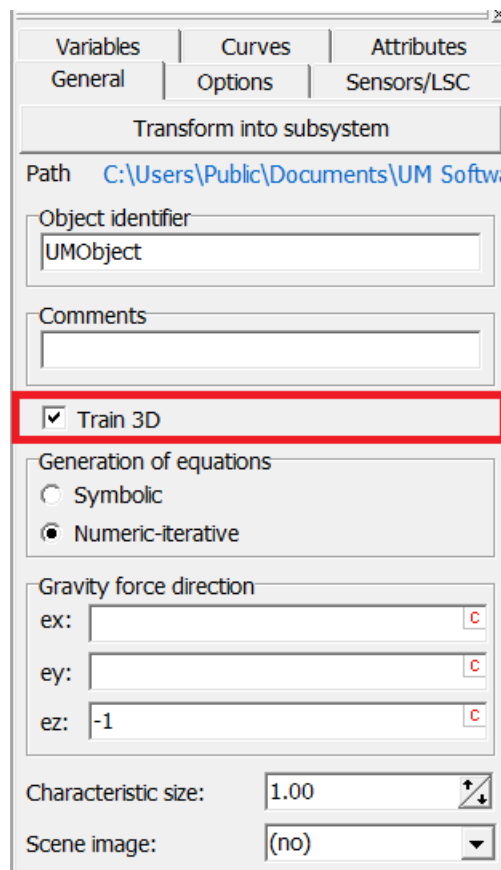

Figure 1.60. Option Train 3D

It is possible in UM to create train models, which include 3D rail vehicles only and no 1D vehicles. For this purpose the user develops a 3D string as it is described above. The connection must include **at least 4 vehicles**. Each of the vehicles must be an **external subsystem**. As a result, the **Train 3D** option will be available on the **Object | General tab** of the inspector in the **UM Input** program, Figure 1.60. Checking the option converts the model to the Train 3D model, i.e., all procedures of the train longitudinal dynamics analysis become available along with the conventional rail vehicle dynamics, in particular the braking process.

The database of models includes the models *Passenger train 3D*, which contains 3D models of vehicles only, Sect. 1.2. "Database of models for Train 3D module", p. 1-4, Figure 1.61.

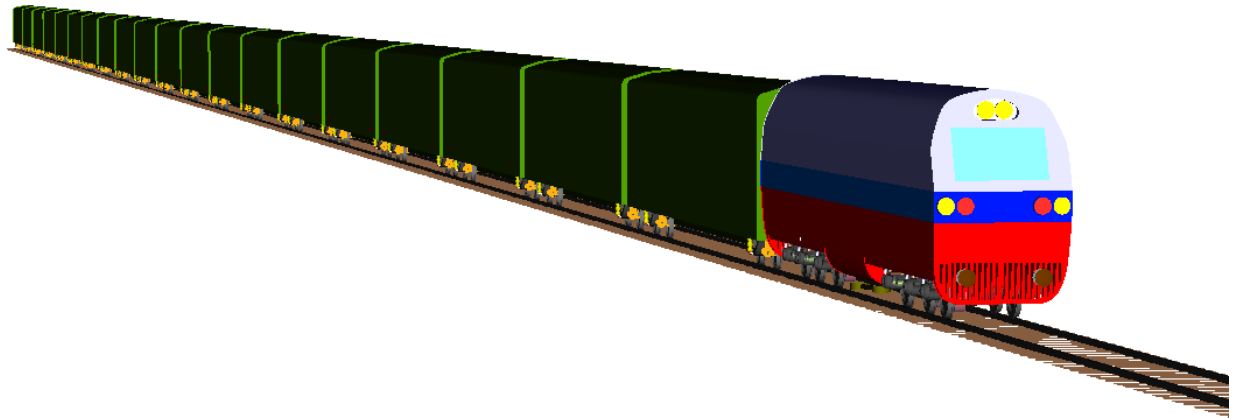

Figure 1.61. Model of passenger train including 3D vehicles only