

Simulation of Tracked Vehicle Dynamics

Tools and methods for simulation of tracked vehicle dynamics with Universal Mechanism software are considered

Contents

18. SIMULATION OF TRACKED VEHICLE DYNAMICS	1-4
18.1. DEVELOPMENT OF TV MODELS IN UM INPUT PROGRAM	1-6
18.1.1. Standard elements of tracked suspension.....	1-6
18.1.1.1. Specification of elements and their models	1-6
18.1.1.2. Main system of coordinates	1-8
18.1.1.3. Local systems of coordinates for wheels and rollers	1-8
18.1.1.4. Description of standard components.....	1-9
18.1.1.4.1. Suspension.....	1-9
18.1.1.4.1.1. Standard elements and identifiers of suspension subsystems.....	1-10
18.1.1.4.1.2. Selected identifiers of suspension subsystems	1-13
18.1.1.4.1.3. Torsion bar suspension.....	1-15
18.1.1.4.1.4. Suspension bogie with two wheels and two arms	1-23
18.1.1.4.1.5. Torsion two-wheel bogie.....	1-27
18.1.1.4.1.6. Road wheel for fixed suspension	1-30
18.1.1.4.2. Idler and tension device.....	1-31
18.1.1.4.2.1. Idler on a crank. A simplified model.....	1-33
18.1.1.4.2.2. Idler on a crank. A more detailed model	1-41
18.1.1.4.3. Sprocket.....	1-43
18.1.1.4.3.1. Geometrical parameters of sprocket.....	1-43
18.1.1.4.3.2. Automatic generator of sprocket tooth profiles	1-45
18.1.1.4.3.3. Creation of profile by curve editor	1-48
18.1.1.4.3.4. Template of sprocket.....	1-51
18.1.1.4.4. Track link	1-53
18.1.1.4.4.1. Track link with rigid joint	1-55
18.1.1.4.4.2. Track link with flexible joint (bushing)	1-57
18.1.1.4.4.3. Track link with two parallel bushings (double pin).....	1-59
18.1.1.4.5. Roller.....	1-60
18.1.2. Development of user's components	1-62
18.1.2.1. Development of a torsion bogie with three wheels	1-62
18.1.3. Registration of new TV components.....	1-66
18.1.4. Development of TV model	1-68
18.1.4.1. Preparing step	1-69
18.1.4.2. Adding a track subsystem	1-69
18.1.4.3. Track structure	1-70
18.1.4.4. Suspension	1-72
18.1.4.5. Sprocket	1-73
18.1.4.6. Idler.....	1-74
18.1.4.7. Rollers.....	1-75
18.1.4.8. Track.....	1-76
18.1.4.9. Completion of track model. Adding dampers	1-77
18.1.5. Finalization of TV model.....	1-80
18.1.5.1. Adding a hull	1-80
18.1.5.2. Connection of track with hull	1-82
18.1.5.3. Adding the second track	1-83
18.1.5.4. Correction of vertical TV position	1-85
18.1.6. Transmission and steering system.....	1-86
18.1.6.1. Adding transmission from database.....	1-86
18.1.6.2. Common element of standard transmission models.....	1-87
18.1.6.2.1. Fictitious body.....	1-88
18.1.6.2.2. Internal combustion engine	1-89
18.1.6.2.3. Main clutch, torque converter.....	1-90
18.1.6.2.4. Gearbox	1-91
18.1.6.2.5. Stopping brake.....	1-92
18.1.6.2.6. Final drive.....	1-92
18.1.6.2.7. Identifiers.....	1-93
18.1.6.2.8. Steps after adding transmission model	1-94
18.1.6.3. Clutch-Brake steering system	1-96
18.1.6.4. Planetary gear steering system.....	1-98

18.1.6.5. Controlled differential steering system	1-100
18.1.6.6. "Maybach" double differential steering system	1-102
18.1.6.7. Double differential steering system	1-104
18.1.6.8. Double differential steering system (SU).....	1-106
18.1.6.9. Triple differential steering system	1-108
18.1.6.10. Double differential steering system with hydrostatic drive (HSD).....	1-109
18.2. SIMULATION OF TV DYNAMICS	1-111
18.2.1. Models of force interactions	1-111
18.2.1.1. Sprocket-pin interaction.....	1-111
18.2.1.2. Track-ground interaction	1-112
18.2.1.2.1. Ground model without sinkage.....	1-113
18.2.1.2.2. Bekker ground model	1-113
18.2.1.3. Rolling of wheel on track chain	1-116
18.2.1.4. Normal forces in wheel-track interaction.....	1-116
18.2.1.5. Restrictive force and moment	1-119
18.2.1.6. Force for hull locking in horizontal plane.....	1-119
18.2.1.7. Evaluation of stiffness constant in wheel-track contacts	1-120
18.2.2. Controlled motion of TV.....	1-121
18.2.2.1. General information about controlled motion of TV	1-121
18.2.2.2. Driver model.....	1-122
18.2.2.3. Geometry of controlled motion of TV	1-123
18.2.2.3.1. Straight motion	1-123
18.2.2.3.2. Plane curve	1-123
18.2.2.3.3. Testing area	1-124
18.2.3. Classification of dynamic tests.....	1-126
18.2.4. Preparing TV for simulation	1-126
18.2.4.1. Options tab.....	1-128
18.2.4.1.1. General options.....	1-128
18.2.4.1.2. Irregularities	1-129
18.2.4.1.2.1. File with irregularities	1-129
18.2.4.1.2.2. Harmonic irregularities	1-130
18.2.4.1.2.3. Smooth run on irregularities by start.....	1-130
18.2.4.1.2.4. Examples of irregularities	1-130
18.2.4.1.2.5. Visualization of road	1-131
18.2.4.1.3. Parameters of macrogeometry	1-133
18.2.4.1.3.1. Routes on testing area	1-133
18.2.4.1.3.2. Parameters of the road image	1-138
18.2.4.2. Resistance tab	1-139
18.2.4.3. Tools tab: setting speed history.....	1-140
18.2.4.4. Identification tab.....	1-141
18.2.4.4.1. Track contact parameters.....	1-142
18.2.4.4.2. Hull locking parameters.....	1-143
18.2.4.4.3. Traction torques.....	1-144
18.2.4.4.4. Terrain parameters.....	1-145
18.2.4.5. Tests tab	1-146
18.2.4.5.1. Test: Equilibrium.....	1-147
18.2.4.5.2. Test: track tension.....	1-150
18.2.4.5.3. Test: tension by preload.....	1-155
18.2.4.5.4. Test: Vertical harmonic loading	1-160
18.2.4.5.5. Test: Computation of initial velocities	1-162
18.2.4.5.6. Tests with longitudinal motion of TV	1-164
18.2.4.5.6.1. Test: straight motion	1-166
18.2.4.5.6.2. Test: open loop steering	1-167
18.2.4.5.6.3. Test with driver	1-168
18.2.5. Solver	1-170
18.2.6. List of special variables for tracked vehicles	1-171
18.2.7. Features of multivariant calculations with TV	1-173
18.2.7.1. Use of standard internal identifiers	1-173
18.2.7.2. Finish conditions of experiments by distance	1-175
18.3. REFERENCES	1-177

1. Simulation of tracked vehicle dynamics

UM Tracked Vehicle module has been developed for an automatic generation of models of tracked vehicles (TV) and analysis of their dynamics.

In the current UM version, the following tools are available in **UM Tracked Vehicle**.

- Automatic generation of tracks with the help of library of basic track components.
- Expansion of the library by the user's components.
- Dynamic analysis of tracked vehicle using standard dynamic tests.

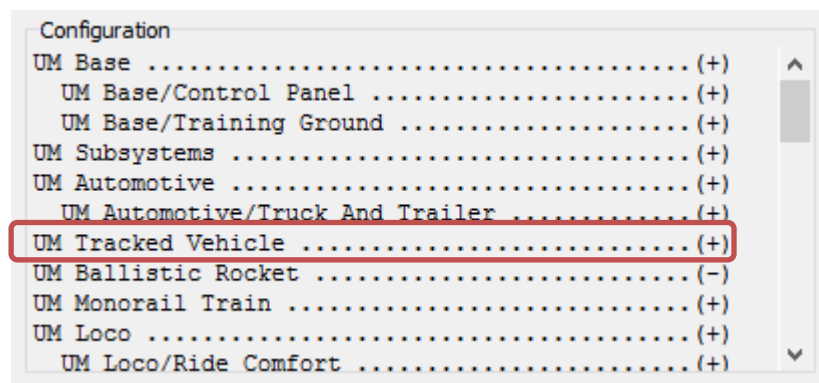

Figure 1.1. List of UM modules

To verify, whether the current UM version includes the module of simulation of TV, run the **UM Input** program and call the **About** window by the **Help | About...** menu command. The module **UM Tracked Vehicle** is available if it is marked by the (+) sign, Figure 1.1.



Figure 1.2. Model of a TV

Standard model of a TV includes (Figure 1.2)

- hull,
- two tracks,
- elements of transmission,

- additional mechanisms tools and manipulators, if necessary.

Development of a track model is automated to a considerable degree. If necessary, a detailed modeling a transmission by the user is possible with standard UM elements.

In the current UM version, several types of TV suspensions can be modeled: fixed, bogies, torsion-bar suspension etc.

We recommend to start studying the UM Tracked Vehicle module with the file [gs UM Caterpillar.pdf](#).

It is recommended also to look at TV models, which are included in UM Tracked Vehicle standard configuration:

[{UM Data}\SAMPLES\Tracked_Vehicles\gsTV;](#)

[{UM Data}\SAMPLES\Tracked_Vehicles\M1A1;](#)

[{UM Data}\SAMPLES\Tracked_Vehicles\FH200.](#)

1.1. Development of TV models in UM Input program

1.1.1. Standard elements of tracked suspension

1.1.1.1. Specification of elements and their models

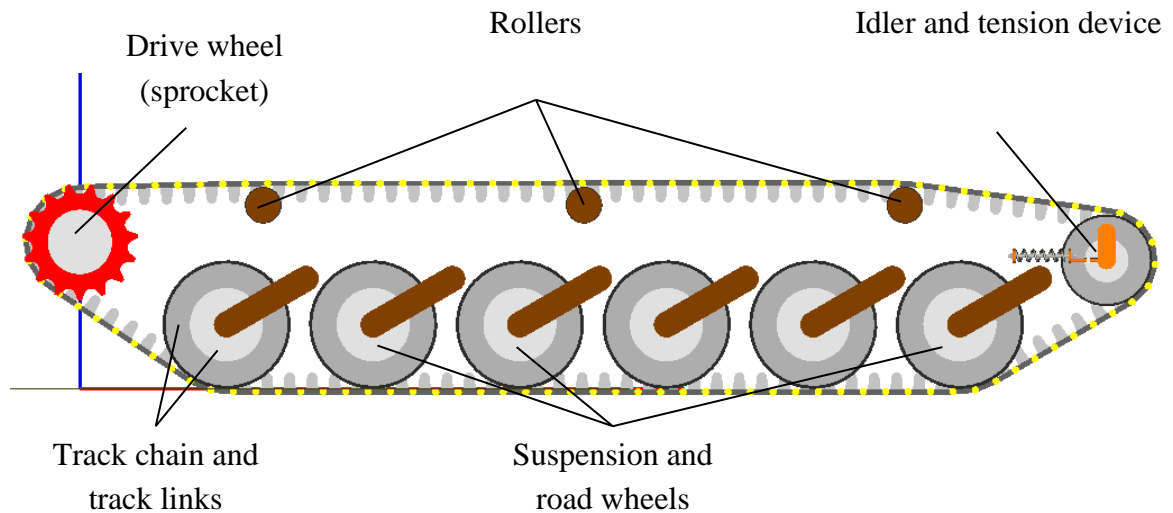

Figure 1.3. Example of a tracked suspension

An example of tracked suspension (a torsion bar suspension) is shown in Figure 1.3. The main elements of the track model are

- suspension with *road wheels*;
- *sprocket*;
- *track chain* consisting of a number of rigid *track links*, connected by *rigid*, *flexible* or *parallel* joints;
- *idler* with a tension mechanism;
- *rollers*.

To automate the process of development of a track model, a set of standard or user's created components are used, as well as a special tool for description of a track in the Input module.

The standard components are located in text files in the directory **{UM Data}\Caterpillar\Subsystems**.

Here is the list of the standard components.

1. Suspensions:

- *torsion_bar_wheel.dat* is a unit of the torsion bar suspension, which includes one road wheel and torsion bar;
- *bogie_joint.dat* is a suspension bogie with two road wheels connected to the hull by a revolute joint;
- *bogie_torsion.dat* is a suspension bogie with two road wheels connected to the hull by a torsion bar.

2. Sprocket: *sprocket.dat*.

3. Idler with a tension device:

- *idler_crank_simple.dat* is a simplified model of an idler on a crank;
- *idler_crank.dat* is a more detailed model of an idler on a crank;
- *idler_slider.dat* is a model of an idler on a slider.

4. A track link

- *track_link_rigid.dat* is a track link with a rigid joint;
- *track_link_bushing.dat* is a track link with a flexible joint (bushing);
- *track_link_parallel.dat* is a track with two flexible (parallel) joints (bushings).

5. A roller: roller.dat.

Using the components as well as geometric data, UM automatically generates track models.

1.1.1.2. Main system of coordinates

The standard system of coordinates in **UM Tracked Vehicle** coincides with inertial frame SC0. Their axes have the following directions:

- X-axis is directed forward along the axis of symmetry of TV in its initial position;
- Z-axis is directed vertically upward;
- Y-axis is directed to the left from the forward motion.

As a rule, the rotation axis of a sprocket (rear drive TV) or an idler (front drive TV) is located in YZ plane of SC0 with zero value of longitudinal coordinate, Figure 1.3, so that X coordinates of other wheels and rollers are positive.

1.1.1.3. Local systems of coordinates for wheels and rollers

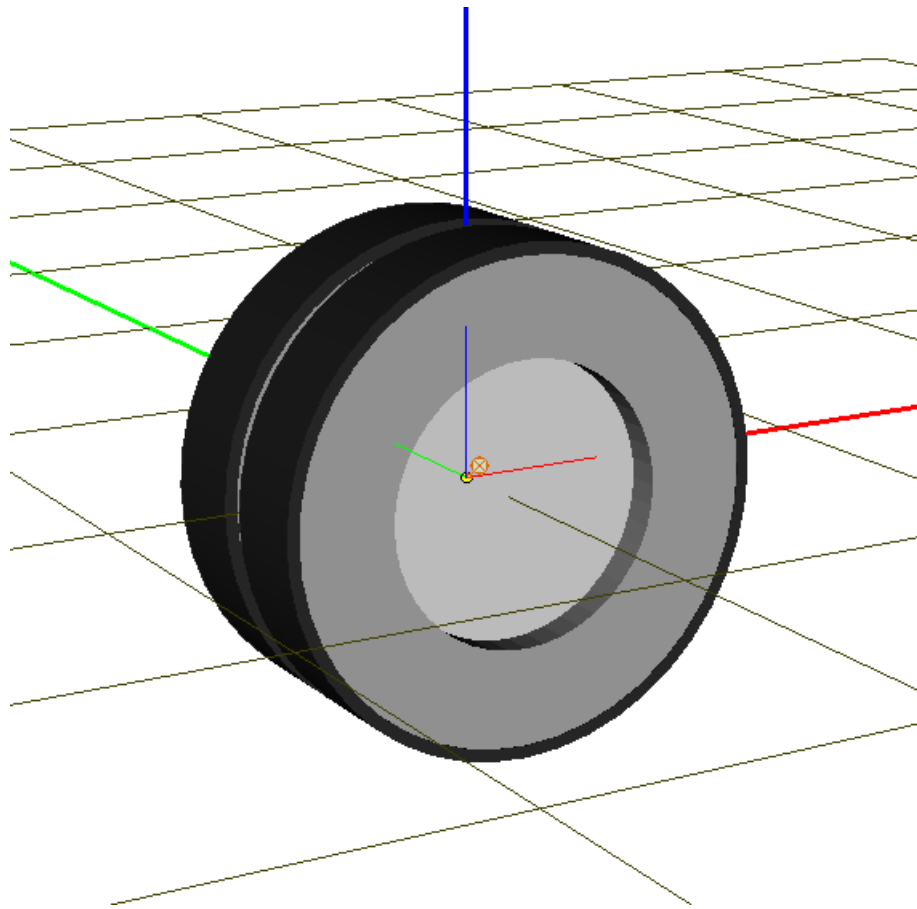

Figure 1.4. LSC for road wheel

Local systems of coordinates (LSC) for bodies, which model road wheels, idler, sprocket and rollers, meet some requirement. Origins of this SC must be located in the centers of the wheels, Figure 1.4. In particular, rotation axis of wheels must pass through the origins of LSC. All standard components satisfy this claim. The user should remember it when developing its own components, Section 1.1.3 *Registration of new TV components*.

1.1.1.4. Description of standard components

1.1.1.4.1. Suspension

Elements of suspension are developed as included subsystems.

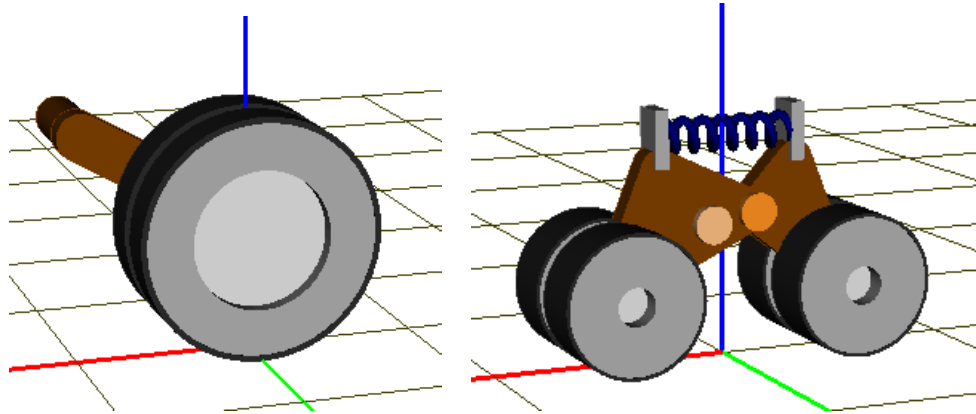

Figure 1.5. Examples of subsystems describing elements of suspension. Torsion bar and joint bogie suspensions

Each unit of the subsystem contains one (individual suspensions) or several (bogies) road wheels, Figure 1.5.

If necessary, a subsystem might contain a full description of track suspension and all road wheels.

1.1.1.4.1.1. Standard elements and identifiers of suspension subsystems

A correct description of suspension unit requires use of standard elements.

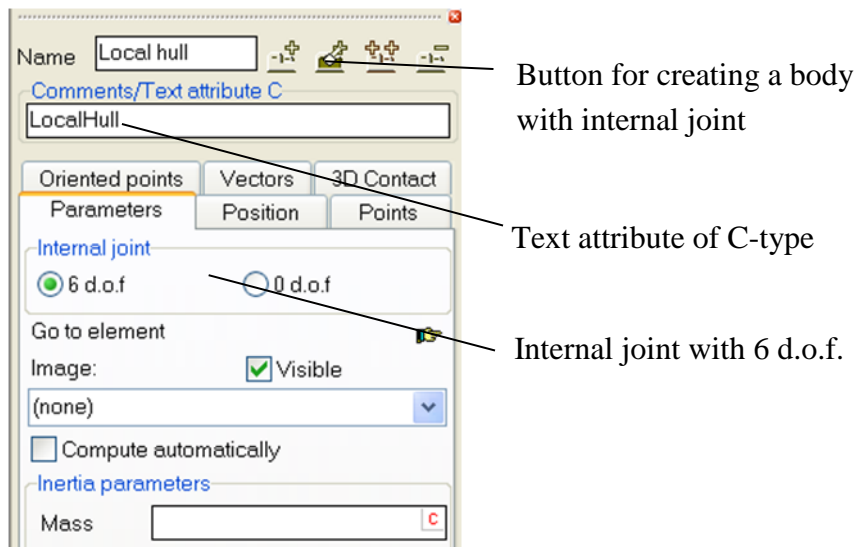

Figure 1.6. Body ‘Local hull’

1. Standard element ‘Local hull’.

A *local hull* is a massless body with 6 degrees of freedom (d.o.f.) marked with the text attribute of C-type: *LocalHull*, Figure 1.6.

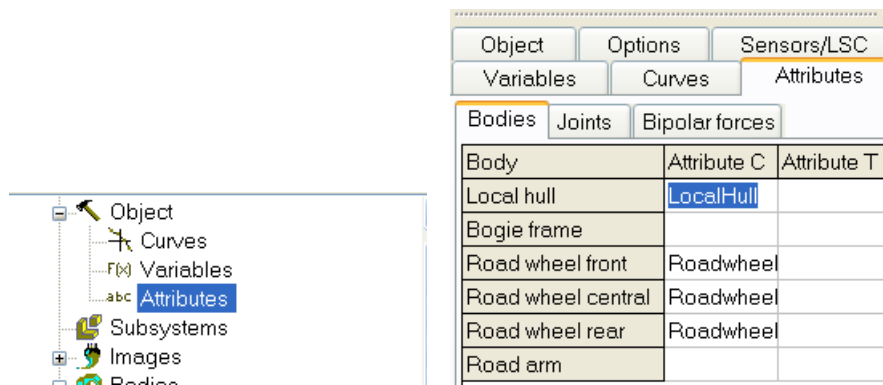

Figure 1.7. Text attributes of C and T types

Remark. There exist in UM two types of text attributes, which are used for internal identification of some elements, in particular, bodies. They are named attributes of C-type and T-type. The attribute of C-type can be assigned in the **Comments/Text attribute C** box, Figure 1.6. Both attributes are available on the Object | Attributes tab of the inspector, Figure 1.7.

The body *Local hull* is used by description of joints and force elements connecting bodies of the suspension with the hull of TV. The hull is not included in the suspension unit, and joints and force elements are connected with the local hull. By automatic development of a track model, the local hull of the subsystem unit is rigidly connected by UM with the analogous local hull of the

track, and the internal joint with 6 d.o.f. is ignored. After that the local hull of the track is rigidly connected with the hull of TV, and, in fact, elements of suspension are attached to the real hull of TV.

While creating a body *Local hull*, the  button must be used to generate a body with an internal joint, Figure 1.6.

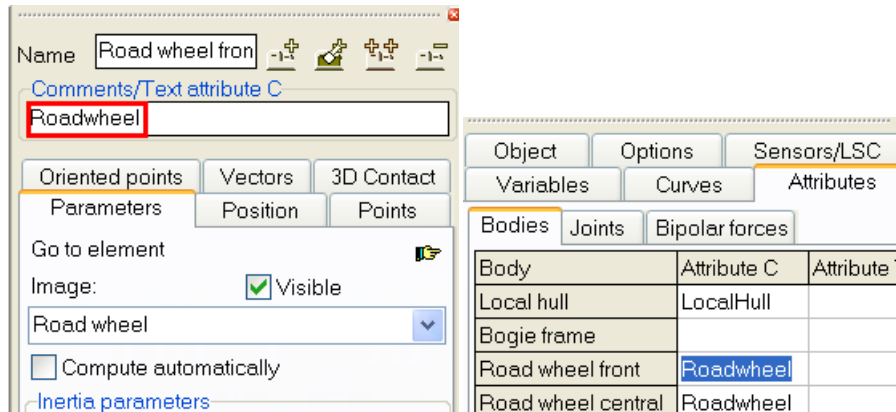

Figure 1.8. Text attributes on the Bodies and Object | Attributes | Bodies tabs

Standard element: text attribute of a road wheel *RoadWheel*.

Bodies modeling road wheels must be marked by the text attribute of C-type *RoadWheel*, Figure 1.8.

Standard elements: standard identifiers, Table 1.1, Figure 1.9.

Table 1.1

Identifier	Comments
<i>xbogie</i>	Position of subsystem relative to SC0 in longitudinal direction
<i>rroadwheel</i>	Radius of road wheel
<i>wroadwheel</i>	Width of road wheel
<i>side_key</i>	Indicator of a left (1) or right (-1) track. This identifier should be used for specifying lateral coordinates, which have different signs for the left and right tracks
<i>wguide</i>	Width of a slot in the wheel for run of track teeth
<i>hguide</i>	Depth of a slot in the wheel for run of track teeth
<i>guide_in_key</i>	Indicator of existence (1) or absence (0) of the slot for run of track teeth

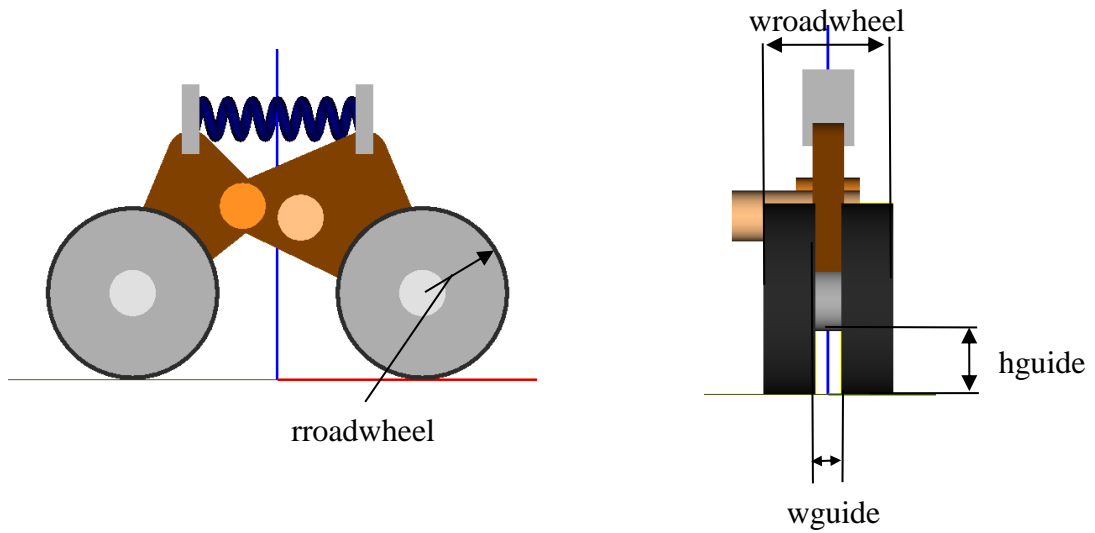

Figure 1.9. Standard geometrical identifiers

Remark. Geometrically, models of suspension units are developed in such a way that by *side_key=1* the geometry corresponds to the left track, whereas by *side_key=-1* to the right one. With this purpose, the identifier is used as a multiplier for geometrical parameters having different signs for the left and right tracks.
 Example: $-y_{road_arm_joint} * side_key$

1.1.1.4.1.2. Selected identifiers of suspension subsystems

To get access to the most important geometrical parameters of suspension unit by generation of a track, it is recommended to create a list of *selected identifiers*, which parameterize necessary parameters in the suspension. List of selected identifiers denotes a set of identifiers of the owner object (an object that owns the subsystem), which names coincide with the names of corresponding identifiers of the subsystem.

Models of the standard suspension units contain ready lists of selected identifiers, which can be modified by the user.

To create and modify the list of selected identifiers, the following steps are necessary.

1. Create a new object in **UM Input**.
2. Read a component by the  button or by the **Edit | Read from file...** menu command.

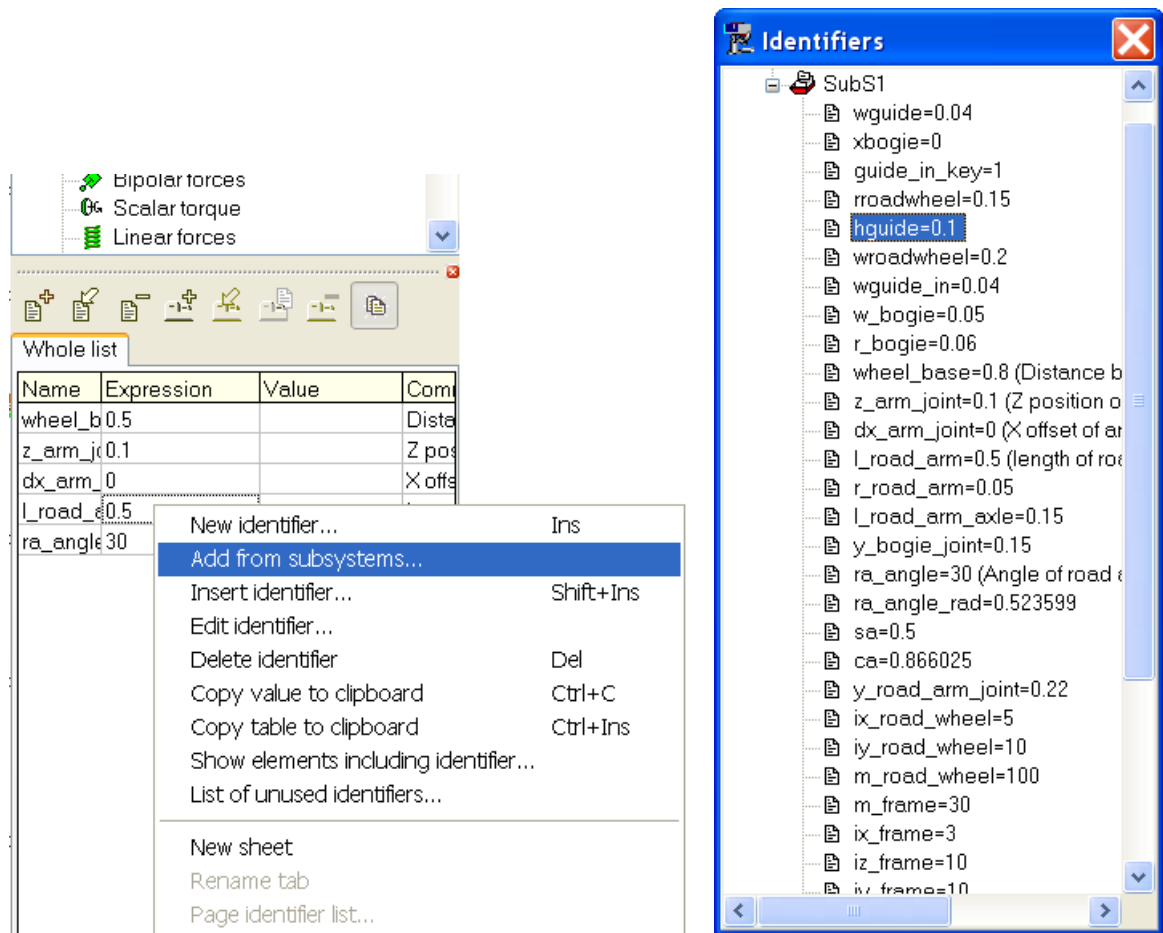



Figure 1.10. Adding selected identifiers from subsystem

3. To add new identifiers to the list of selected identifiers, click the right mouse button on the list and then click the **Add from subsystems** menu item (Figure 1.10, left).
4. Add necessary identifiers by clicking on the corresponding elements of the appeared list, Figure 1.10, right.
5. Save the modified component by the  button on the tool panel or by the **File | Save as component...** menu command.

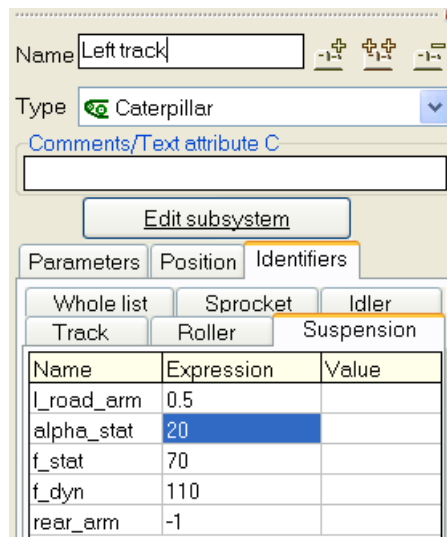

Figure 1.11. List of selected identifiers of torsion bar suspension in the wizard of track

After adding a suspension unit to the track model, the selected identifiers become available for modification their numeric values on **the Identifiers | Suspension** tab, Figure 1.11.

1.1.1.4.1.3. Torsion bar suspension

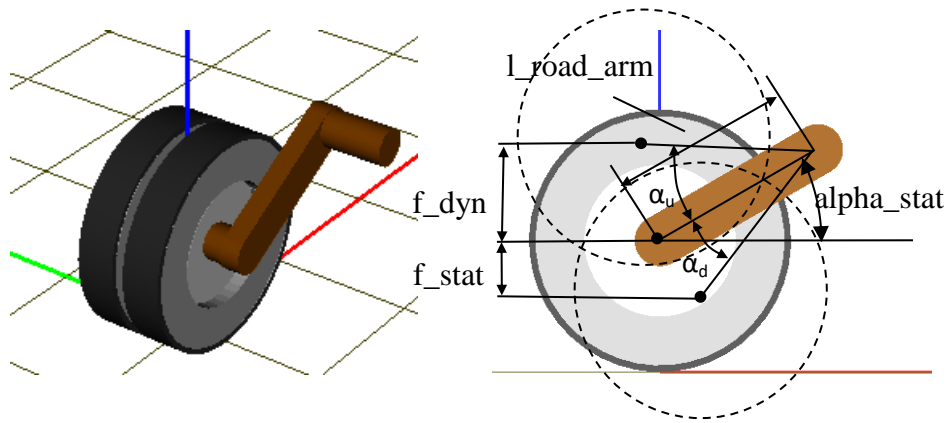

Figure 1.12. Torsion bar suspension and selected identifiers

This suspension unit models the most frequently used torsion bar suspension.

1. **Path to the component file:** {UM Data}\Caterpillar\Subsystems\torsion_bar_wheel.dat.
2. **Selected identifiers,** Table 1.2, Figure 1.12.

Table 1.2

Identifier	Default value	Comments
l_road_arm	0.5	(m) length of torsion arm
alpha_stat	20	(degrees) Angle of the arm in-clination to the horizon by static position of TV
f_stat	70	(mm) Static vertical travel of wheel
f_dyn	120	(mm) Maximal dynamic vertical travel of wheel
p_stat	7000	(N) Static load for a wheel
rear_arm	1	(±1) Key for direction of the torsion axis relative to the wheel: rear (1) or front (-1)

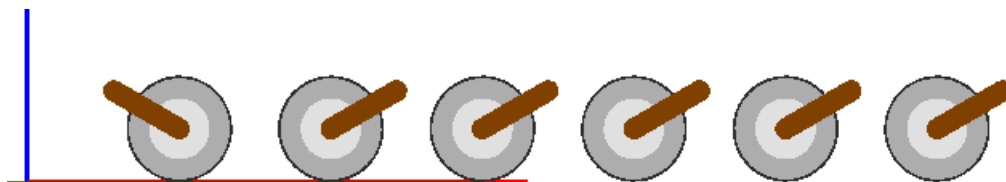

Figure 1.13. Change of the torsion arm orientation using the rear_arm identifier value

Specifying different values if the *rear_arm* identifiers for subsystems, the user can get geometrically different orientations of torsion arms in the track model, Figure 1.13. In this example, the value -1 is set for all suspension subsystems whereas the value +1 is set for the first one.

Angles α_u, α_d and torsion stiffness are computed automatically according to the formulas

$$\alpha_u = \arcsin\left(\frac{f_dyn}{l_road_arm} - \sin\alpha_{stat}\right) + \alpha_{stat}$$

$$\alpha_d = \arcsin\left(\frac{f_stat}{l_road_arm} + \sin\alpha_{stat}\right) - \alpha_{stat}$$

$$c = \frac{p_stat * l_road_arm * \cos\alpha_{stat}}{\alpha_d}$$

3. Bodies.

The model includes three bodies.

- *Local hull*, Sect. 1.1.1.4.1.1. "Standard elements and identifiers of suspension subsystems", p. 1-10.
- *Road wheel*, marked by the standard text attribute of C-type: *RoadWheel*.
- Torsion arm *Road Arm*.

Inertia parameters are presented in Table 1.3.

Table 1.3

Inertia parameters

Body	Identifier	Default value	Comments
<i>Road Wheel</i>	<i>m_road_wheel</i>	100	(kg) Mass
	<i>ix_road_wheel</i>	10	(kg m ²) Moment of inertia relative to the axis in the wheel plane
	<i>iy_road_wheel</i>	20	(kg m ²) Moment of inertia relative to the wheel symmetry axis
<i>Road Arm</i>	<i>m_road_arm</i>	50	(kg) Mass
	<i>ix_road_arm</i>	0.2	(kg m ²) Moment of inertia relative to the arm axis
	<i>iy_road_arm</i> <i>iz_road_arm</i>	3	(kg m ²) Moment of inertia relative to the axis perpendicular to the arm

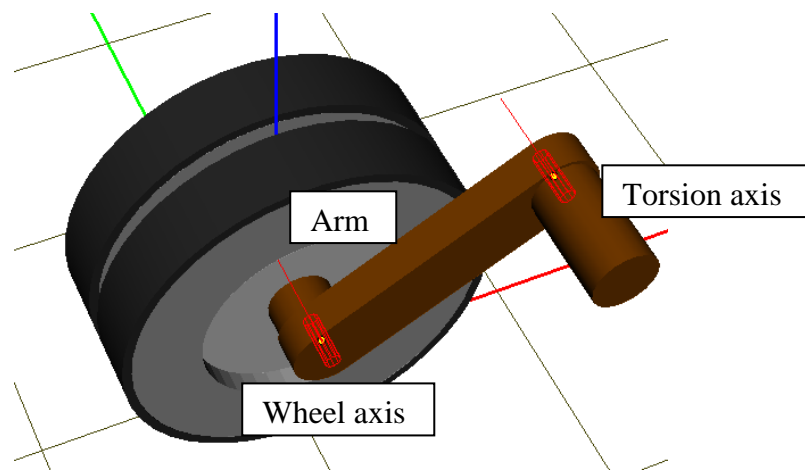

Figure 1.14. Joints in the model of torsion bar suspension

4. **Joints.**

Besides the internal joint of local hull, the model contains two rotational joints, Figure 1.14.

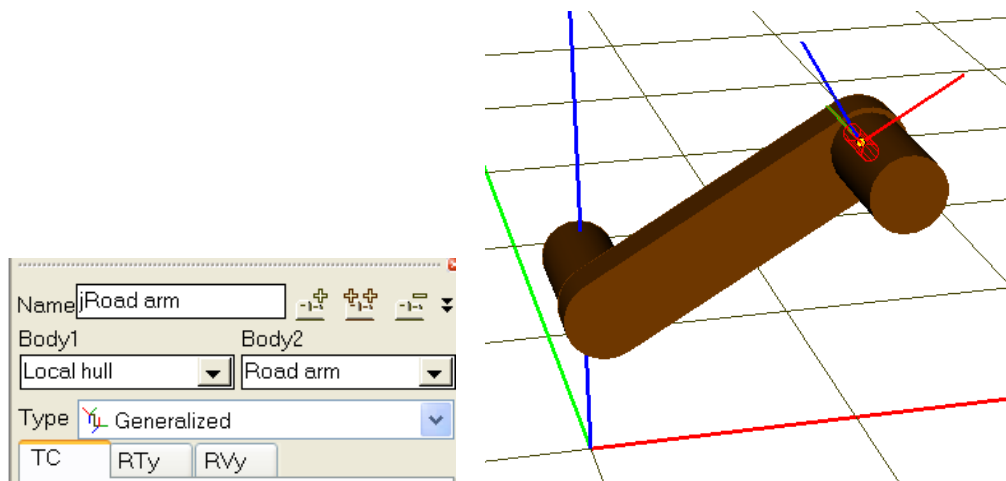

Figure 1.15. Joint *jRoad arm* and body-fixed SC

- The *jRoad arm* joint introduces a rotational degree of freedom of the torsion arm relative to the hull. In the subsystem, this joint specifies the rotation of arm (body *Road arm*) relative to the local hull (body *Local hull*). The joint is of the *generalized type* and contains three elementary transformations (ET). Consider ET in more details.

As it is known, a joint of the generalized type is described by a sequence of ET, which transforms SC of the first body to SC of the second one, Figure 1.15, [Chapter 2](#), Sect. *Joints / Generalized joint*.

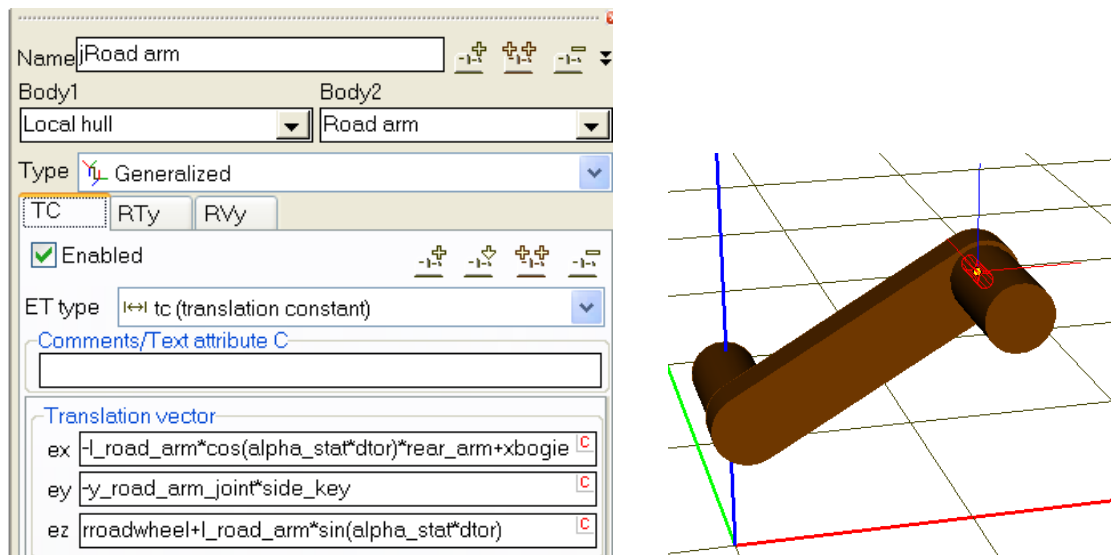

Figure 1.16. First ET: translation

The first ET of the *tc* type shifts the origin of the SC of the local hull into the joint point, which lies on the joint axis. The result of this shift is shown in Figure 1.16 by thin lines:

- shift along the X-axis is set by the expression

$$l_road_arm * \cos(\alpha_stat * dtor) + xbogie,$$

where *xbogie* is the position of wheel center relative to SC0 in X-direction; the standard identifier *drot* ($=\pi/180$) transforms degrees to radians;

- shift along the Y-axis

$$-y_road_arm_joint * side_key,$$

please note that the direction of shift depends on the value of identifier *side_key* (± 1);

- shift along the Z-axis:

$$roadwheel + l_road_arm * \sin(\alpha_stat * dtor).$$

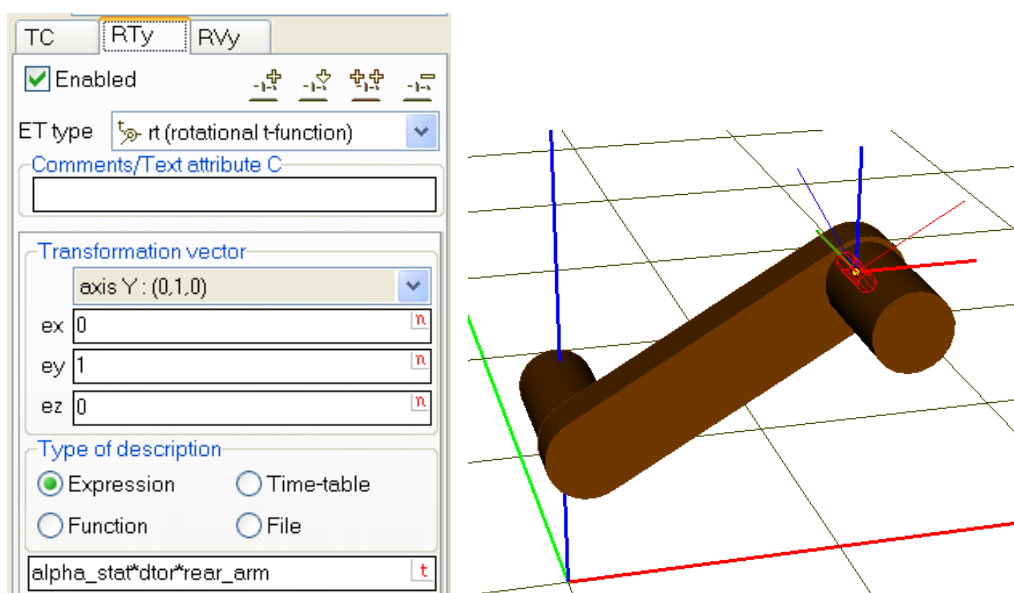

Figure 1.17. Second ET: parameterized rotation

The second ET of the *tt* type makes rotation on the *alpha_stat* angle about the joint axis, Figure 1.17.

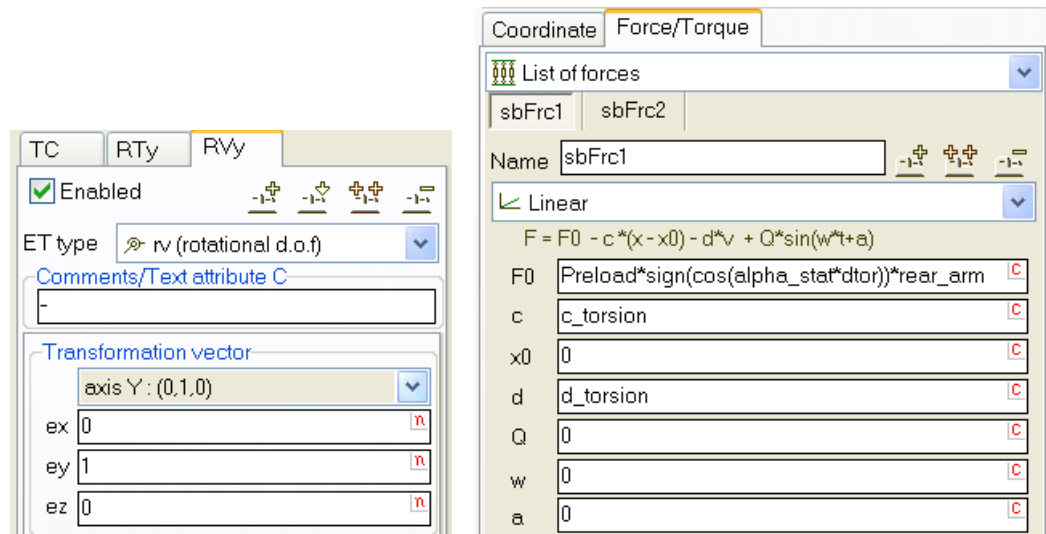

Figure 1.18. Third ET: introduction of rotational degree of freedom and joint torque

The third ET of the *tv* type introduces a rotational degree of freedom and the torsional spring as a joint torque, Figure 1.18.

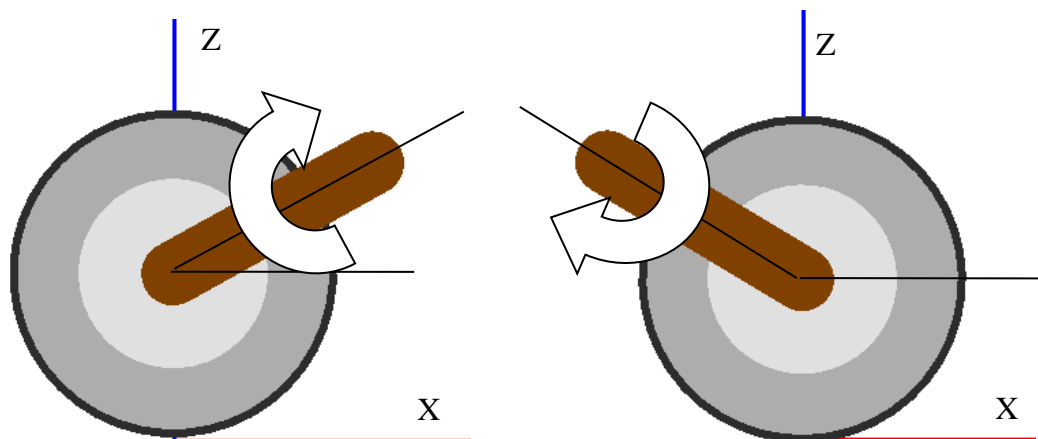

Figure 1.19. Direction of positive rotation in joint

The positive direction corresponding to decrease of the joint coordinate is shown in Figure 1.19 for different orientations of the torsion arm (identifier *rear_arm*=±1).

Parameters of torsion spring.

The linear torsion bar suspension is implemented in the model, Figure 1.18. By zero joint coordinate, the torque in joint is equal to the parameterized value preload. Direction of this torque for different orientation of the arm is shown in Figure 1.20. Torsion spring parameters are set by identifiers *c_torsion* (stiffness constant) and *d_torsion* (damping constant).

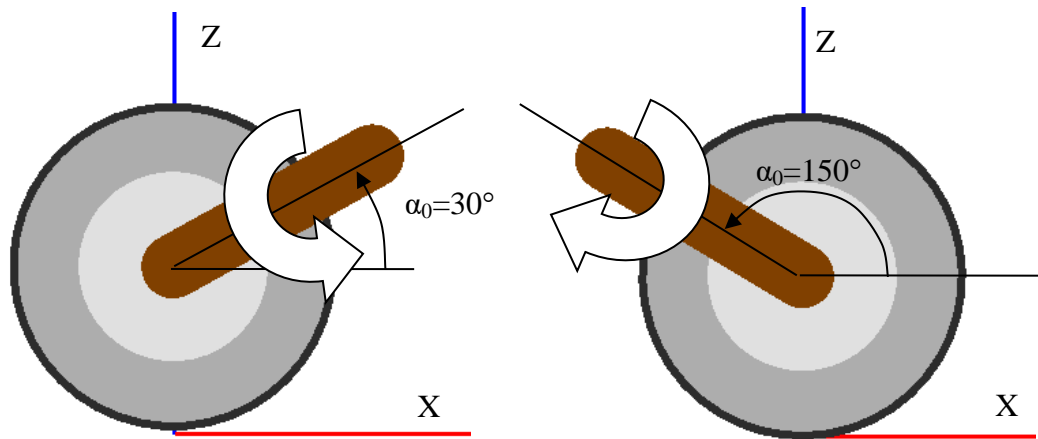

Figure 1.20. Static torques

The second nonlinear component of the joint torque realizes the limitation of upward travel f_{dyn} of the road wheel. By exceeding the travel value, a restoring torque with the parameterized stiffness c_{stop} appears, Figure 1.21, Figure 1.22, Table 1.4.

sbFrc1 | sbFrc2

Name sbFrc2

Points (symbolic)

Type of abscissa
 x v t var

Positive: compression

Type of abscissa matching
 X value F value

L 0

X(L)/F(L)

Periodic dependence

	X	Y
1	$-(\alpha_{stop_up} + \alpha_{stat}) * (1 - rear_arm) / 2 * dtor - 0.0001$	$-0.0001 * c_{stop} * (1 - rear_arm) / 2$
2	$-(\alpha_{stop_up} + \alpha_{stat}) * (1 - rear_arm) / 2 * dtor$	0
3	$(\alpha_{stop_up} + \alpha_{stat}) * (1 + rear_arm) / 2 * dtor$	0
4	$(\alpha_{stop_up} + \alpha_{stat}) * (1 + rear_arm) / 2 * dtor + 0.0001$	$0.0001 * c_{stop} * (1 + rear_arm) / 2$

Figure 1.21. Limitation of vertical travel

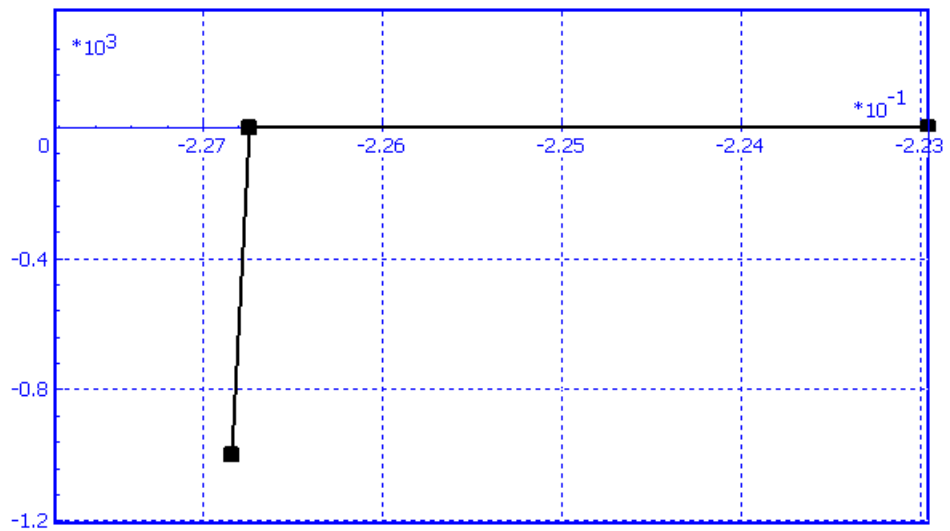

rear_arm=-1

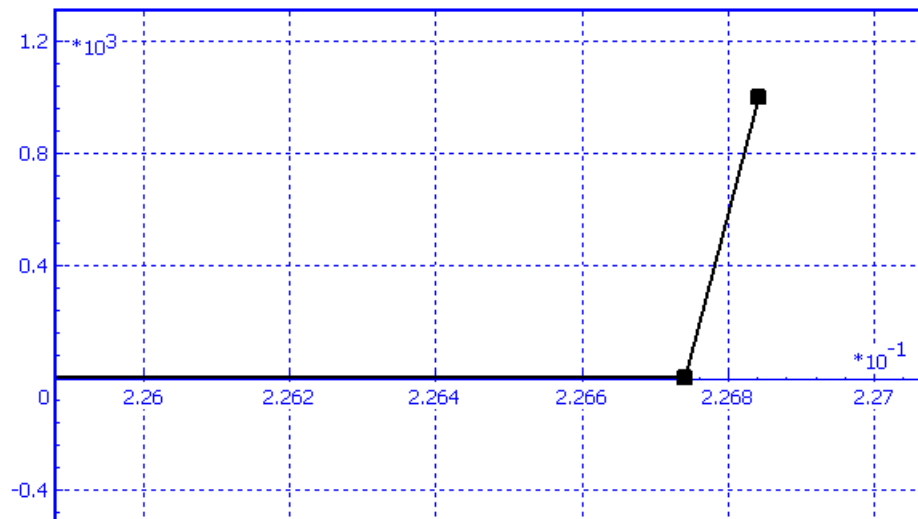

rear_arm=+1

Figure 1.22. Nonlinear limitation torque for different orientation of torsion arm

Table 1.4

Parameterization of joint torque

Identifier	Default value	Comments
preload	-	(Nm) Static torque
c_torsion	-	(Nm/rad) Torsion stiffness of suspension
d_torsion	100	(Nms/rad) Torsion damping
c_stop	10 000 000	(Nm/rad) Torsion stiffness of wheel stop

Remark. Static torque can be computed according to the following approximate formula:

$$preload \approx \frac{Mgl \cos \alpha_0}{2n}$$

Here M is the sprung mass of TV, g is the gravity acceleration, l is the arm length, $\alpha_0 = \alpha_{stat}$, n is the number of road wheels.

- The $jRoad$ wheel joint specifies a rotational degree of freedom of the road wheel relative to the arm. The lateral coordinate of the joint point is set by the expression $-y_{road_arm_joint} * side_key$.

Due to the $side_key$ identifier, this coordinate changes its sign for the left and right tracks.

5. **Images.**

- The graphic object *Road wheel* is assigned to the body of the same name.

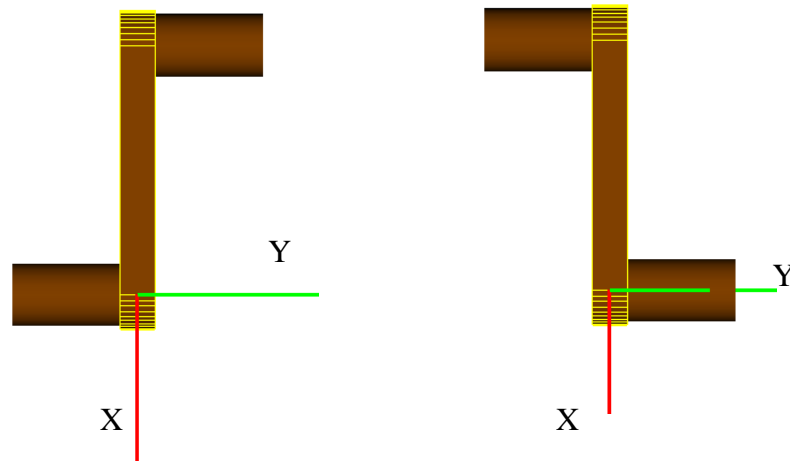

Figure 1.23. Arm image by $side_key = \pm 1$

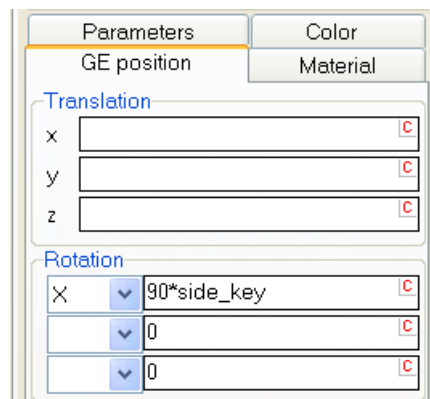

Figure 1.24. Parameterization of graphic element rotation by the identifier $side_key = \pm 1$

- The *Road arm* graphic object is assigned to the body of the same name. This graphic object must be specular reflected for the left and right tracks, Figure 1.23. To implement the reflection, parameterized rotations about the X-axis are made for two cylinders, Figure 1.24.

1.1.1.4.1.4. Suspension bogie with two wheels and two arms

Figure 1.25. Bogie with two wheels and arms

This unit models a suspension bogie with two road wheels and two arms connected by a rotational joint A, Figure 1.25, Figure 1.26. The front arm is connected with the hull by a rotational joint B. A spring connects both arms.

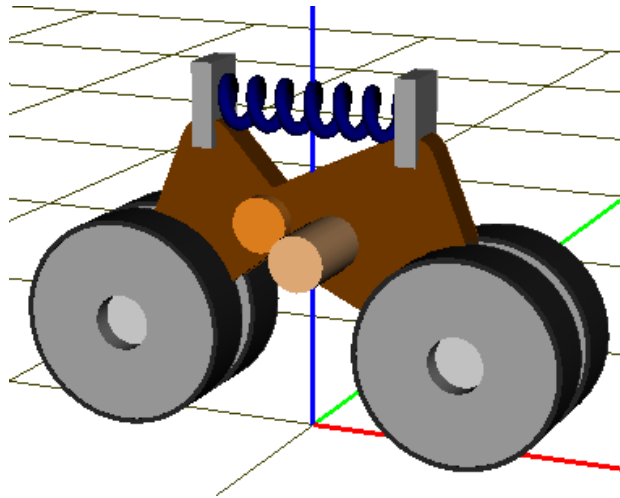
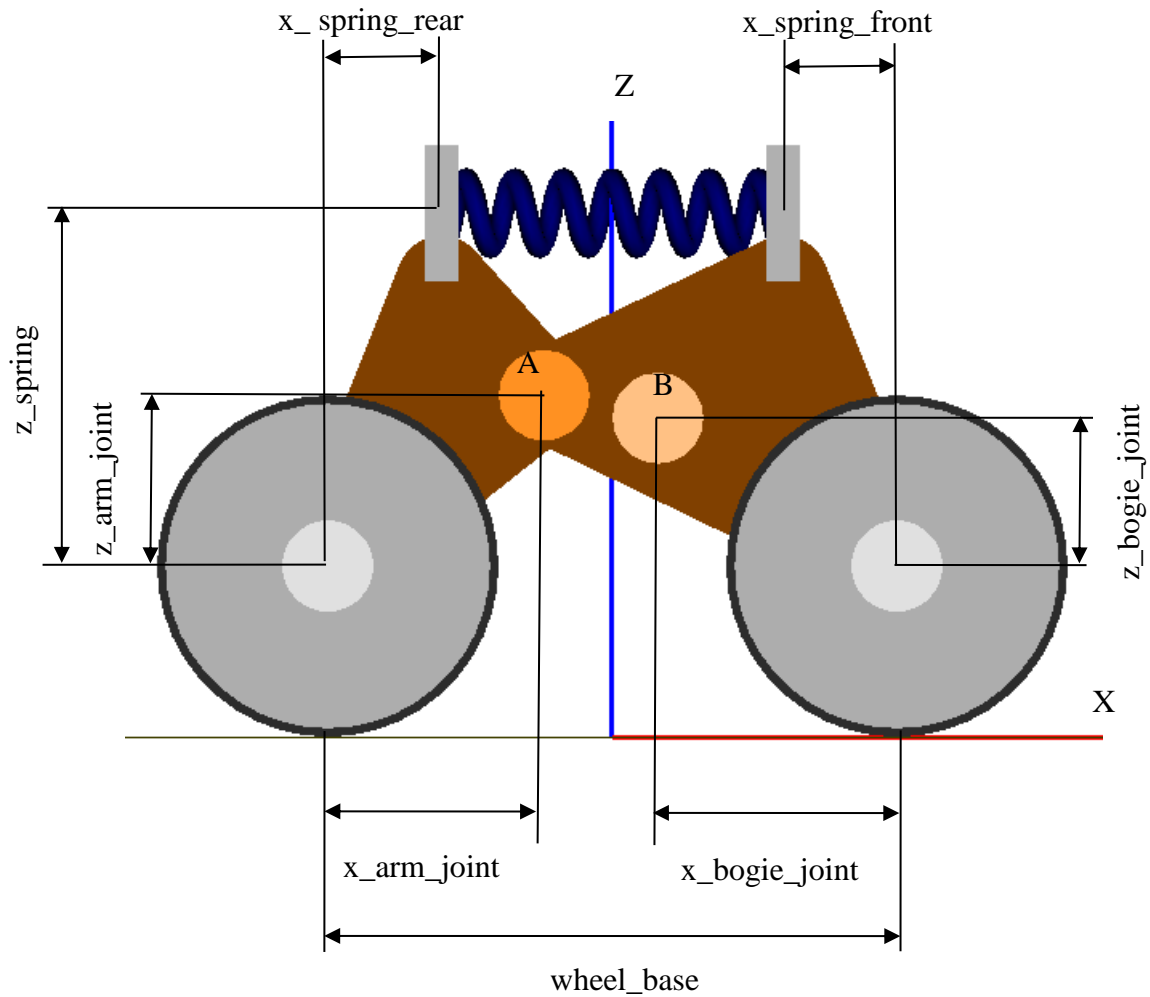

Figure 1.26. Selected identifiers

1. **Path to the component file:** {UM Data}\Caterpillar\Subsystems\bogie_2arm.dat.
2. **Selected identifiers,** Figure 1.26, Table 1.5.

Table 1.5

Identifier	Default value	Comments
wheel_base	0.5	(m) Distance between wheel centers
x_spring_front	0.1	(m) X position of front spring end relative to the center of the front wheel (positive backward)
x_spring_rear	0.1	(m) X position of rear spring end relative to the center of the rear wheel (positive forward)
x_arm_joint	0.19	(m) X, Z coordinates of joint A relative to the center of rear wheel
z_arm_joint	0.15	
x_bogie_joint	0.21	(m) X, Z coordinates of joint B relative to the center of front wheel
z_bogie_joint	0.13	

3. **Bodies.**

The model includes five bodies.

- Local hull, see Sect. 1.1.1.4.1.1. "Standard elements and identifiers of suspension subsystems", p. 1-10.
- Road wheel front, Road wheel rear marked by the standard text attribute of C-type: RoadWheel.
- Road arm front, Road arm rear.

Inertia parameters are listed in Table 1.6.

Table 1.6

Inertia parameters

Body	Identifier	Default value	Comments
<i>Road wheel front (rear)</i>	<i>m_road_wheel</i>	100	(kg) Mass
	<i>ix_road_wheel</i>	5	(kg m ²) Moment of inertia relative to the axis in the wheel plane
	<i>iy_road_wheel</i>	10	(kg m ²) Moment of inertia relative to the rotation axis
<i>Road Arm front (rear)</i>	<i>m_road_arm</i>	10	(kg) Mass
	<i>ix_road_arm</i>	1	(kg m ²) Moment of inertia relative to the central axes
	<i>iy_road_arm</i>	1	
	<i>iz_road_arm</i>	1	

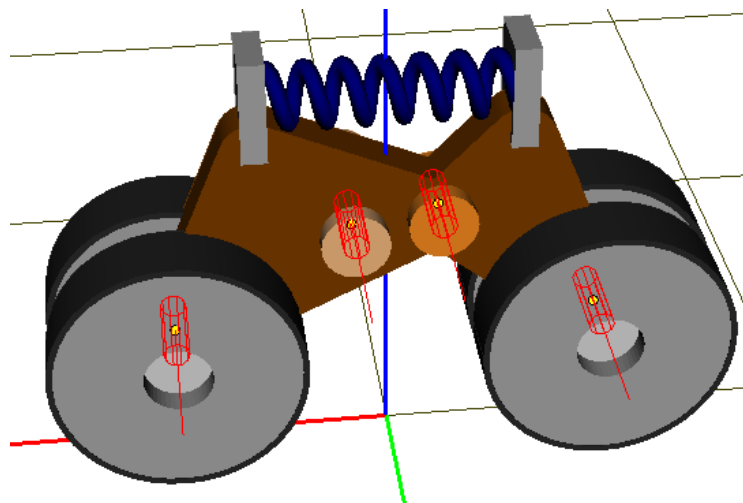

Figure 1.27. Joint of bogie with two arms

4. Joints.

Besides the internal joint of the local hull, the model of the suspension unit includes four rotational joints, Figure 1.27:

- joints connecting road wheels with arms (*jRoad wheel rear*, *jRoad wheel front*);
- joint *jRoad arm* connecting two arms (A in Figure 1.26);
- joint *jBogie* connecting the front arm with the local hull (B in Figure 1.26).

Suspension parameters.

F0	Preload	C
c	c_arm_spring	C
x0	l_arm_spring	C
d	0	C
Q	0	C
w	0	C
a	0	C

Figure 1.28. Parameters of linear force element

In the model, a linear suspension is implemented by the bipolar force element *Spring*. Type of force element: *Linear*, Figure 1.28. The force element is described by two main parameters: the preliminary load *Preload* and the spring constant *c_spring*.

The preload compensates the static load.

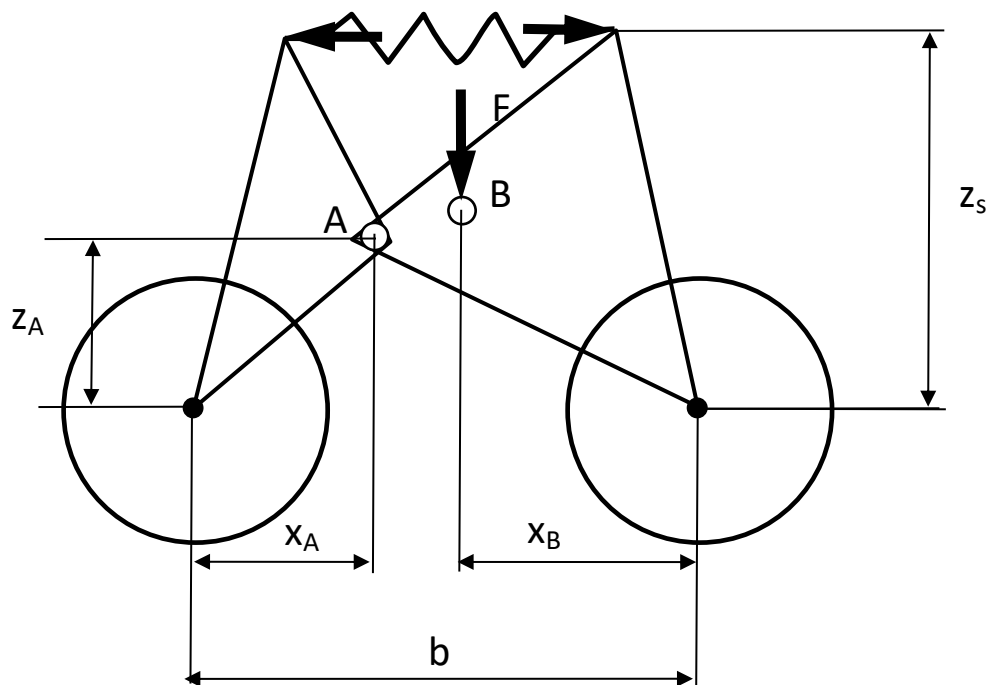

Figure 1.29. Scheme for evaluation of the preload

Using the equilibrium equations as well as the scheme in Figure 1.29, it is easy to get the spring preload value *P* by the load value *F* in joint *B*.

$$P = F \frac{x_A x_B}{b(z_s - z_A)}$$

1.1.1.4.1.5. Torsion two-wheel bogie

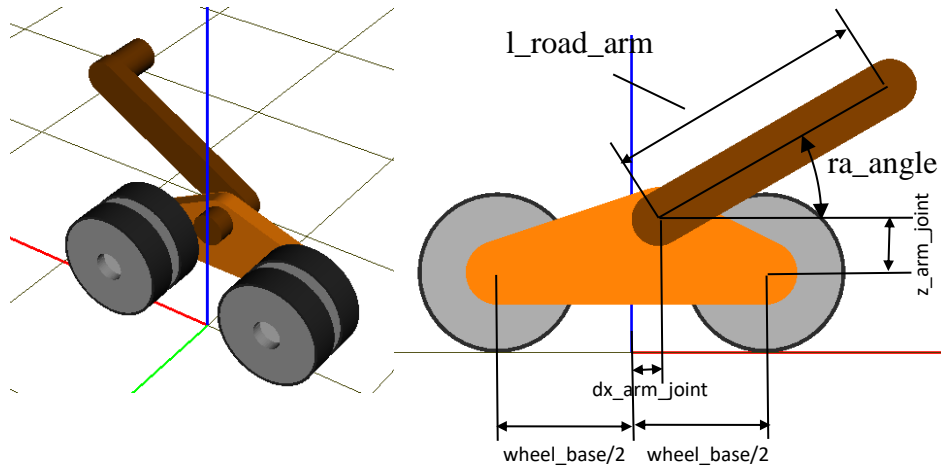

Figure 1.30. Bogie with the torsion-bar (left); selected identifiers (right)

The unit models a bogie with two road wheels and a torsion bar, Figure 1.30. The torsion bar can be replaced by a cylindrical spring connecting the arm with the hull.

1. Path to the component file:

{UM Data}\Caterpillar\Subsystems\bogie_2wheel_1arm.dat.

2. Selected identifiers, Table 1.7, Figure 1.30.

Table 1.7

Identifier	Default value	Comments
<i>wheel_base</i>	0.5	(m) distance between the wheels
<i>l_road_arm</i>	0.5	(m) Length of arm
<i>ra_angle</i>	30	(degrees) Static angle of arm to the horizontal axis
<i>z_arm_joint</i>	0.1	(m) Vertical position of bogie joint relative to the wheel centers
<i>dx_arm_joint</i>	0	(m) longitudinal shift of the arm joint

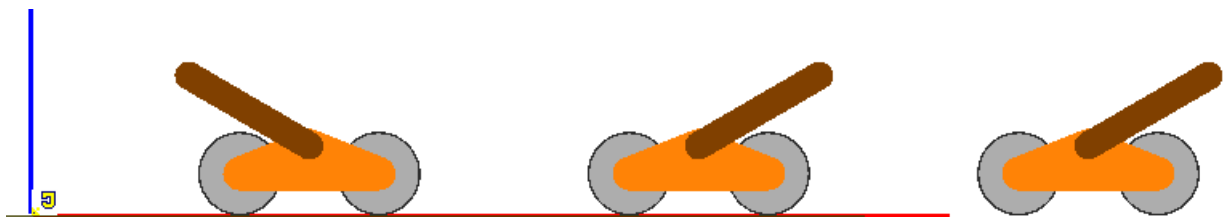

Figure 1.31. Change of the arm orientation by the static angle

Setting different values of the *ra_angle* value, the user can get various orientations of the arm, Figure 1.31.

3. **Bodies.**

The model contains four bodies.

- Local hull, Sect. 1.1.1.4.1.1. "Standard elements and identifiers of suspension subsystems", p. 1-10.
- Two wheels (*Road wheel front*, *Road wheel rear*), marked by the standard text attribute of C-type: *RoadWheel*.
- *Bogie frame*.
- *Road Arm*.

Inertia parameters are specified in Table 1.8.

Table 1.8

Inertia parameters

Body	Identifier	Default value	Comments
<i>Road Wheel</i>	<i>m_road_wheel</i>	100	(kg) Mass
	<i>ix_road_wheel</i>	10	(kg m ²) Moment of inertia relative to the axis in the wheel plane
	<i>iy_road_wheel</i>	20	(kg m ²) Moment of inertia relative to the axis perpendicular to the wheel plane
<i>Bogie frame</i>	<i>m_frame</i>	50	(kg) Mass
	<i>ix_frame</i>	3	(kg m ²) Frame moments of inertia
	<i>iy_frame</i>	10	
	<i>iz_frame</i>	10	
<i>Road Arm</i>	<i>m_road_arm</i>	50	(kg) Mass
	<i>ix_road_arm</i>	0.2	(kg m ²) Moment of inertia relative to the arm axis
	<i>iy_road_arm</i>	3	(kg m ²) Moments of inertia perpendicular to the arm axis
	<i>iz_road_arm</i>		

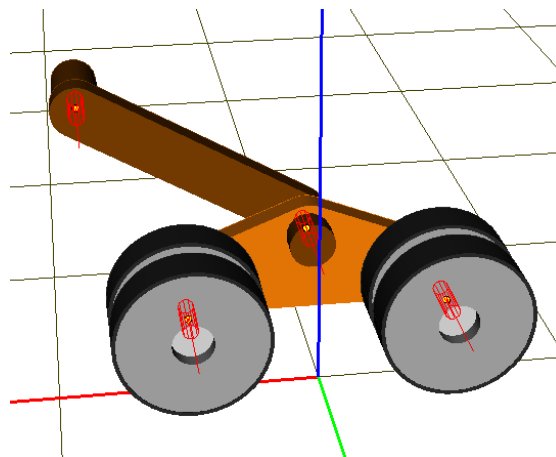

Figure 1.32. Joints

4. Joints.

Four rotational joints are shown in Figure 1.32, see Sect. 1.1.1.4.1.4. "*Suspension bogie with two wheels and two arms*", p. 1-23.

5. Suspension parameters.

A linear torsion spring is implemented in the model.

1.1.1.4.1.6. Road wheel for fixed suspension

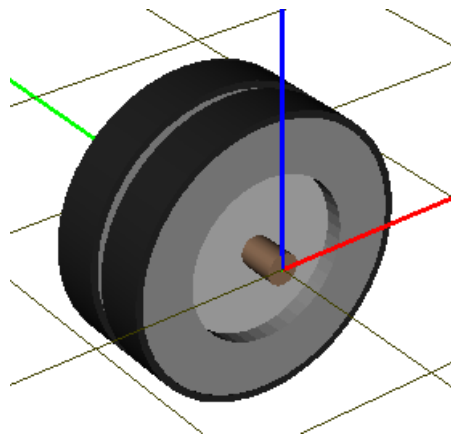

Figure 1.33. Separate road wheel

This model contains one wheel with rotational degree of freedom relative to the local hull. In case of a fixed suspension, the local hull is rigidly connected with the TV hull.

1. **Path to the component file:** {UM Data}\Caterpillar\Subsystems\Single_wheel.dat.
2. **Selected** identifiers are not used.
3. **Bodies.**

The model contains two bodies.

- *Local hull*, Sect. 1.1.1.4.1.1. "Standard elements and identifiers of suspension subsystems", p. 1-10.
- *Road wheel* marked by the standard text attribute of C-type: *RoadWheel*.

Inertia parameters are presented in Table 1.9.

Table 1.9

Inertia parameters

Body	Identifier	Default value	Comments
<i>Road Wheel</i>	<i>m_road_wheel</i>	100	(kg) Mass
	<i>ix_road_wheel</i>	10	(kg m ²) Moment of inertia relative to the axis in the wheel plane
	<i>iy_road_wheel</i>	20	(kg m ²) Moment of inertia relative to the axis perpendicular to the wheel plane

4. Joints.

One rotation joint connects the road wheel with the local hull.

1.1.1.4.2. Idler and tension device

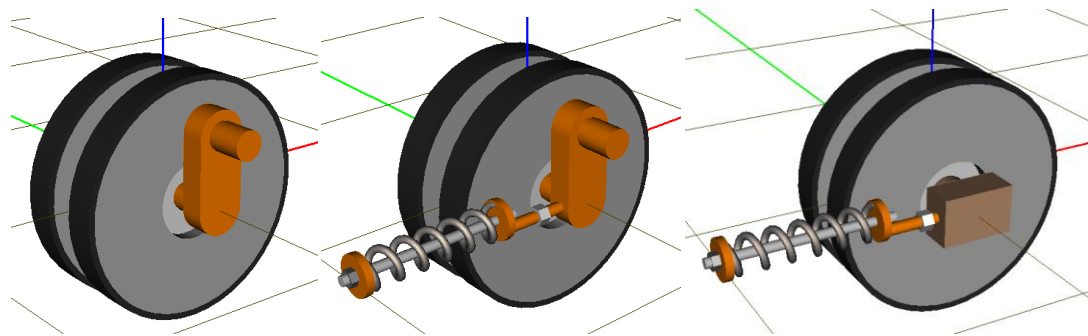

Figure 1.34. Standard models of idler with tension mechanism

As the standard models of the idler with tension device, three components are delivered with UM, which differ in the tension mechanism design:

- *idler_crank_simple* is a simplified model of the idler on a crank, Figure 1.34, left;
- *idler_crank* is a more detailed model of the idler on a crank, Figure 1.34, center;
- *idler_slider* is the model of the idler on a slider, Figure 1.34, right.

Standard elements

1. **Standard identifiers:** any component describing the idler must contain standard identifiers, Table 1.10, Figure 1.48.

Table 1.10

Identifier	Comments
<i>ridler</i>	(m) Radius of idles
<i>widler</i>	(m) Width of idler
<i>side_key</i>	Key: left (1) or right (-1) track. The identifier should be used as a factor by lateral geometrical parameters, which have different signs for the left and right tracks
<i>wguide</i>	Width of a slot in the wheel for run of track teeth
<i>hguide</i>	Depth of a slot in the wheel for run of track teeth
<i>xcidler</i>	X coordinate of idler axis
<i>zcidler</i>	Z coordinate of idler axis
<i>rear_drive_key</i>	Key for position of drive wheel: 1 (rear), -1 (front)

2. **Standard element:** a text attribute for idler identification. An idler body must be marked by a standard text attribute of C-type: *Idler*, Figure 1.35.

3. **Description of elements connected with the TV hull.**

In opposite to the suspension components, description of the idler does not include a subsystem and a local hull. All elements connected with the TV hull, are coupled with *Base0*. By including a component in the model of a track, the base body is replaced automatically by the track local hull.

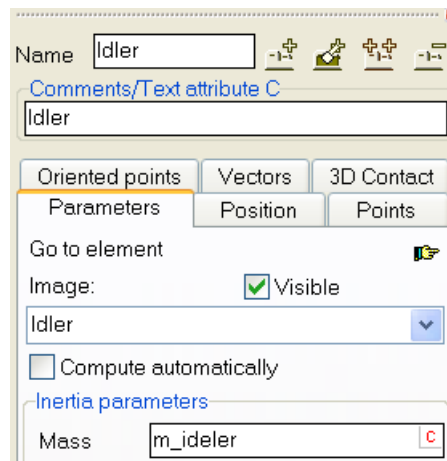

Figure 1.35. Standard text attribute for idler

The idler components are similar, and we consider the first of them in a little bit more details.

1.1.1.4.2.1. Idler on a crank. A simplified model

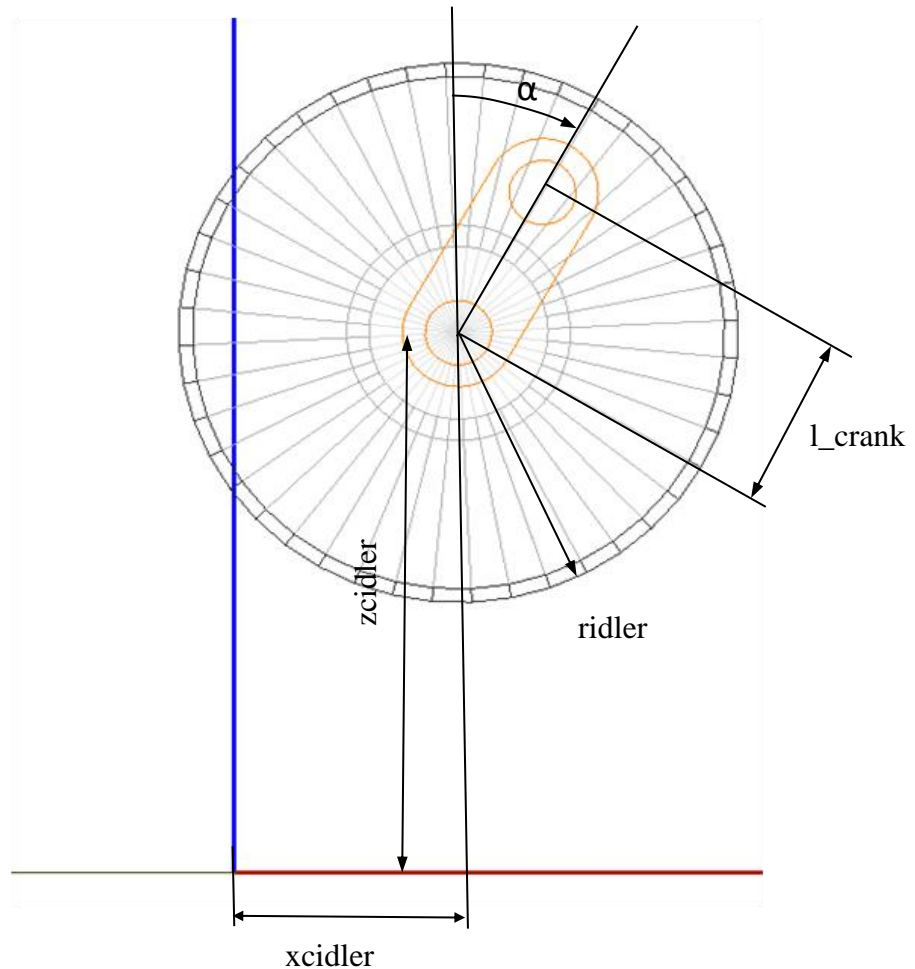

Figure 1.36. Geometric parameters of the model

Consider a simplified model of an idler with a crank, Figure 1.36. The name of the component is *idler_crank_simple*. Simplification of the component in comparison with the more detailed one (*idler_crank*) consists in reduction of force parameters to the rotational joint connecting the idler and the TV hull.

The model contains the idler and crank connected by a rotational joint, as well as a joint connecting the idler with the hull.

1. **Path to the component file:**

{UM Data}\Caterpillar\Subsystems\idler_crank_simple.dat.

2. **Identifiers.** In addition to identifiers listed in Table 1.10, a number of identifiers are used for description of geometric parameters of the model, Table 1.11, Figure 1.36.

Table 1.11

Identifier	Comments
<i>l_crank</i>	(m) Length of crank is the distance between the rotational joints
<i>crank_angle_0</i>	(Degrees) Angle α is the nominal orientation of the crank. Direction of the rotation depends on the identifier rear_drive_key. Positive direction for rear_drive_key=1 is shown in Figure 1.36.

3. Bodies.

The model contains two bodies.

- *Idler* body marked by the standard text attribute of C-type: *Idler*.
- *Tension crank*.

Inertia parameters are listed in Table 1.12.

Table 1.12

Inertia parameters

Body	Identifier	Default value	Comments
<i>Idler</i>	<i>m_idler</i>	100	(kg) Mass
	<i>ix_idler</i>	7	(kg m ²) Moment of inertia relative to the axis in the wheel plane
	<i>iy_idler</i>	15	(kg m ²) Moment of inertia relative to the axis perpendicular to the wheel plane
<i>Tension crank</i>	<i>m_crank</i>	10	(kg) Mass
	<i>ix_crank</i>	1	(kg m ²) Moment of inertia of the crank
	<i>iy_crank</i>		
	<i>iz_crank</i>		

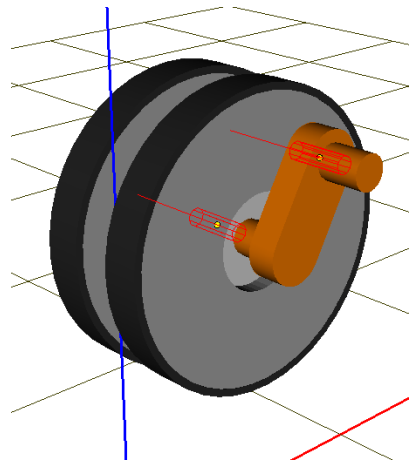

Figure 1.37. Joints

4. Joints.

The model contains two rotational joints, Figure 1.37.

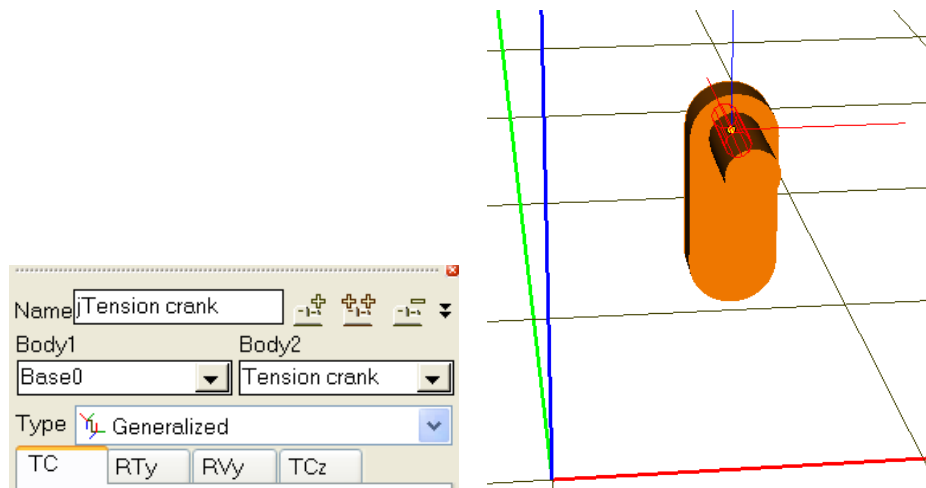

Figure 1.38. Joint *jTension* crank and body-fixed SC

The *jTension crank* joint introduces a rotational degree of freedom of the crank relative to the hull. In the component model, this joint connects the crank with *Base0*. The joint is of the generalized type and includes four elementary transformations (ET). Consider ET in more details.

As it is known, the generalized joint specifies a sequence of ET, which transforms system of coordinates of the first body to that of the second one, Figure 1.15, [Chapter 2](#), Sect. *Joints / Generalized joint*.

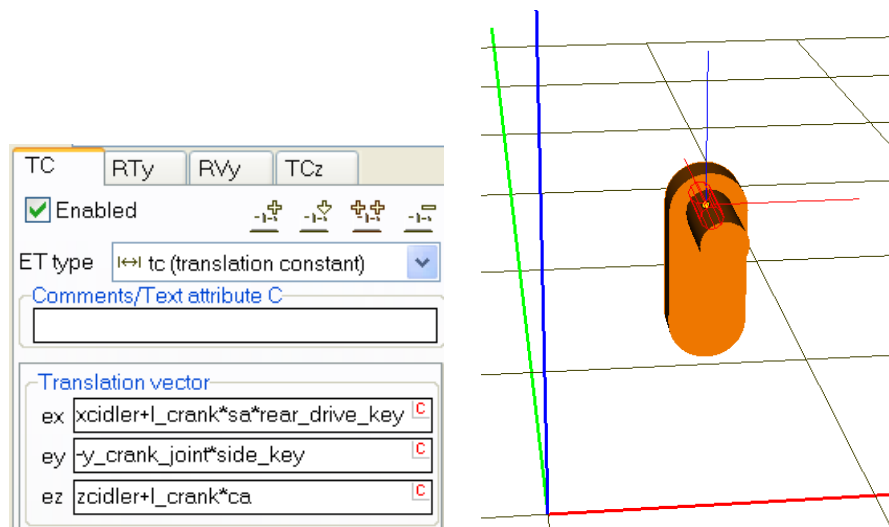

Figure 1.39. The first ET: translation

The first ET of the *tc* type shifts the origin of SC of the first body into the joint point lying on the axis of rotation. The result is show in Figure 1.39 by thin lines:

- shift along the X-axis is set by the expression

$$xcidler+l_crank*sa*rear_drive_key,$$

where the *xcidler* identifiers corresponds to the position of the idler wheel center in the longitudinal direction, $sa = \sin(\text{crank_angle}_0 * \text{dtor})$;

- shift along the Y-axis

$$-y_crank_joint*side_key,$$

note that the direction of the lateral shift depends on the identifier *side_key* (± 1);

- shift along the Z-axis:

$$z_{cidler} + l_{crank} * ca,$$

$$ca = \cos(\text{crank_angle_0} * dtor)$$

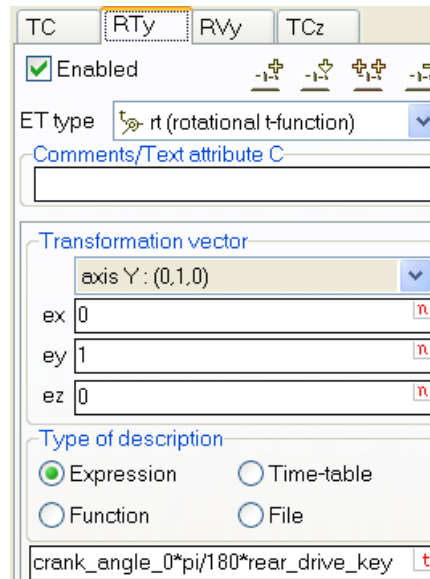

Figure 1.40. The second ET: rotation on a parameterized angle

The second ET of the *tt* type realizes a rotation about the joint axis on the angle, which is parameterized by the identifier *crank_angle_0* (angle α in Figure 1.36), Figure 1.40.

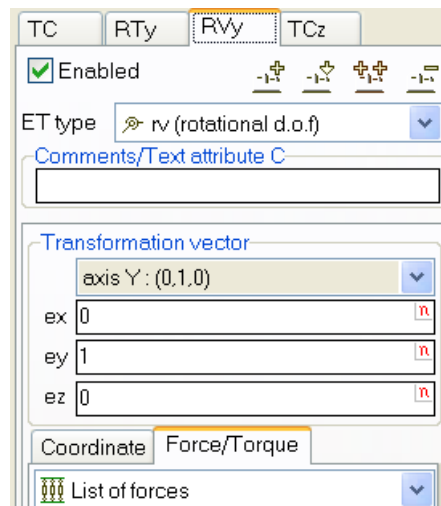

Figure 1.41. The third ET: rotational degree of freedom

The third ET of the *tv* type introduces the rotational degree of freedom, Figure 1.41. In this ET, a joint torque is described corresponding to the realization of the tension mechanism.

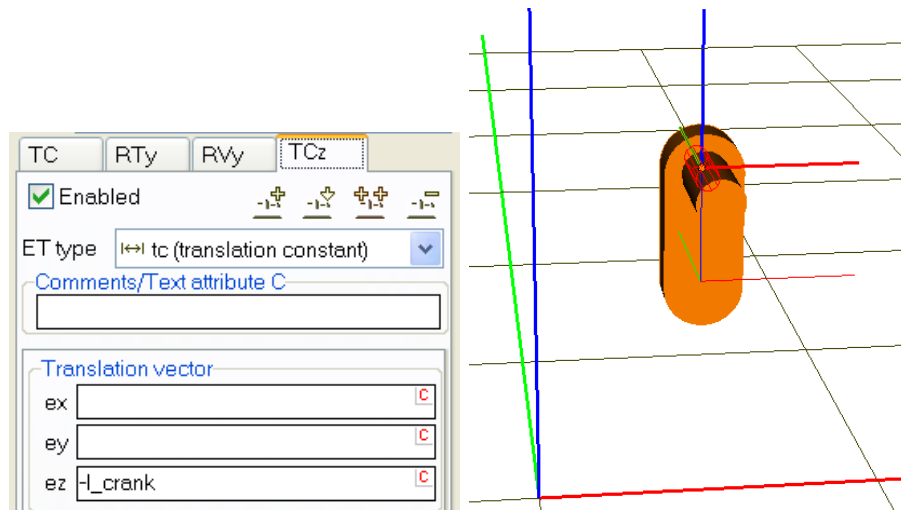

Figure 1.42. The fourth ET: shift to the crank-fixed SC (thick lines)

The final fourth ET of the *tc* type transforms the SC to the SC of the crank, Figure 1.42.

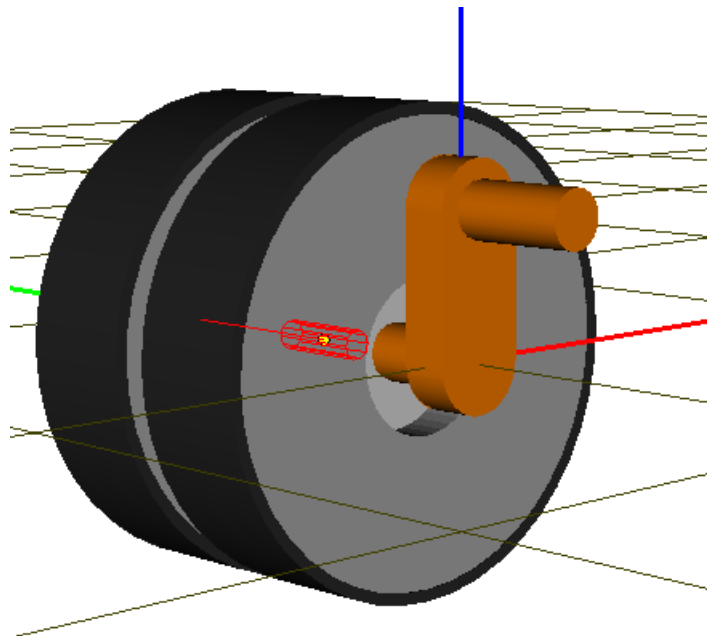

Figure 1.43. Joint *jIdler_Tension* crank

The rotational joint *jIdler_Tension* crank introduces a rotational degree of freedom of the idler relative to the crank, Figure 1.43.

5. Joint torque realizing the tension device

The model of tension mechanism realizes the following properties of the real prototype:

- preliminary load of tension spring (identifier *pretension*);
- linear stiffness of tension spring by compression forces exceeding the preload force (identifier *c_tension_spring*);
- blocking properties of the device by stretching;

- possibility of getting a desirable track tension by change of the unloaded length of the tension device; change in length is parameterized by the identifier $dl_tension_rod$, and increase of this value leads to the increase of the tension.

In the simplified model considered in the current section, the listed properties are implemented by a nonlinear joint torque with a simplified reduction of tension spring properties to the crank joint:

- $d_tension_angle=dl_tension_rod/l_crank$ is the angular analog of change the spring length;
- $pretension_torque=pretension*l_crank$ is the preload torque;
- $c_torsional=c_tension_spring*sqr(l_crank)$ is the torsion stiffness approximating the linear spring stiffness.

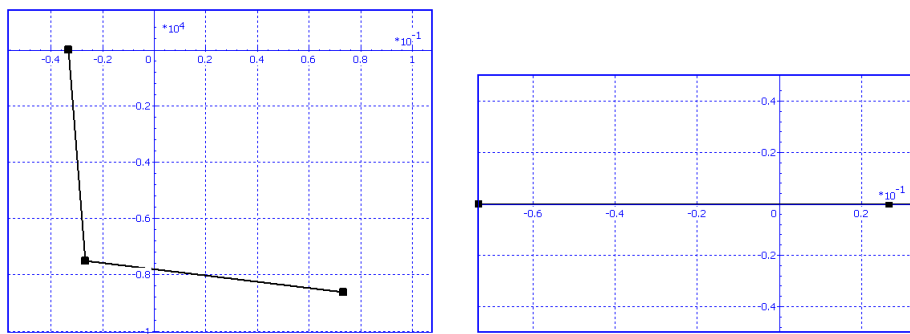

rear_drive_key=1

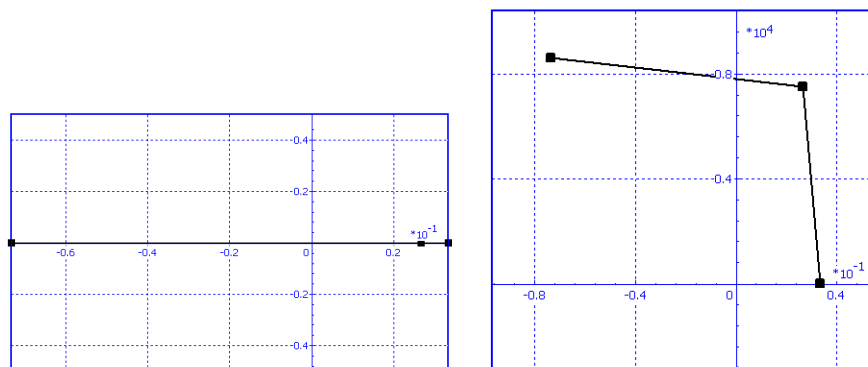

rear_drive_key=-1

Figure 1.44. Force characteristics of joint torque for TV with rear / front drive $dl_tension_rod=5$ mm

The joint torque description includes two components one of which is enabled for a rear drive TV ($rear_drive_key=1$), and the second one for the front drive TV ($rear_drive_key=-1$), Figure 1.44. The steep part of the plot corresponds to the blocking properties of the device by stretching and compression up to the value of the preload. The part with the low grade inclination models the absorbing of the mechanism by compression behind the preload.

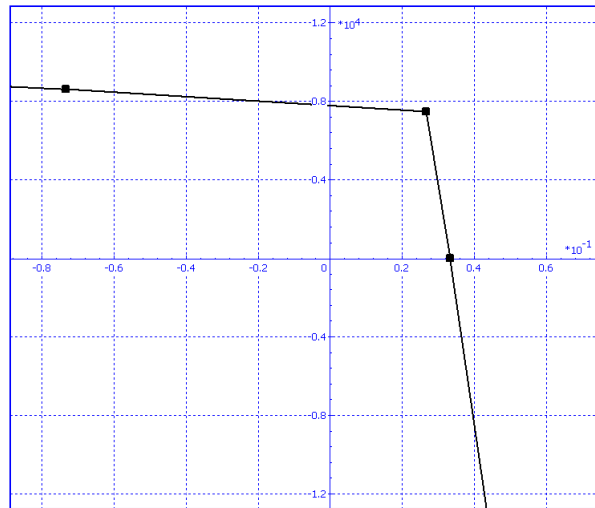

Figure 1.45. Linear approximation of the characteristics out of the definition region

Remark. The user must keep in mind that a linear approximation of the characteristics takes place for abscissa value out of the definition region, Figure 1.45.

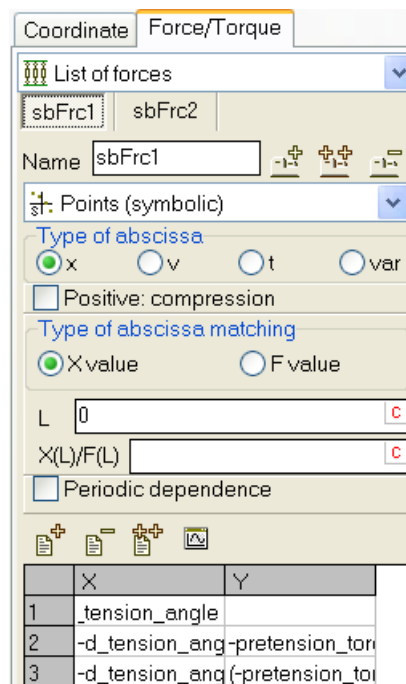

Figure 1.46. Joint torque

	X	Y
1	-d_tension_angle	
2	-d_tension_angle+pretension_torque/c_torsional/100	-pretension_torque*(rear_drive_key+1)/2
3	-d_tension_angle+pretension_torque/c_torsional/100+0.1	(-pretension_torque-c_torsional*0.1)*(rear_drive_key+1)/2

a)

	X	Y
1	$d_tension_angle - pretension_torque / c_torsional / 100 - 0.1$	$(pretension_torque + c_torsional * 0.1) * (1 - rear_drive_key) / 2$
2	$d_tension_angle - pretension_torque / c_torsional / 100$	$pretension_torque * (1 - rear_drive_key) / 2$
3	$d_tension_angle$	

b)

Figure 1.47. Mathematical models of joint torque enabled by *rear_drive_key*=1 (a) and *rear_drive_key*=-1 (b)

The joint torque is of the **List of forces** type, which includes two elements of the **Points (symbolic)** type, Figure 1.46, Figure 1.47.

1.1.1.4.2.2. Idler on a crank. A more detailed model

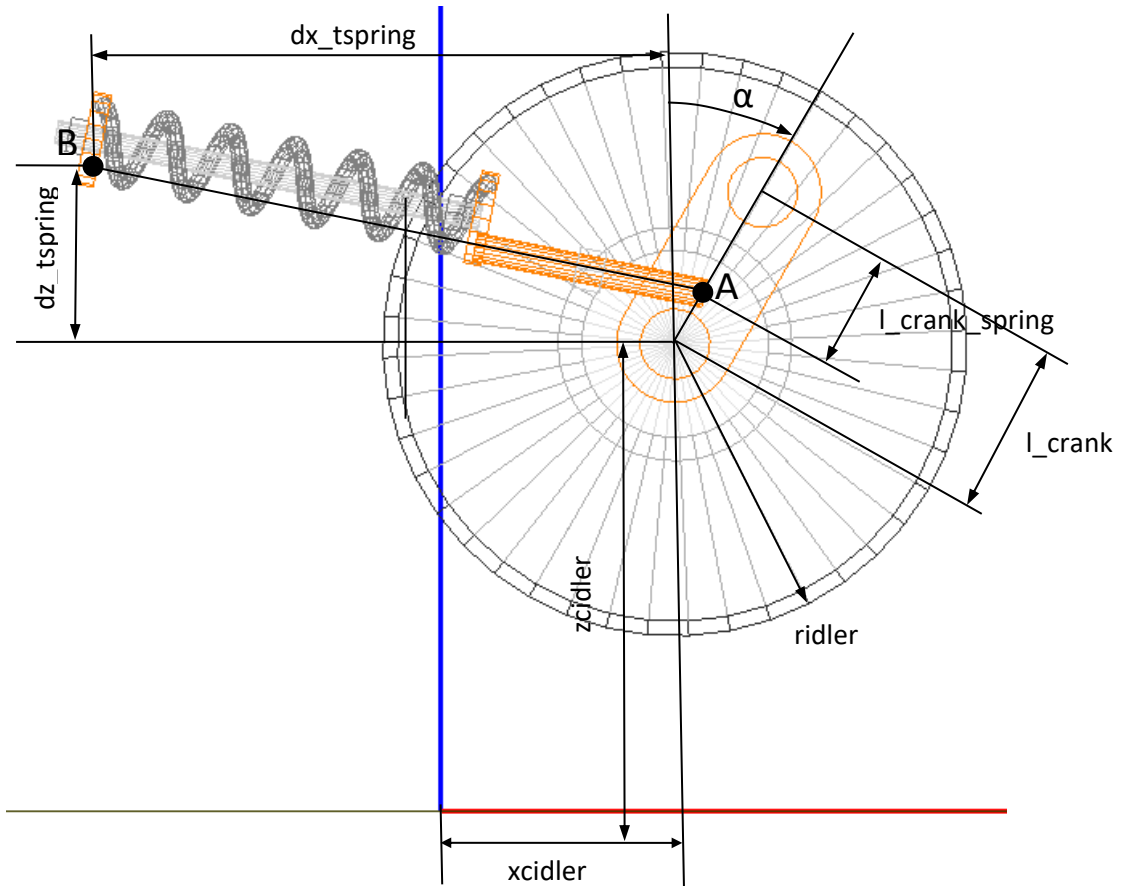

Figure 1.48. Parameterization of model geometry

As opposite to the previous section, here the tension device is described in more details. The force element is attached to the crank in point A, and to *Base0* in point B, Figure 1.48.

1. Path to the component file: {UM Data}\Caterpillar\Subsystems\idler_crank.dat.
2. **Identifiers.** In addition to parameters in Table 1.10 and Table 1.11, some identifiers are user for parameterization of the model geometry, Table 1.13, Figure 1.48.

Table 1.13

Identifier	Comments
l_crank_spring	(m) Distance between the crank/hull joint and point A.
dx_tspring, dz_tspring	(m) Position of B point relative to the wheel center

3. **Bodies.** See the previous section.
4. **Joints.** See the previous section. The difference consists in the lack of the joint torque.
5. **Tension force element.**

A bipolar force element *Tension spring* is used for modeling the tension device. It realizes the properties mentioned in the previous section. The force characteristic is similar to that in Figure 1.48 by *rear_drive_key*=1,

$$pretension+heavi(l_tension_spring-x)*c_tenstion_spring*(l_tension_spring-x)+$$

$$\text{heavi}(-l_{\text{tension_spring}}+x)*(-c_{\text{tension_spring}}*100*(-l_{\text{tension_spring}}+x))$$

where x is the element length, $l_{\text{tension_spring}}$ is the length of unloaded element, pretension is the identifier for the preload force, $c_{\text{tension_spring}}$ is the spring constant; the Heaviside function is

$$\text{heavi}(x) = \begin{cases} 1, & x > 0 \\ 0, & x \leq 0 \end{cases}$$

The length of unloaded element is expressed in terms of geometric and force parameters of the model as

$$l_{\text{tension_spring}} = \sqrt{(\sqrt{dx_{\text{tspring}}+dl_{\text{crank_spring}}*sa}) + \sqrt{dz_{\text{tspring}}-dl_{\text{crank_spring}}*ca}} + dl_{\text{tension_rod}} - \text{pretension}/c_{\text{tension_spring}}/100$$

This expression consists of three parts.

- $\sqrt{(\sqrt{dx_{\text{tspring}}+dl_{\text{crank_spring}}*sa}) + \sqrt{dz_{\text{tspring}}-dl_{\text{crank_spring}}*ca}}$ is the length of element by zero value of object coordinates;
- $dl_{\text{tension_rod}}$ is an additional change in the element length; the length of the element is increased with the parameter $dl_{\text{tension_rod}}$, so that change of the latter can be used for generation of the desired tension of the track in case track links with rigid joints;
- $\text{pretension}/c_{\text{tension_spring}}/100$ is an additional term which provides the zero value of force for zero value of elongation $dl_{\text{tension_rod}}=0$.

1.1.1.4.3. Sprocket

1.1.1.4.3.1. Geometrical parameters of sprocket

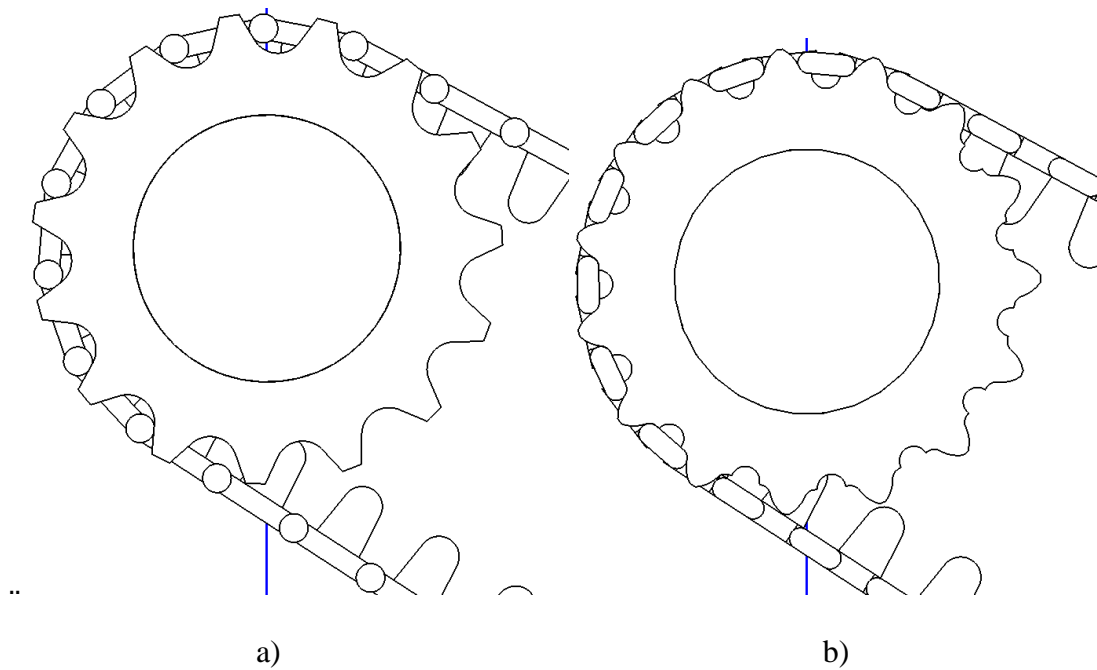

Figure 1.49. Fragments of track models: track links with one joint (a) and with parallel joints (b)

The following track joint types are implemented in UM:

- rigid joints, Figure 1.49a,
- one flexible joint (bushing) for a track link, Figure 1.49a,
- two parallel flexible joints for a track link, Figure 1.49b.

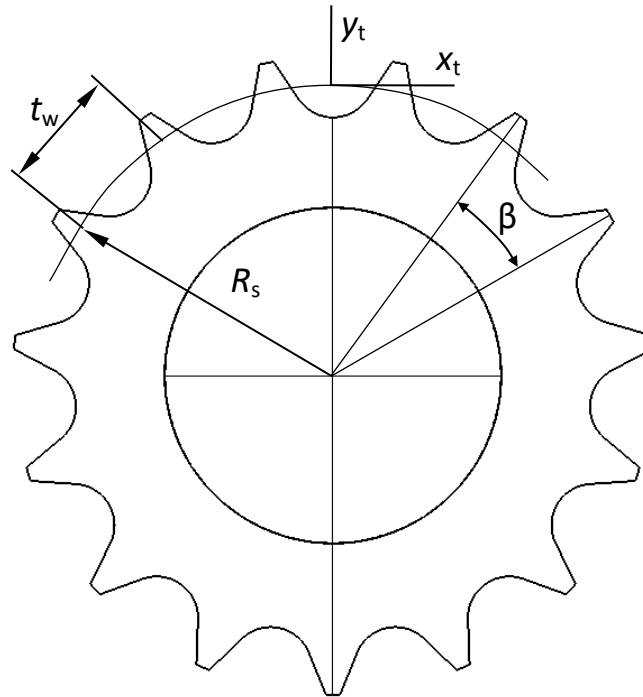

Figure 1.50. Parameters of a sprocket for a track with one joint in a link

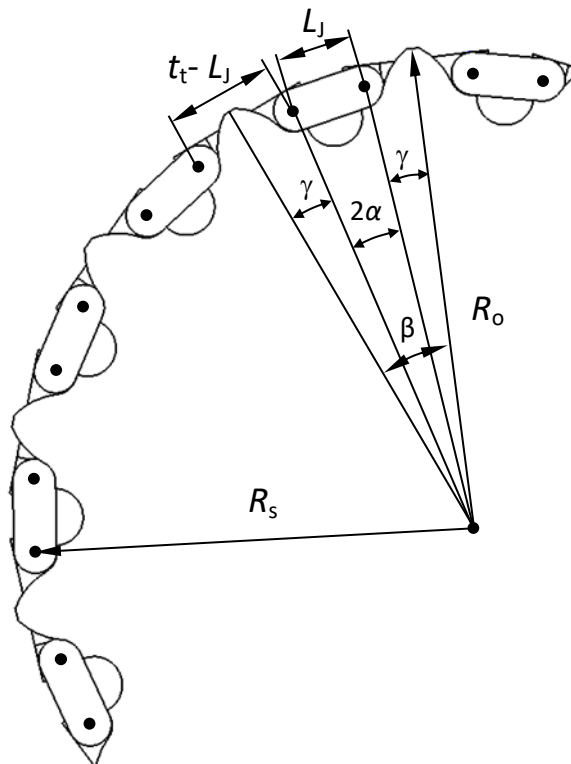

Figure 1.51. Parameters of a sprocket for a track with parallel joints

Main parameters specifying sprocket geometry are (Figure 1.50, Figure 1.51):

- number of teeth Z ;
- wheel radius on pin centers R_s ;

- wheel radius of tooth tops R_o ;
- tooth height over the pin center radius $h = R_o - R_s$.
- wheel step t_w ;
- track step t_t ;
- distance between parallel joint of links L_j ;
- step ratio $D = t_w/t_t$

The user should set three parameters from this list: Z , t_t and D . Other parameters for a track with one joint for a link are computed according to formulas

$$t_w = Dt_t,$$

$$R_s = \frac{t_w}{2 \sin \beta/2} = \frac{t_w}{2 \sin \pi/Z}$$

In the case of a track with parallel joints, the R_s radius is computed according to the formula (Figure 1.51)

$$t_w - L_j + L_j \cos \frac{\beta}{2} = \sin \frac{\beta}{2} \sqrt{4R_s^2 - L_j^2},$$

i.e.

$$R_s = \frac{1}{2} \sqrt{\frac{(t_w - L_j + L_j \cos \beta/2)^2}{\sin^2 \beta/2} + L_j^2}.$$

In addition, sprocket geometry requires the description of tooth profile.

1.1.1.4.3.2. Automatic generator of sprocket tooth profiles

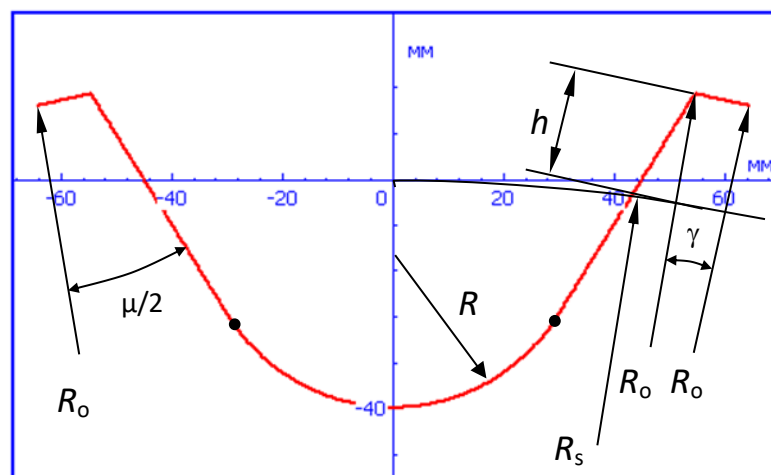

Figure 1.52. Template of sprocket profile for track with one joint a link

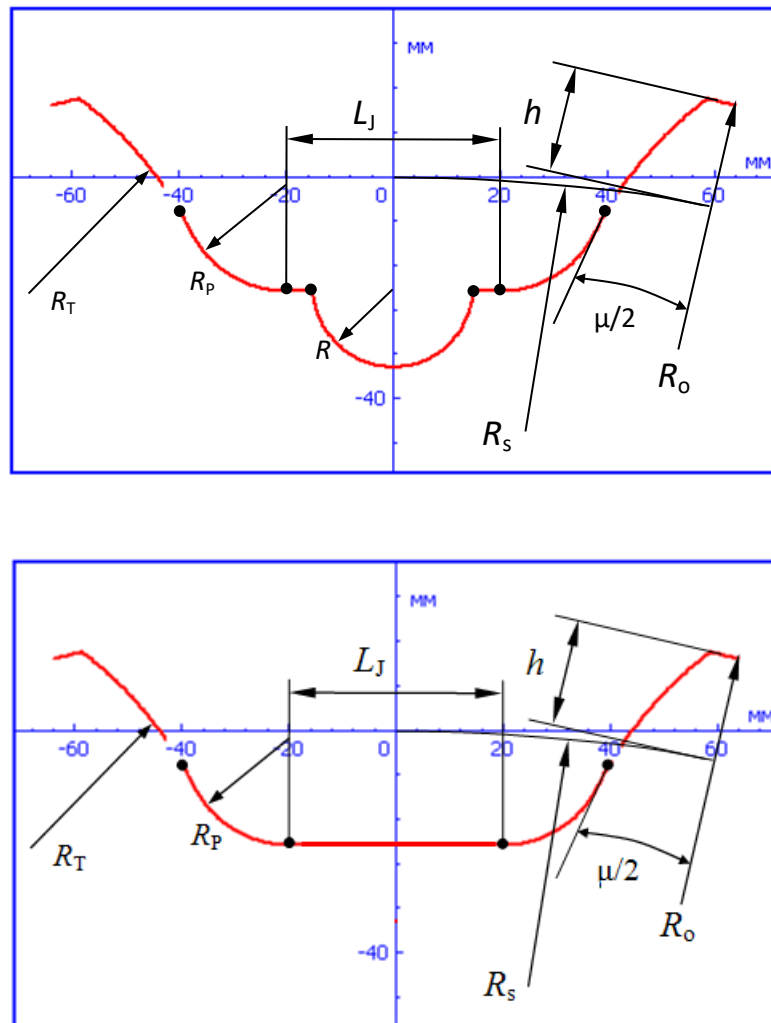
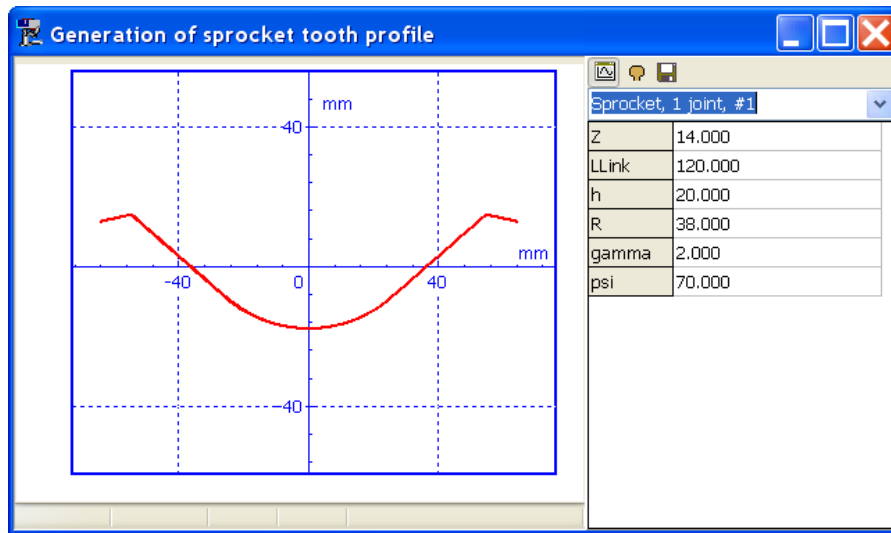

Figure 1.53. Templates of sprocket profile for track with parallel joints

Some sprocket tooth profiles can be generated in UN automatically, Figure 1.52, Figure 1.53. To generate a profile, the following steps are necessary.

1. Run input program **UM Input**.
2. Open a tool for generation of profiles by the **Tools | Generator of sprocket tooth...** menu command.
3. Select a type of profile from the drop-down list:



a)

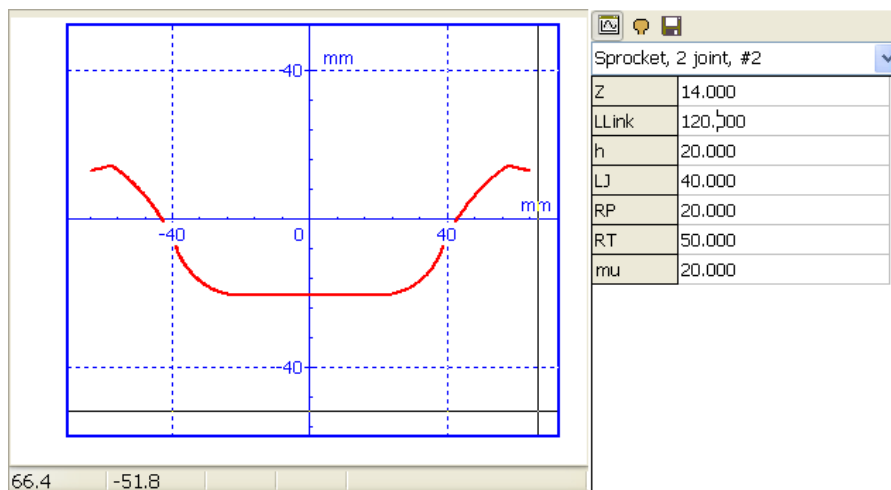
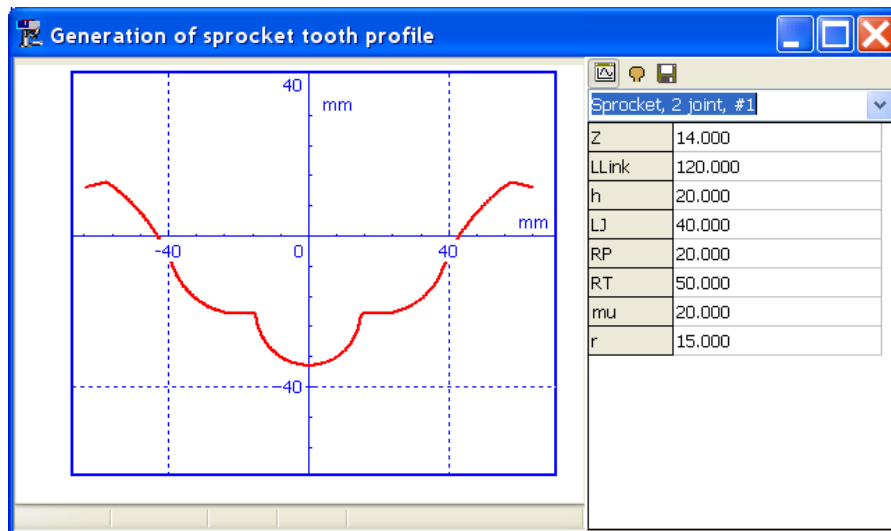

b)



Figure 1.54. Parameters of sprocket profiles

4. Set profile parameters.

- **Sprocket, 1 joint, #1**, Figure 1.52, Figure 1.54a; list of parameters:
 - number of teeth **Z**;
 - Sprocket step **LLink** = t_w , mm;
 - Tooth height over the pin center radius $h = R_0 - R_s$, mm;
 - radius of tooth root **R**, mm;
 - tooth central angle **gamma**, degrees;
 - tooth wedge angle **psi**, degrees;
- **Sprocket, 2 joint, #1,2**, Figure 1.53, Figure 1.54b; list of parameters:
 - number of teeth **Z**;
 - Sprocket step **LLink** = t_w , mm;
 - Tooth height over the pin center radius $h = R_0 - R_s$, mm;
 - distance between parallel joint of links **LJ**, mm;
 - radius of pin **RP**, mm;
 - tooth profile radius **RT**, mm;
 - radius of tooth root **R**, mm;
 - tooth angle **mu** measured at the trimming point of circles **RT** and **RP**, degrees.

Use the  button to compute and plot the profile.

Save the profile to file by the  button.

The buttons   are used for getting either the current profile plot (Figure 1.54) or a plot template, Figure 1.52, Figure 1.53.

Remark. Length parameters are set in millimeters, but they are converted to meters by saving in file.

1.1.1.4.3.3. Creation of profile by curve editor

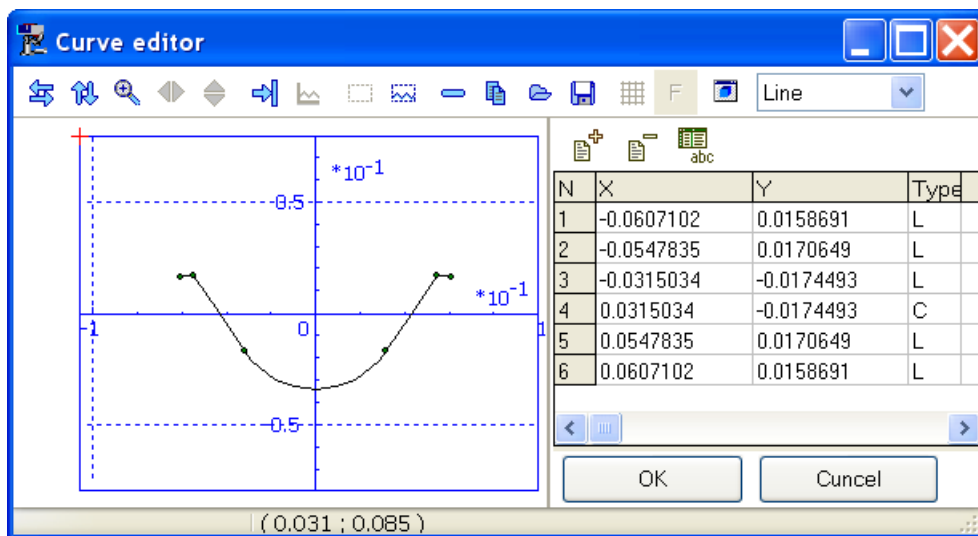

Figure 1.55. Tooth profile in the curve editor

A tooth profile can be created in the built-in curve editor. The profile is specified by a sequence of points in the system of coordinates $x_t y_t$. The origin of this system of coordinate is lo-

cated on the circle passing through the pin profile centers in the middle of center the tooth root, Figure 1.50, Figure 1.55. Description of the curve editor functions can be found in [Chapter 3](#), Sect. *Object constructor / Curve editor*.

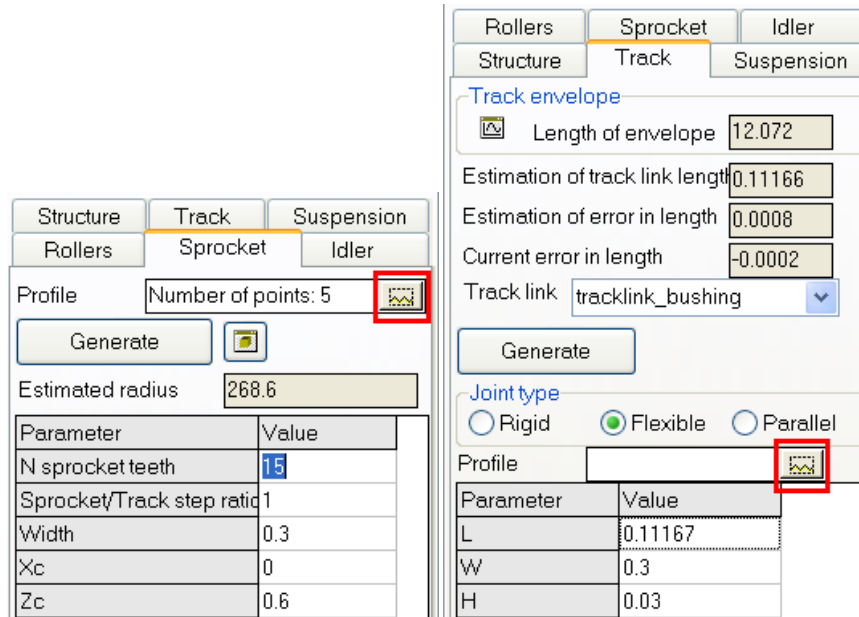



Figure 1.56. Creation and modification of sprocket and pin profiles

The buttons  in the **Sprocket** and **Track** tabs of the track wizard are used to call the editor, Figure 1.56.

Coordinates are set in meters.

One of the possible ways of creating the profiles consists in use of external editors. Coordinates of points should be written in a text file in two columns with the space character as a separator. The first column contains abscissa values in the increasing order. Example:

```

-0.0607102  0.0158691
-0.0547835  0.0170649
-0.0315034  -0.0174493
 0.0315034  -0.0174493
 0.0547835  0.0170649
 0.0607102  0.0158691
    
```

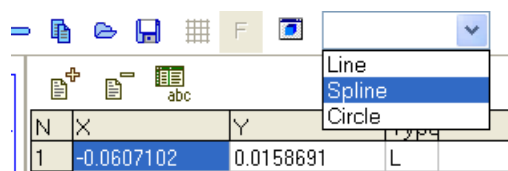



Figure 1.57. Spline interpolation of a curve

The file can be read in the curve editor by  button. A small step size for points along abscissa should be used but not less than one millimeter. It is recommended to use the spline interpolation of selected section or the curve, Figure 1.57.

1.1.1.4.3.4. Template of sprocket

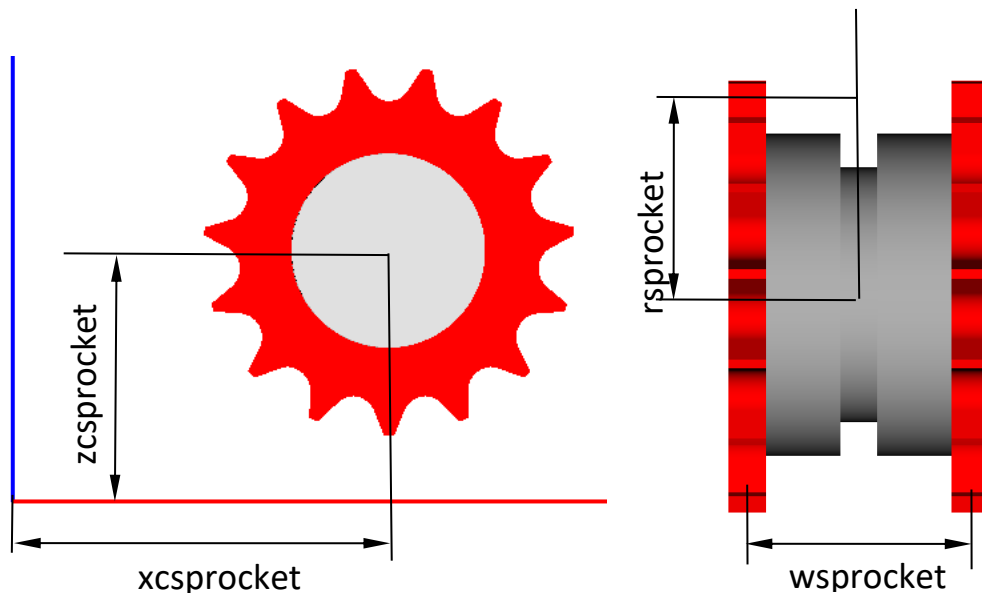

Figure 1.58. Identifiers for geometric parameters of sprocket

1. **Path to the component file:** {UM Data}\Caterpillar\Subsystems\sprocket.dat.
2. **Standard identifiers,** Table 1.14, Figure 1.58.

Table 1.14

Identifier	Comments
<i>wguide</i>	Width of a slot in the wheel for run of track teeth
<i>hguide</i>	Depth of a slot in the wheel for run of track teeth
<i>xcsprocket</i>	Longitudinal coordinate of the sprocket center
<i>zcsprocket</i>	Vertical coordinate of the sprocket center
<i>wsprocket</i>	Sprocket width
<i>rsprocket</i>	Wheel radius on pin centers R_s , Figure 1.51
<i>traction_torque</i>	Standard identifier for traction or brake torque applied to the sprocket

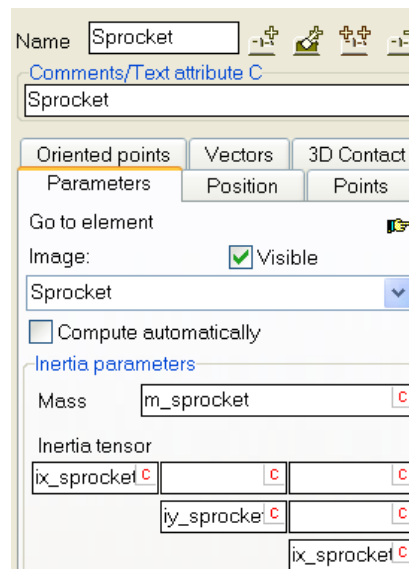

Figure 1.59. Body Sprocket

3. Bodies.

The model contains one body *Sprocket*, marked by the text attribute of C-type: *Sprocket*, Figure 1.59. The attribute is used by the program for identification of the body corresponding to the sprocket. Inertia parameters are presented in Table 1.15.

Table 1.15

Identifiers for inertia parameters

Identifier	Default value	Comments
<i>m_sprocket</i>	100	(kg) Mass
<i>ix_sprocket</i>	15	(kg m ²) Moment of inertia relative to the axis in the wheel plane
<i>iy_sprocket</i>	20	(kg m ²) Moment of inertia relative to the rotation axis

4. Joints.

The model includes one rotational joint *jSprocket* connecting the Sprocket body with *Base0*. By adding the component to the track model, the body *Base0* is automatically replaced by the local hull of the track.

Remark. Sprocket component does not include a tooth profile. The user assigns a profile with the help of the track wizard.

1.1.1.4.4. Track link

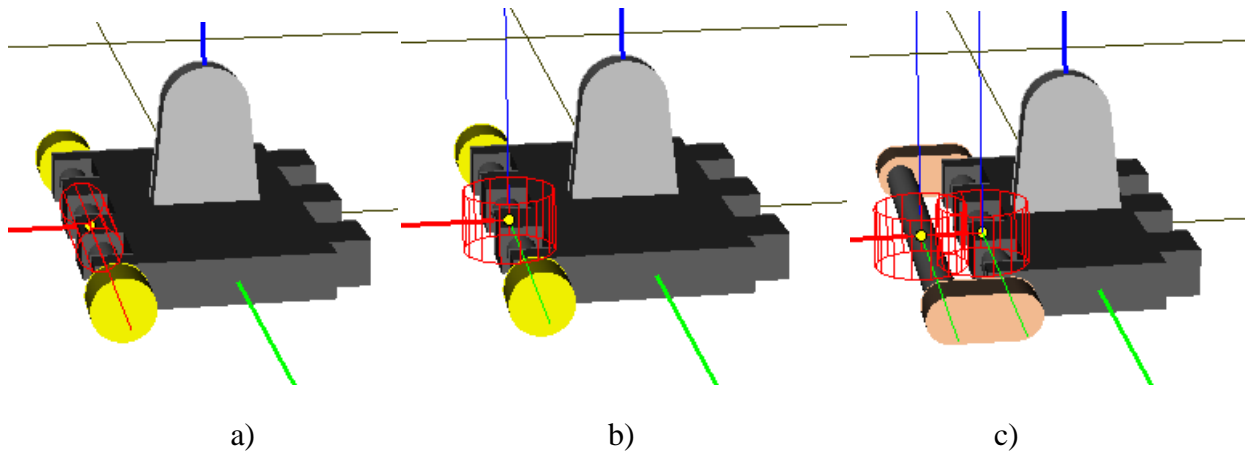

Figure 1.60. Standard models of track links

Three components are delivered as standard ones. The components differ in the joint type:

- **TrackLink_Rigid** with a rigid joint, Figure 1.60a;
- **TrackLink_Bushing** with a flexible joint (bushing), Figure 1.60b;
- **TrackLink_Parallel** with two parallel flexible joints (bushings), Figure 1.60c.

Standard elements

1. **Standard identifiers.** Any component describing a track link must contain the standard identifiers, Table 1.16.

Table 1.16

Identifier	Comments
<i>ltracklink</i>	Track link length
<i>wtracklink</i>	Track link width
<i>htracklink</i>	Track link height
<i>wsprocket</i>	Sprocket width (track link width on pins)

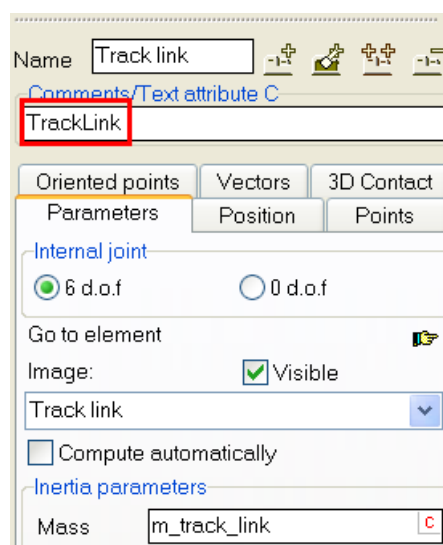

Figure 1.61. Standard text attribute of a track link

2. **Standard element:** a text attribute. The track link body must be marked by the text attribute of C-type: *TrackLink*, Figure 1.61.

1.1.1.4.4.1. Track link with rigid joint

The component models a track link with a rigid rotational joint. The joint model includes both friction and elastic torques, which can be used optionally.

1. **Path to the component file:** {UM Data}\Caterpillar\Subsystems\TrackLink_Rigid.dat.
2. **Bodies.**

The model includes one body *TrackLink*, marked by the text attribute of C-type: *TrackLink*. Inertia parameters are set by identifiers, Table 1.17.

Table 1.17

Inertia parameters

Identifier	Comments
m_track_link	(kg) Mass
ix_track_link, iy_track_link iz_track_link	(kg m ²) Moments of inertia relative to central axis

3. Joints

The model contains two joints:

- an internal joint of body *TrackLink* with six d.o.f., which is removed automatically by adding the link to the track model;
 - rotational joint *jTrack link* connecting the track link with an external body; by adding the link to the track model the next link in the track is automatically assigned as the second body of the joint.
4. **Pin position** (external, internal)

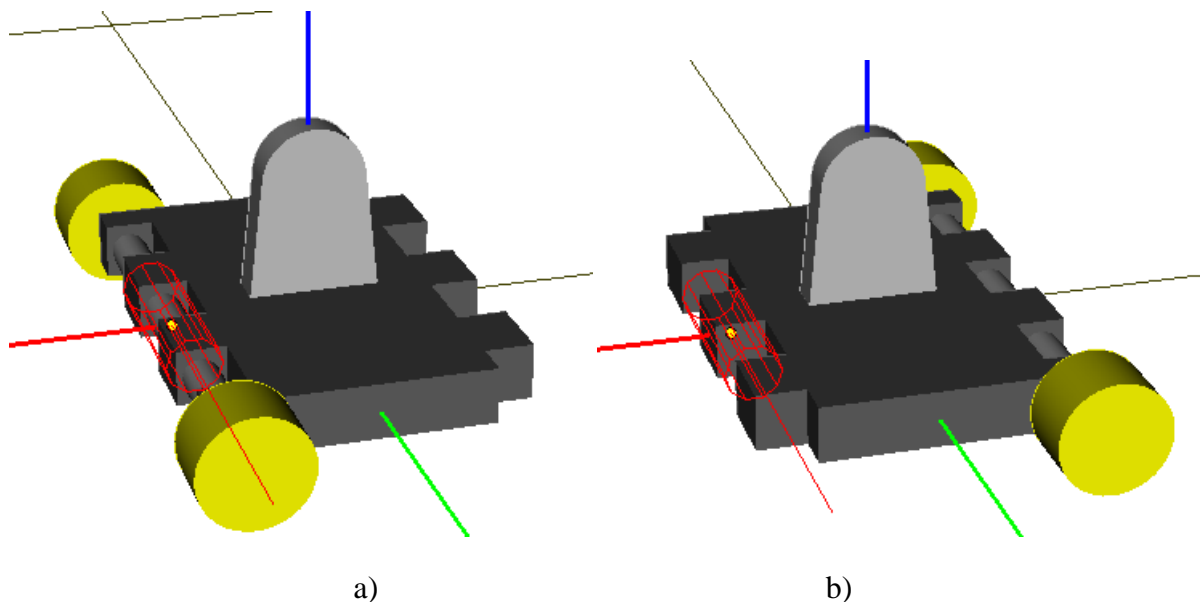

Figure 1.62. Internal (a) and external (b) pin positions

The type of the pin position is specified by the identifier *pin_key*: +1 for the internal and -1 for the external positions, Figure 1.62.

5. Joint force

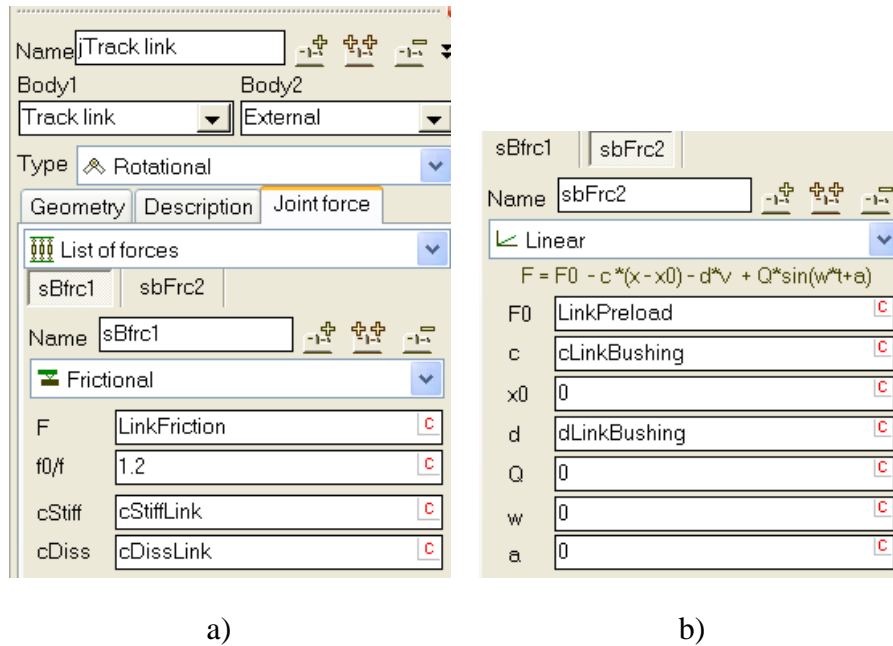

Figure 1.63. Joint torque

The joint torque allows modeling both a friction and a linear viscous-elastic torque in the joint in parallel, Figure 1.63.

Friction torque. The friction torque value is set by the identifier *LinkFriction* (Nm). In the sticking mode, torsion stiffness and damping are set by the identifiers *cStiffLink* (Nm/rad), *cDissLink* (Nms/rad). To remove the friction, numeric values of all three parameters should be set to zero.

Viscous-elastic torque is specified by the stiffness and damping constants *cLinkBushing* (Nm/rad), *dLinkBushing* (Nms/rad). A possible preload torque is set by the identifier *LinkPreload* (Nm) – this is the torque for zero value of the joint coordinate. To remove the linear torque, numeric values of all three parameters should be set to zero.

1.1.1.4.4.2. Track link with flexible joint (bushing)

The component models a track link with a flexible joint or bushing.

Path to the component file:

{UM Data}\Caterpillar\Subsystems\TrackLink_Bushing.dat.

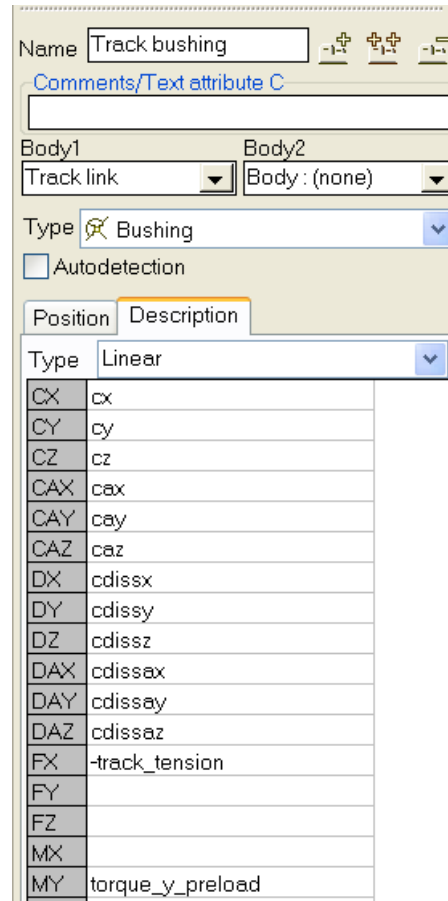

Figure 1.64. Parameters of bushing

The component description is similar to the track link with rigid joint. The main difference is that the rotational joint is replaced by a linear bushing, Figure 1.64.

Stiffness constants for directions of shift and rotation are set by identifiers

cx (N/m, longitudinal stiffness),

cy (N/m, lateral stiffness),

cz (N/m, stiffness by vertical shift)

cax (Nm/rad, torsion stiffness about the longitudinal axis),

cay (Nm/rad, torsion stiffness about the lateral or joint axis),

caz (Nm/rad, torsion stiffness about the vertical axis).

Damping constants are specified with the help of damping ratios β_{ax} for shifts and β_{aa} for rotations. Default values of these parameters are 0.1. Detailed information about the notion of the damping ratio can be found in [Chapter 2](#), Sect. *Methodology of choice of contact parameters*.

For obtaining a desired value of the track tension, a longitudinal force is used parameterized by the standard identifier *track_tension*.

A preload torque, i.e. the torque value for zero rotation about the lateral axis, is set by the identifier *torque_y_preload*.

1.1.1.4.4.3. Track link with two parallel bushings (double pin)

The component is modeled a track link with parallel bushings (double pin). It is assumed that pins of two neighbor links are rigidly connected by a clamp. This construction is considered as an additional rigid body.

Thus, the model description differs from the track link with one bushing by the following elements:

- additional body *Link-Link*,
- joint with six d.o.f. *jBase0_Link-Link*
- additional bushing connecting the body *Link-Link* with an external body (the next link).

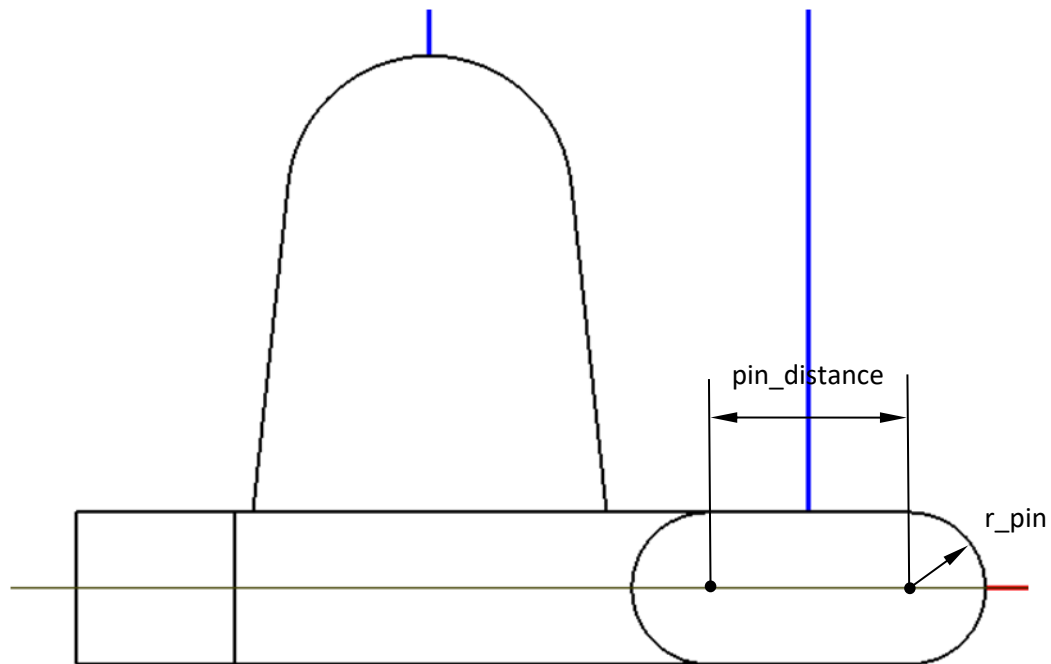

Figure 1.65. Geometrical parameters

The model contains two additional standard identifiers, Figure 1.65:

pin_distance (m) is the distance between pins of neighbor links, L_j in Figure 1.51;

r_pin (m) is the pin radius.

Path to the component file:

{UM Data}\Caterpillar\Subsystems\TrackLink_Parallel.dat.

1.1.1.4.5. Roller

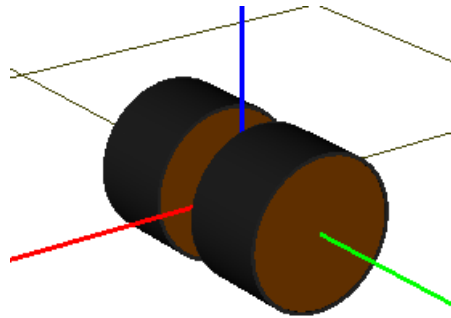

Figure 1.66. Model of a roller

A track can include any number of rollers. In particular, none roller can be presented.

1. **Path to the component file:** {UM Data}\Caterpillar\Subsystems\roller.dat.
2. **Standard identifiers,** Table 1.18.

Table 1.18

Identifier	Comments
<i>wguide</i>	Width of a slot in the roller for run of track teeth
<i>hguide</i>	Depth of a slot in the roller for run of track teeth
<i>rroller</i>	Roller radius
<i>wroller</i>	Roller width

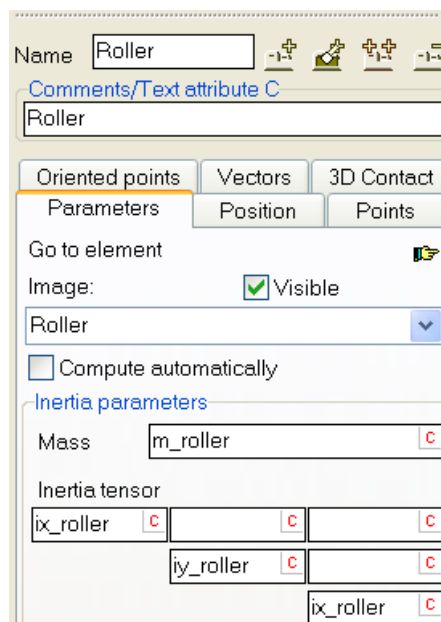

Figure 1.67. Roller body parameters

3. Bodies.

The model contains one body *Roller*, marked by the text attribute of the C-type: *Roller*, Figure 1.67. This attribute is used for identification of the roller by the program. Inertia parameters are presented in Table 1.19.

Table 1.19

Inertia parameters

Identifier	Default value	Comments
<i>m_roller</i>	20	(kg) Mass
<i>ix_roller</i>	2	(kg m ²) Moment of inertia relative to the axis in the roller plane
<i>iy_roller</i>	1	(kg m ²) Moment of inertia relative to the rotation axis

4. Joints.

The model included one rotational joint *jRoller* connecting the roller with *Base0*. By adding the component to the track model, the body *Base0* is automatically replaced by the local hull of the track.

1.1.2. Development of user's components

In this section, we consider an example of development of a new component.

Note that often new components are obtained as a result of modification of existing ones. For instance, the user can change images of elements in the components.

1.1.2.1. Development of a torsion bogie with three wheels

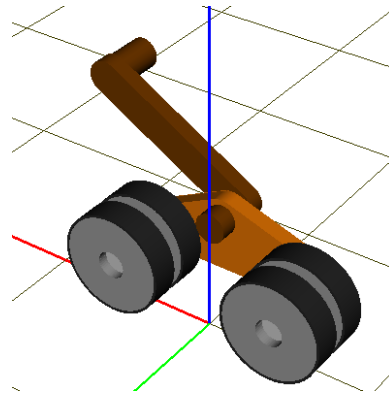





Figure 1.68. An analogue of the developing bogie

1. Selection of an analogue and creation of a file with new component.

Consider a torsion bogie with two wheels as an analogue of a new component, Figure 1.68, Sect. 1.1.1.4.1.5. "*Torsion two-wheel bogie*", p. 1-27. Our goal is to add the third road wheel connected with the frame by a rotational joint.

- Run **UM Input**
- Create a new UM object by the  button on the tool panel or by the **File | New object** menu command.
- Read the file `{UM Data}\Caterpillar\Subsystems\bogie_2wheel_1arm.dat` by the  button on the tool panel or by the **Edit | Read from file...** menu command.

The program adds to the object a subsystem with the bogie shown in Figure 1.68 as well as the list of selected identifiers.

- Save the object to file as a new component in any directory, for example `{UM Data}\Caterpillar\Subsystems\bogie_3wheel_1arm.dat` by the  button or by the **File | Save as component** command.

Note that *the name of the file* will be accepted as *the name of the component*. File extension must be *.dat.

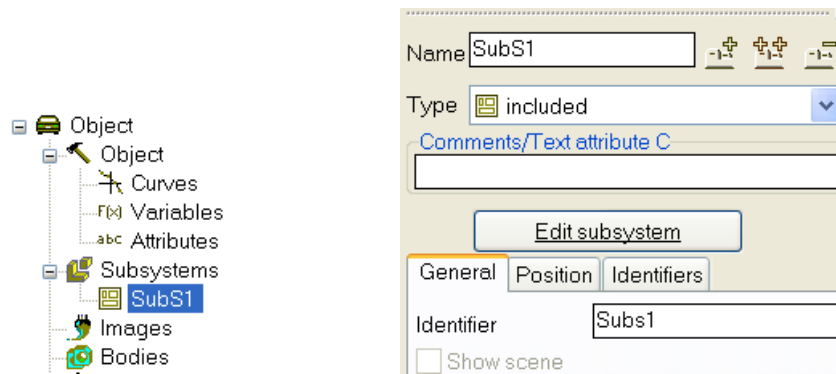

Figure 1.69. Component editing

2. Modification of the bogie model

- Select the subsystem *Subs1* in the list of elements and start its editing by the **Edit** button in the inspector, Figure 1.69. A new window with the bogie description is opened.

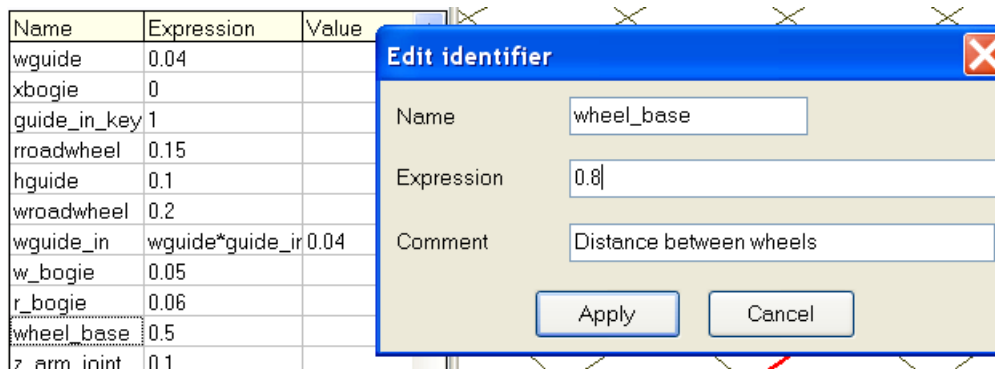

Figure 1.70. Change of bogie base

- Double click in the identifier *wheel_base* and change its value to 0.8, Figure 1.70.

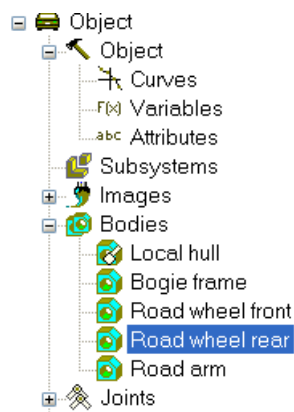

Figure 1.71. Selection of a body

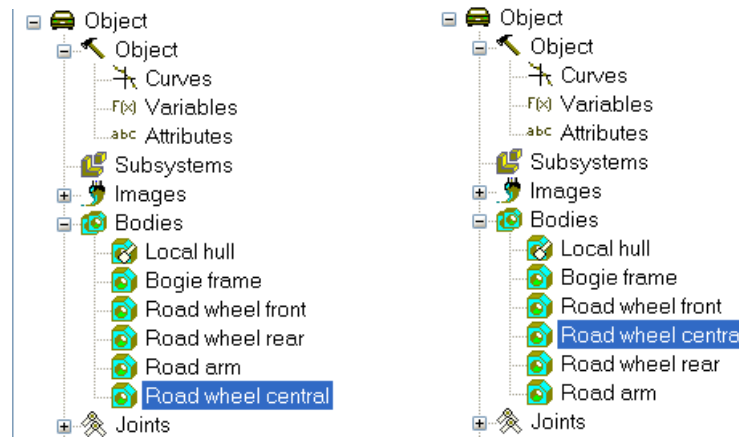



Figure 1.72. Change of body position in the list

- Select the *Road wheel rear* body, Figure 1.71, copy it by the  button and rename to *Road wheel central* (do not forget to press Enter after changing the name). Change the body position in the list by the mouse, Figure 1.72.

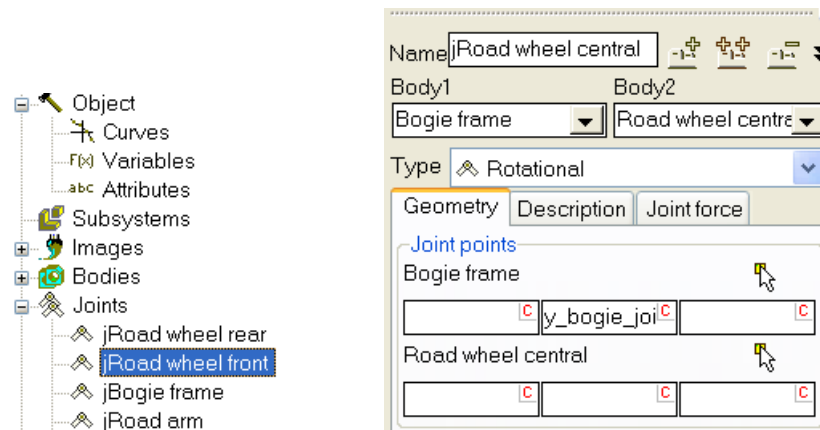

Figure 1.73. Selection of a joint and parameters of new joint

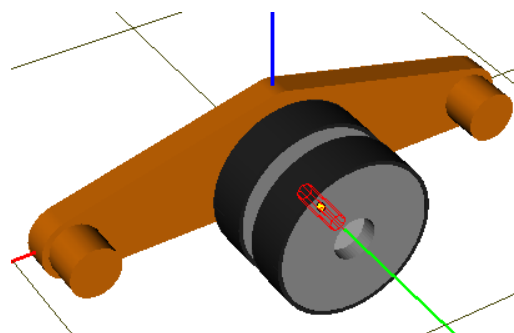



Figure 1.74. New kinematic pair

- Select the *jRoad wheel rear* joint, Figure 1.74, and copy it by the  button. Rename the joint as *jRoad wheel central* and press Enter. Assign the second body *Road wheel central*. Set zero value of the longitudinal joint coordinate for body *Bogie frame*, Figure 1.73 right, Figure 1.74.

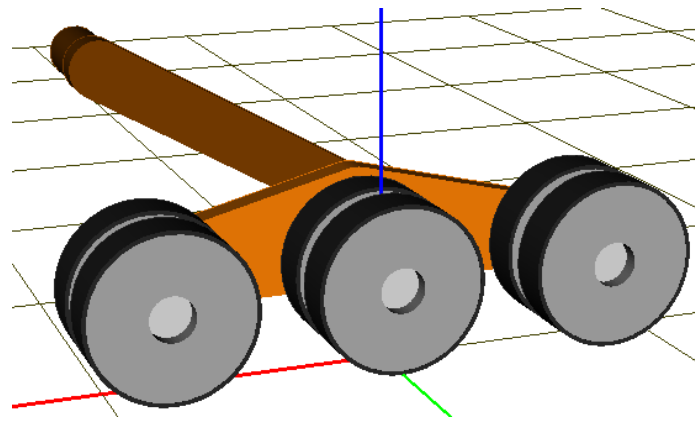

Figure 1.75. Final view

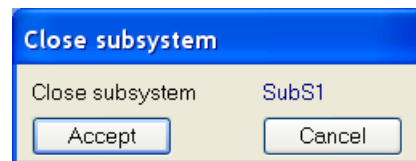



Figure 1.76. Closing of subsystem description

- The model is ready, Figure 1.75. Accept modifications in the subsystem by the corresponding button in the **Close subsystem** window, Figure 1.76.
- Save the modified model by the  button or by the **File | Save as component...** menu command.
- Close the model window without saving.

After development of the model, it must be registered (Sect. 1.1.3. "*Registration of new TV components*", p. 1-66).

1.1.3. Registration of new TV components

New components of TV elements should be registered before they can be used by development of a track model.

The following components can be registered in the current UM version, Sect. 1.1.1.4.2. "Idler and tension device", p. 1-31:

- suspension unit
- idler with tension device
- track link

The following steps are necessary for the registration.

1. Open **UM Input**. If it is already open, close all UM objects.

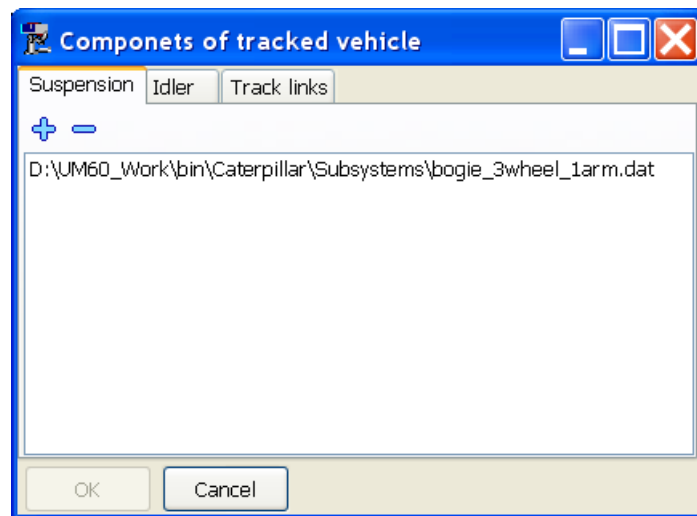

Figure 1.77. Tool for registration of TV components

2. Open the "Components of track vehicle" window by the **Tools | Components of track vehicle...** command, Figure 1.77. If the command is not enabled, verify whether all objects are closed.
3. Select a necessary tab in the window, e.g. **Suspension**, and open a file with the component by the **+** button.
4. To exclude the component from the list, use the **-** button.
5. Use the **Accept** or **Cancel** buttons to update the registry or to skip modifications.

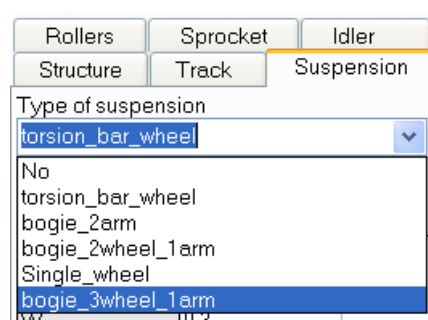

Figure 1.78. List of standard and registered suspension units

After registration, the components become available in the corresponding list of components of the wizard of track model, Figure 1.78.

Remark. Components are registered on the local machine. To use it on another computer, the component must be registered there in the same manner.

1.1.4. Development of TV model

A special tool named 'Wizard of track' is used for automatic generation of a track model. Consider detailed a sequence of steps, which are necessary for generation of a TV.

We will use some parameters of a Russian high-speed crawler transporter.

1.1.4.1. Preparing step

If the model cannot be developed with use of standard components, the user should create own components and register them. Three types of TV parts are available for these purposes:

- suspension units
- idler with tension device
- track link

The user can change images in the standard components, add new force elements and modify existing ones.

It is necessary to create files with a sprocket tooth and, if necessary, a pin profile, Sect. 1.1.1.4.3.2. "Automatic generator of sprocket tooth profiles", p. 1-45, Sect. 1.1.1.4.3.3. "Creation of profile by curve editor", p. 1-48.

1.1.4.2. Adding a track subsystem

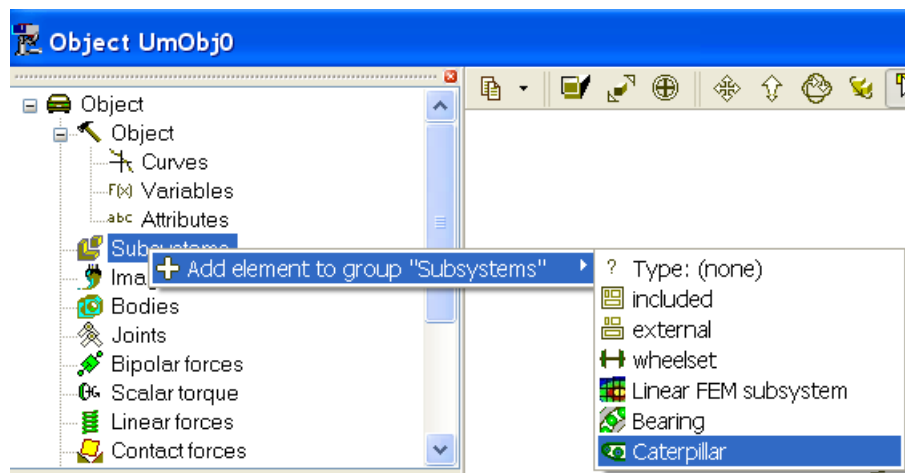

Figure 1.79. Adding a subsystem of type 'Caterpillar'

1. Create a new UM object in **UM Input**.
2. Add a **Caterpillar** subsystem:
 - select the **Subsystems** item in the list of elements
 - click the right mouse button and select the **Add element to group "Subsystems" | Caterpillar** command, Figure 1.79.

As a result, a **Wizard of track** appears in the object inspector. The following tabs are available on the **Parameters** sheet

- Structure
- Suspension
- Sprocket
- Idler
- Rollers
- Track

1.1.4.3. Track structure

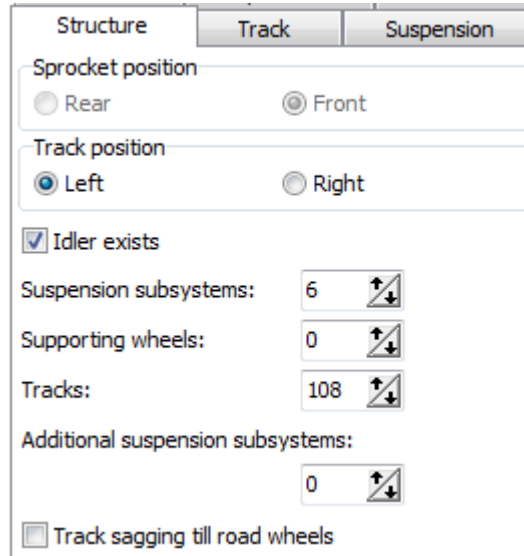

Figure 1.80. Parameters of track structure

The following parameters should be set on the **Structure** tab, Figure 1.80:

- position of the track **Left/Right**
- number of suspension units (must be positive)
- number of rollers (can be zero)
- number of track links
- Number of additional suspension subsystems is used for generation of track with several different types of suspensions, Figure 1.81.

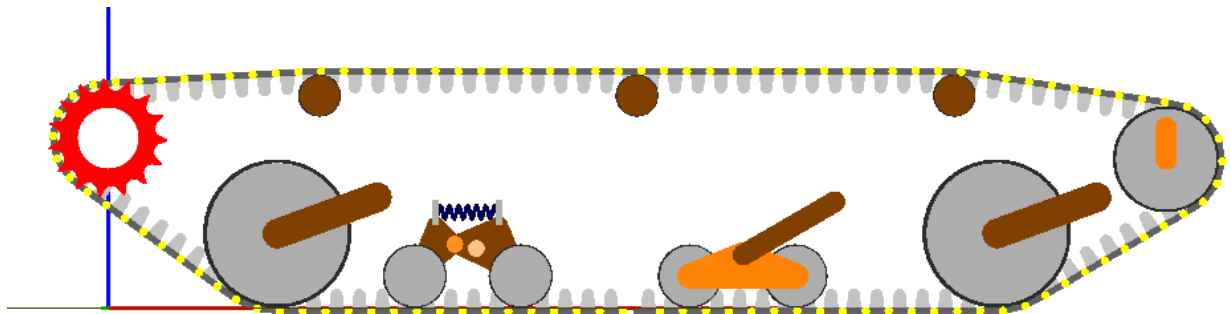

Figure 1.81. Example of a track with three different types of suspensions (for illustration of possibilities only)

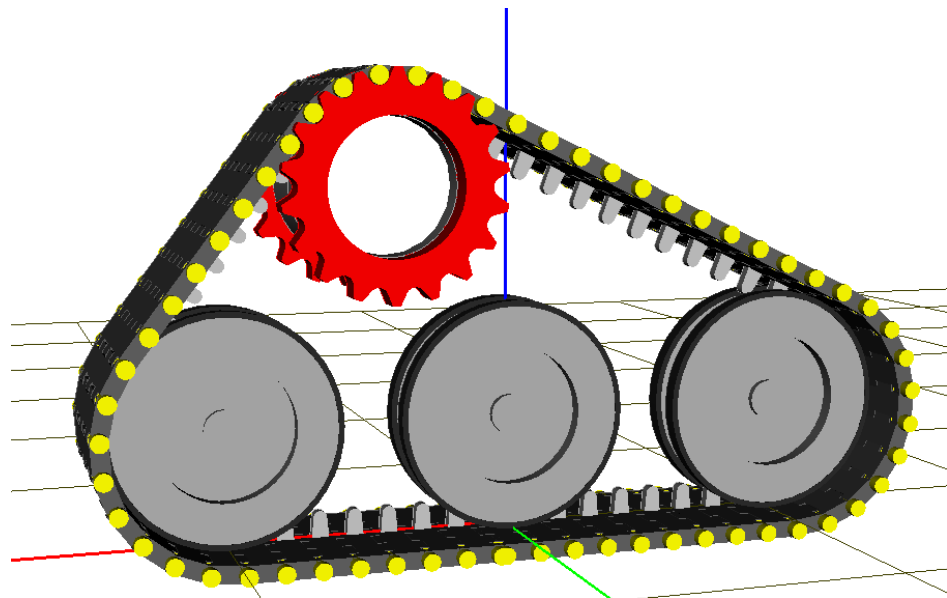

Figure 1.82. Example of a track without an idler

An idler is removed from a track if the **Idler exists** option is unchecked, Figure 1.82.

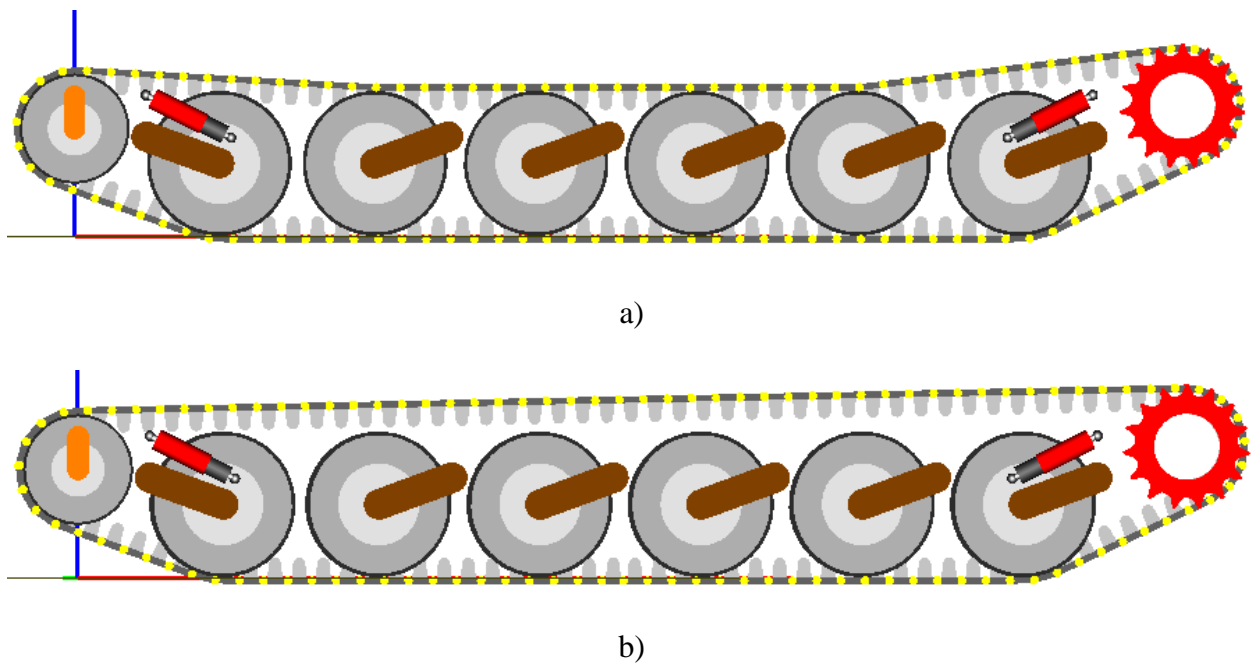

Figure 1.83. Track without supporting wheels with checked (a) and unchecked (b) option 'Track sagging till road wheels'

The **Track sagging till road wheels** option is used if no supporting wheels are presented in the track, Figure 1.83.

1.1.4.4. Suspension

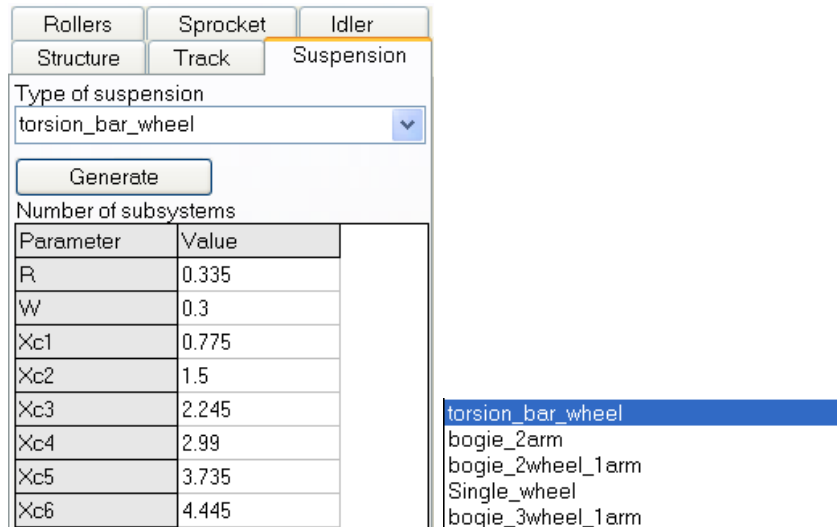

Figure 1.84. Suspension parameters

Suspension tab.

1. Select the type of suspension from the drop-down list
2. Set geometrical parameters of the suspension in meters, Sect. 1.1.1.4.1.1. *"Standard elements and identifiers of suspension subsystems"*, p. 1-10, Table 1.1
 - R is the radius or road wheels corresponding to the standard identifier *rroadwheel*
 - W is the width of road wheels corresponding to the standard identifier *wroadwheel*
 - Xc1... are the longitudinal coordinates specifying positions of suspension units; number of coordinates is equal to the number of the units in the **Structure** tab; the coordinate values are automatically assigned to the standard identifiers *xbogie* in each of the subsystems.

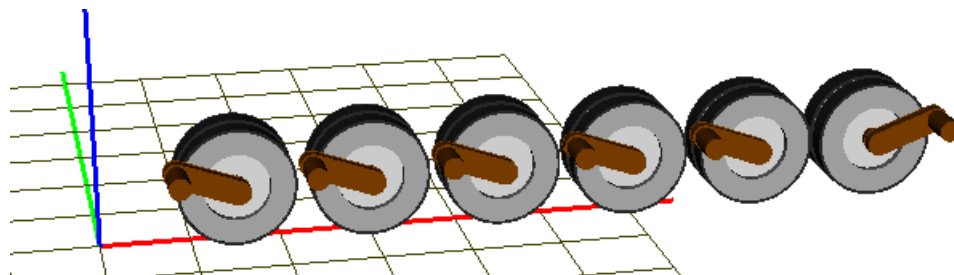

Figure 1.85. Generated suspension

- Click on the **Generate** button to create the suspension model; the suspension image appears in the animation window, Figure 1.85.
- Use the **Identifiers | Suspension** tab for modification of numerical values of selected identifiers
- It necessary, parameters of the subsystem can be changed. After changing, click the **Generate** button.

1.1.4.5. Sprocket

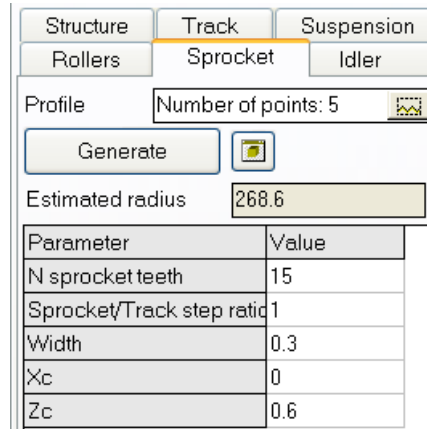

Figure 1.86. Sprocket parameters

Tab Sprocket

- Assign a tooth profiles with the built-in curve editor:
 - open the editor by the button
 - read a preliminary created file with profile by the button.
- Set the number of teeth, sprocket/track step ratio t_w/t_t as well as geometric parameters, see Table 1.14:
 - Width** parameter corresponds to the *wsprocket* identifier
 - Xc, Zc are the longitudinal and vertical coordinates corresponding to the identifiers *xcsprocket*, *zcsprocket*
- The button is used for the preliminary view of the sprocket.

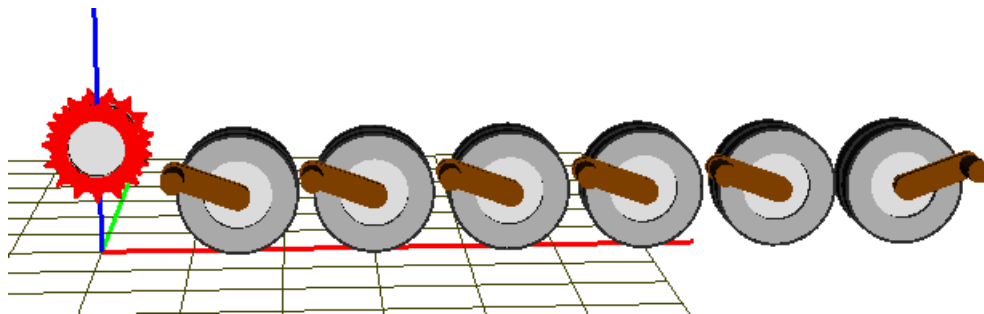

Figure 1.87. Adding sprocket to model

- The **Generate** button adds the sprocket to the model, Figure 1.87.

Remark. Sprocket radius is computed automatically at the last step of development of a track model, when all geometric parameters of the model are defined.

1.1.4.6. Idler

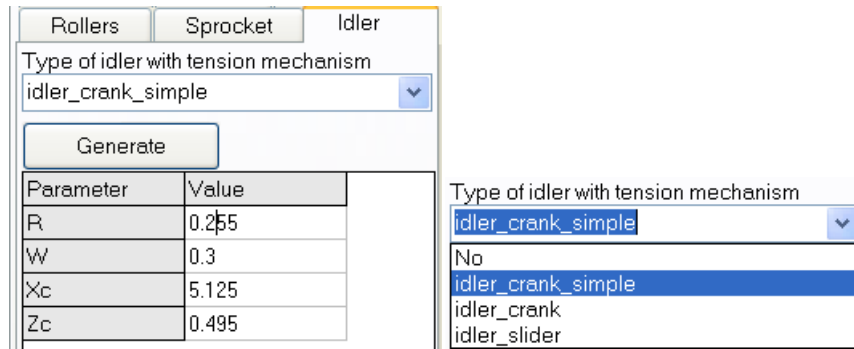

Figure 1.88. Idler parameters

Idler tab, Figure 1.88

1. Select a type of the tension mechanism from the drop-down box.
2. Set geometrical parameters of the idler in meters, Table 1.10.
 - R is the idler radius corresponding to the standard identifier *ridler*
 - W is the idler width, the standard identifier *widler*
 - Xc, Zc are the longitudinal and vertical coordinates of the idler center, the standard identifiers *xcidler*, *zcidler*.
3. The **Generate** button adds the idler to the model, Figure 1.89.
4. Set numerical values of the tension device parameters.

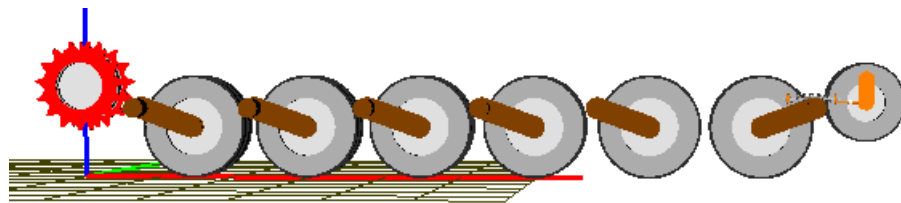

Figure 1.89. Adding idler to model

1.1.4.7. Rollers

Parameter	Value
R	0.12
W	0.3
Xc1	1.9
Zc1	1.05
Xc2	4.9
Zc2	1.05

Figure 1.90. Parameters of rollers

Rollers tab, Figure 1.90

1. Set geometrical parameters for rollers in meters, Table 1.10.
 - R is the roller radius, the standard identifier *rroller*
 - W is the roller width, the standard identifier *wroller*
 - Xc..., Zc... are the longitudinal and vertical coordinates of roller centers.
2. The **Generate** button adds rollers to the model.

1.1.4.8. Track

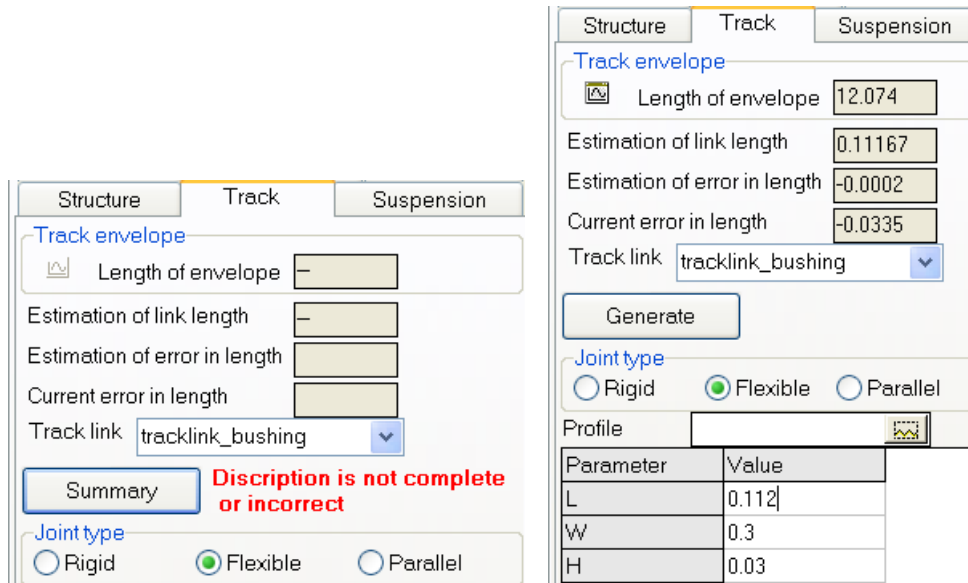



Figure 1.91. Track tab in case of non-complete and complete state

Model of the track consisting of given number of links is created on the **Track** tab, Figure 1.91. The track can be generated only if all other elements are correctly described by the user and added to the model: suspension units, sprocket, idler, rollers. According to the geometrical parameters including coordinates of wheel centers and radii, UM compute an enveloping curve for the track chain. The estimated length of this curve is set in the **Length of envelope** box. By the  button, the user may get a window with the envelope image, Figure 1.92.

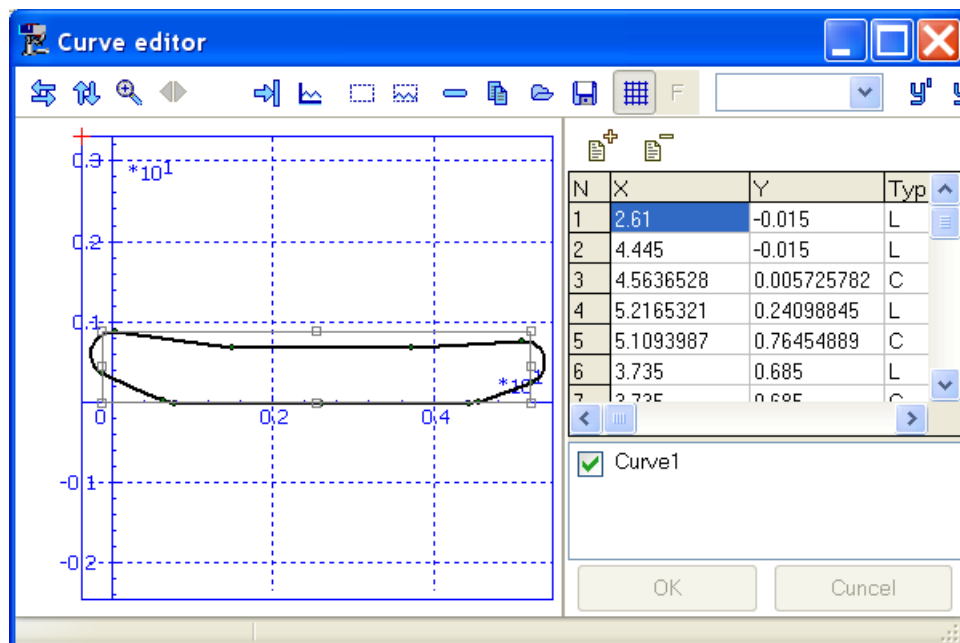

Figure 1.92. Track curve

If specification of track elements is not complete (e.g. if the idler is not added to the model), and UM cannot generate the enveloping curve, the message ‘Description is not complete or incorrect’ is visible. The **Summary** button displays comments to the errors.

If all geometrical parameters are specified but the difference between the estimated L_{est} and the real $L=n_{link}L_{link}$ lengths (n_{link} , L_{link} are the number and length of links) exceed the length of a track link (‘Current error in length’), the track cannot be generated as well. The user should correct some geometrical parameters, e.g. coordinates of the idler center, or change the number of links to avoid the lack or redundancy of links in the chain.

The program computes a recommended length of the track link (‘Estimation of track length’), which matches the track curve. If the recommended length of link differs from the specified one on a fraction of millimeter like in Figure 1.91, right, it is desirable to correct the length L to improve the closure condition of the track.

If all geometrical parameters including the track length are correct, the **Generate** button becomes available, and the user may add the links to the track model.

The following steps are necessary.

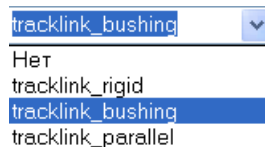

1. Choose the track link type from the list.
2. Set the joint type if the link type differs from the three standard ones.
3. Specify the pin profile with the curve editor by the  button.
4. Set the length, width and height of the link (L , W , H parameters, m).
5. Add links by the **Generate** button, Figure 1.93.

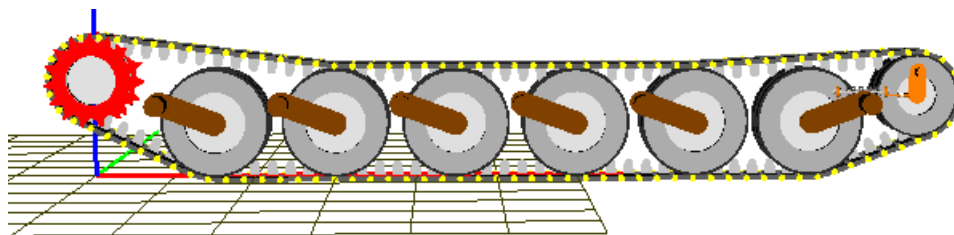
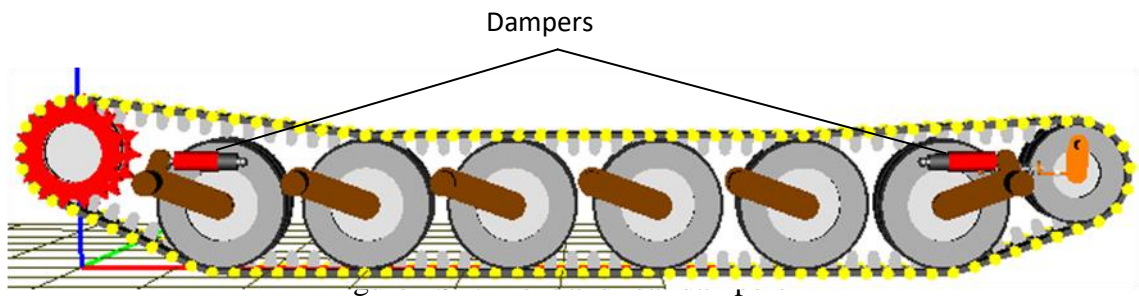

Figure 1.93. Track model

1.1.4.9. Completion of track model. Adding dampers

If necessary, dampers (shock absorbers), stops and other force elements can be added to the track model, Figure 1.94. Standard tools for description of force elements are used for this purpose.



Dampers can be modeled by bipolar force elements. An example of damper characteristics is shown in Figure 1.95. To create such a model, the user should set

- bodies connected by the damper;
- coordinates of attachment points in SC of each of two bodies;
- type of force element: **Points (numeric)**;
- velocity (v) as abscissa type;
- type of characteristic: compression positive (i.e. the positive velocity on the plot corresponds to the compression of the element);

force vs. velocity points in the order corresponding to the growth of the velocity; units are N for force and m/s for velocity.

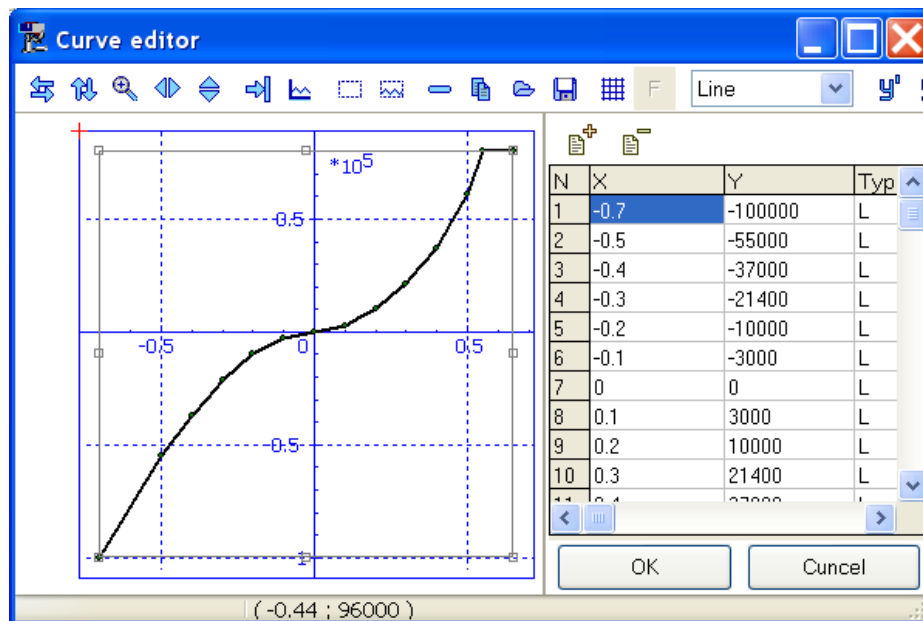
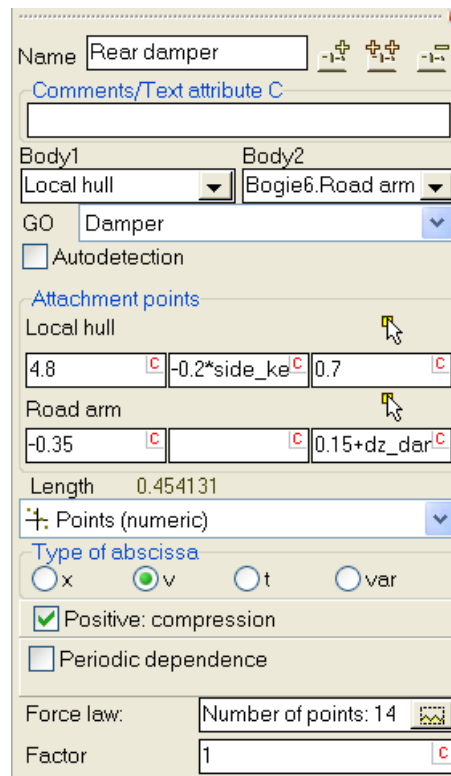

Figure 1.95. Damper as a bipolar force element

It is recommended to use the **Frictional** type of bipolar force for modeling frictional dampers.

See [Chapter 2](#) of the user's manual for additional information about modeling of force elements in UM.

1.1.5. Finalization of TV model

In the previous section we described the development of a track model. Here we consider a method for finalization of a complete TV model, which requires adding a hull, a second track, connecting tracks with the hull and, if necessary, adding transmission elements.

1.1.5.1. Adding a hull

To add a hull to the model of TV, make the following steps.

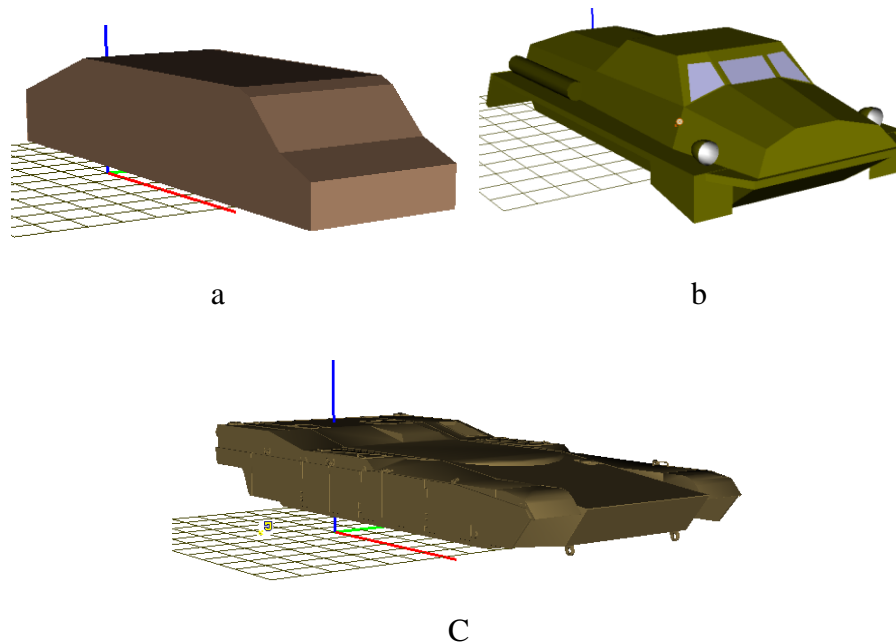

Figure 1.96. Schematic (a), more detailed (b) and imported from CAD hull images

1. Create a graphic object for the hull image. The image can be both simplified and more realistic or imported from CAD software, Figure 1.96. The image is not important for simulation results but it influences the quality of visualization of the TV model.

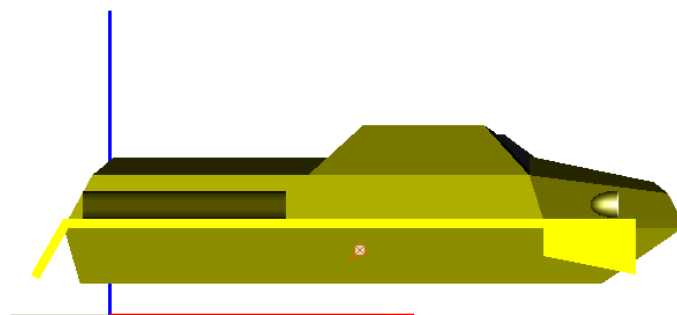

Figure 1.97. Hull-fixed SC coinciding with SC0 for zero values of coordinates

2. Add a body corresponding to the hull to the TV model, assign the image. Set inertia parameters (mass, moments of inertia relative to the SC with the origin in the hull center of mass,

coordinates of the center of mass). It is recommended to choose the hull-fixed system of coordinates in such a way that it coincides with SC0 for zero values of coordinates, Figure 1.97. The image should be shift according to this choice.

Remark 1. Please note that moments of inertia of bodies are specified in the central SC (i.e. the origin is located in the center of gravity of the body) which axes are parallel to the axes of the body-fixed SC.

Remark 2. For internal identification of the hull by the program it is recommended to use the standard name Hull or a text attribute with the same name, see Sect. 1.1.6.2.8. "Steps after adding transmission model", p. 1-94.

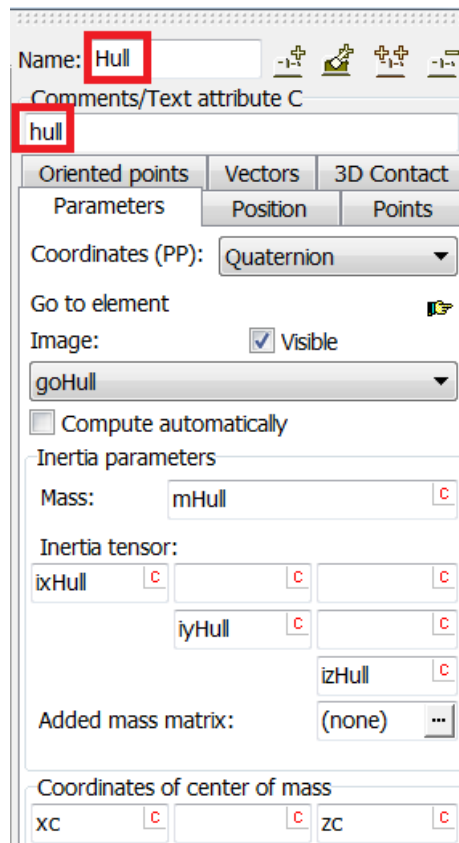

Figure 1.98. Inertia parameters of a hull

If inertia parameters of the hull are not known exactly or/and can be modified, they must be parameterized, Figure 1.98.

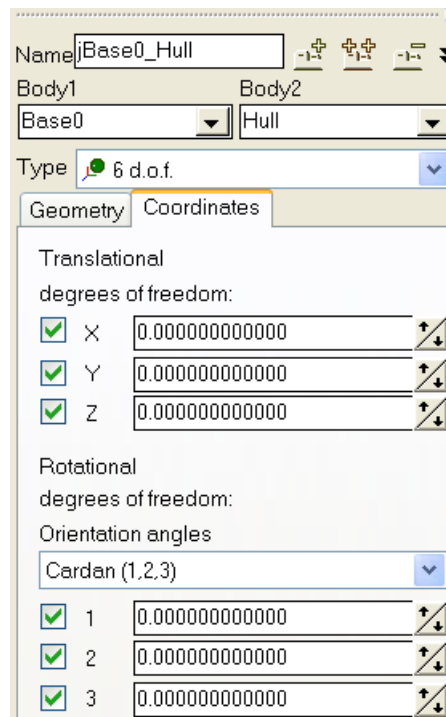

Figure 1.99. Joint introducing six degrees of freedom of a hull relative to Base0

3. Add a joint with six d.o.f. specifying coordinates of the hull relative to SC0 (*Base0*), Figure 1.99. The first body in this joint must be *Base0*, the second one is the hull.

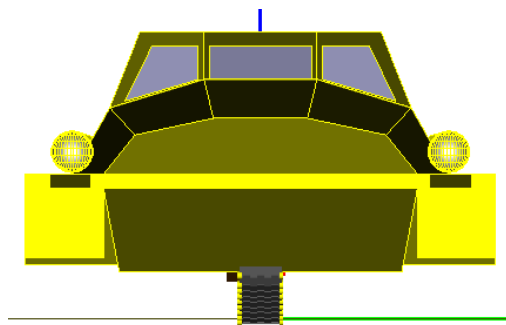

Figure 1.100. Model of TV with the hull

As a result, the hull is added to the model of the TV but it is still not connected with the track. Moreover, the TV contains so far only one (left) track located in the middle of the hull, Figure 1.100.

1.1.5.2. Connection of track with hull

To connect joint and force elements described in the track model with the hull of the TV, it is necessary to fix the *local hull* of the track with the hull of the TV, Sect. 1.1.1.4.1.1. "*Standard elements and identifiers of suspension subsystems*", p. 1-10. As we have mentioned, the joints and force elements are firstly connected with the local hull of the track, and the latest step will connect them directly with the hull of TV.

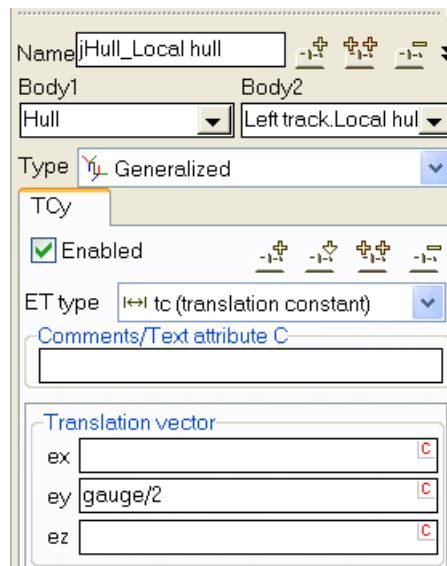

Figure 1.101. Joint rigidly connecting the local hull of track with the hull of TV

Fixing the local hull relative to the hull of TV is made by a joint with zero number of d.o.f., Figure 1.101:

- add a joint;
- assign the hull as the first body and the local hull as the second one;
- set joint type: **Generalized**;
- add one elementary transformation and set its type tc (translation constant);
- set lateral shift of the track relative to the hull (a half of the gauge) in the *ey* box, Figure 1.101.

The result is shown in Figure 1.102.

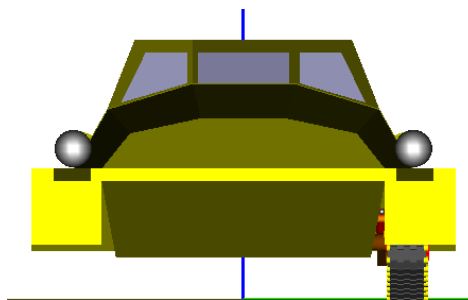



Figure 1.102. Model with one track

It is recommended using the *gauge* identifier for the parameterization of the TV gauge value, see Sect. 1.1.6.2.8. "Steps after adding transmission model", p. 1-94.

1.1.5.3. Adding the second track

To complete the TV model, it is necessary to add the second track:

- open the first track in the inspector;
- copy the subsystem by the  button;

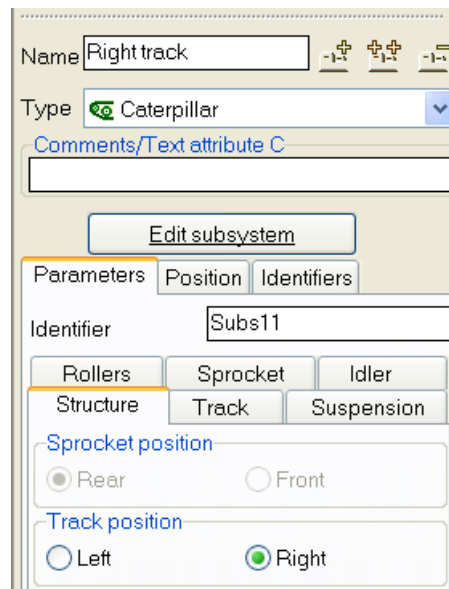

Figure 1.103. Right track

- set track position **Right**, Figure 1.103;
- copy the joint fixing the local hull of the left track with the hull of TV;

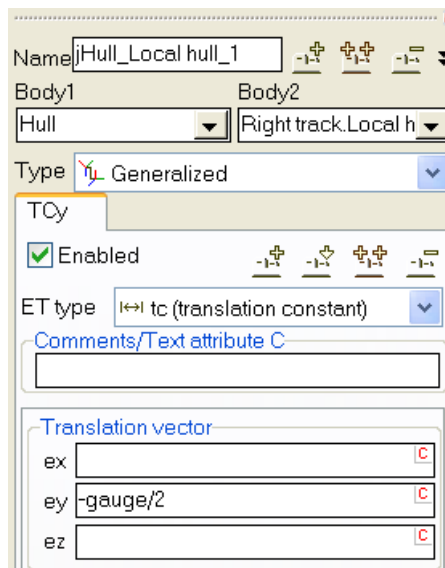

Figure 1.104. Joint rigidly connecting the local hull of the right track with the hull of TV

- set the local hull of the right track as the second body;
- change sign of the lateral shift in the **ey** box, Figure 1.104.

1.1.5.4. Correction of vertical TV position

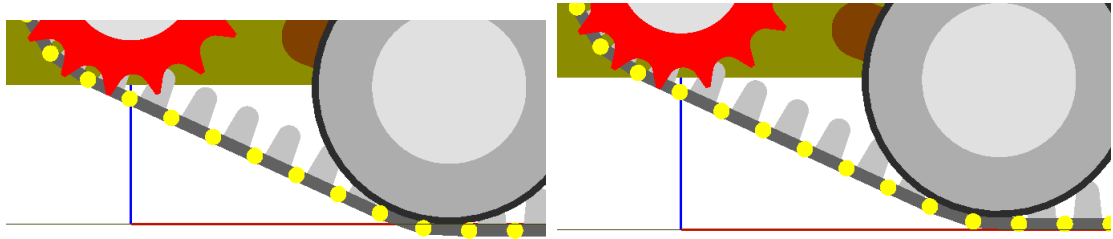

Figure 1.105. Shift the model upwards

To avoid intensive transient processes by simulation, it is recommended to shift the TV model upwards on the link height, Figure 1.105.

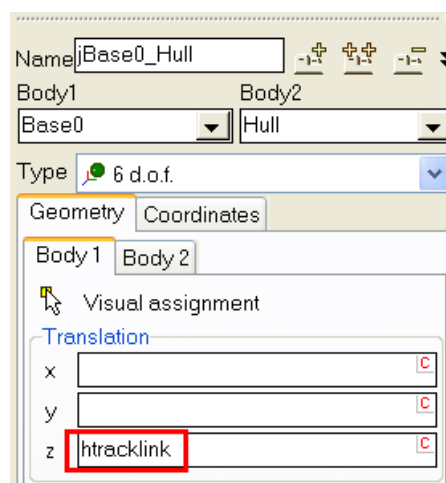

Figure 1.106. Vertical shift of TV model

To shift the model upwards, open the joint specifying coordinates of the TV hull relative to the SC0 and set the vertical coordinate in the **Geometry | Body1** tab, Figure 1.106.

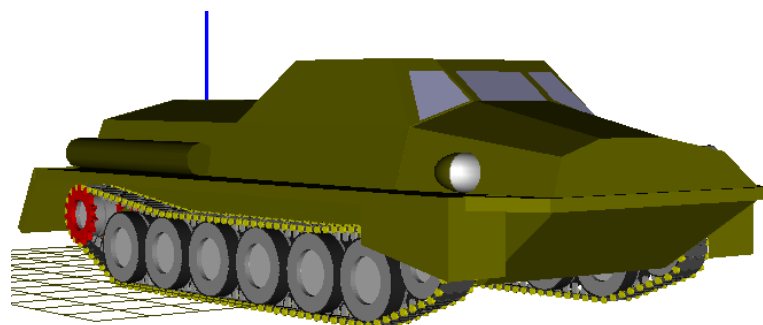

Figure 1.107. Model of TV

The model of TV is ready, Figure 1.107. Using this model, the user can analyze loading the suspension and ride comfort, as well as optimize suspension parameters, etc.

1.1.6. Transmission and steering system

The model of transmission includes an internal combustion engine (ICE), powertrain and steering mechanism. Elements of transmission are detailed described in [Chapter 22](#) "UM Driveline". Here we consider database of TV transmissions, which differ on the steering system.

1.1.6.1. Adding transmission from database

Database of TV transmissions is located in the directory {UM Data}\Caterpillar\Driveline and includes files listed in Table 1.20.

Table 1.20

Menu item	File name	Model description
Clutch-brake steering	Clutch – Brake.dat	1.1.6.3
Planetary steering	Planetary steering.dat	1.1.6.4
Controlled differential steering	Controlled differential steering.dat	1.1.6.5
"Maybach" double differential steering	Maybach double differential.dat	1.1.6.6
Double differential steering	Double differential steering.dat	1.1.6.7
Double differential steering SU	Double differential steering SU.dat	1.1.6.8
Triple differential steering	Triple differential steering.dat	1.1.6.9
Double differential steering HSD ^{*)}	Double differential steering HSD.dat	1.1.6.10

^{*)} Hydrostatic drive

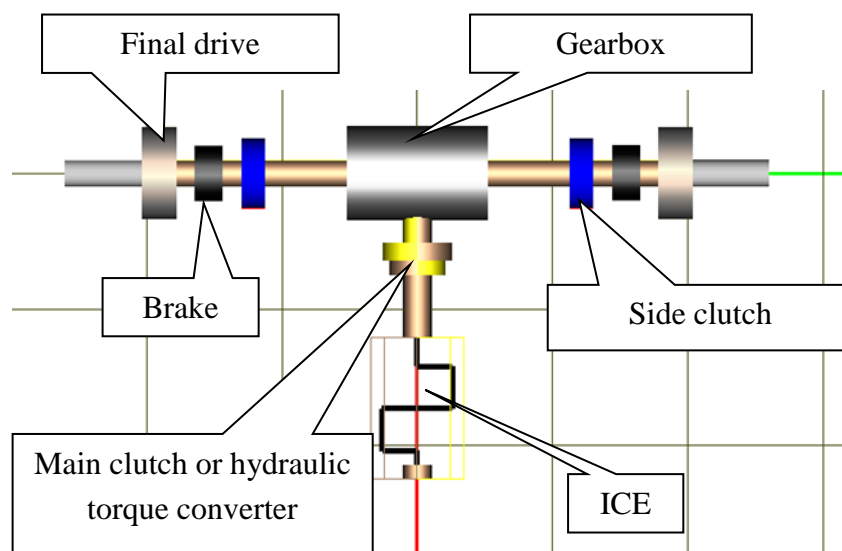

Figure 1.108. Transmission with Clutch-Brake steering mechanism

The **Tools | Add transmission mechanism** menu item is used to add a transmission to the TV model, Figure 1.109. After selection of the desired transmission, the model will be added to the TV model and several steps of TV-transmission coupling will be done automatically. List of transmission models and the corresponding data files are collected in Table 1.20.

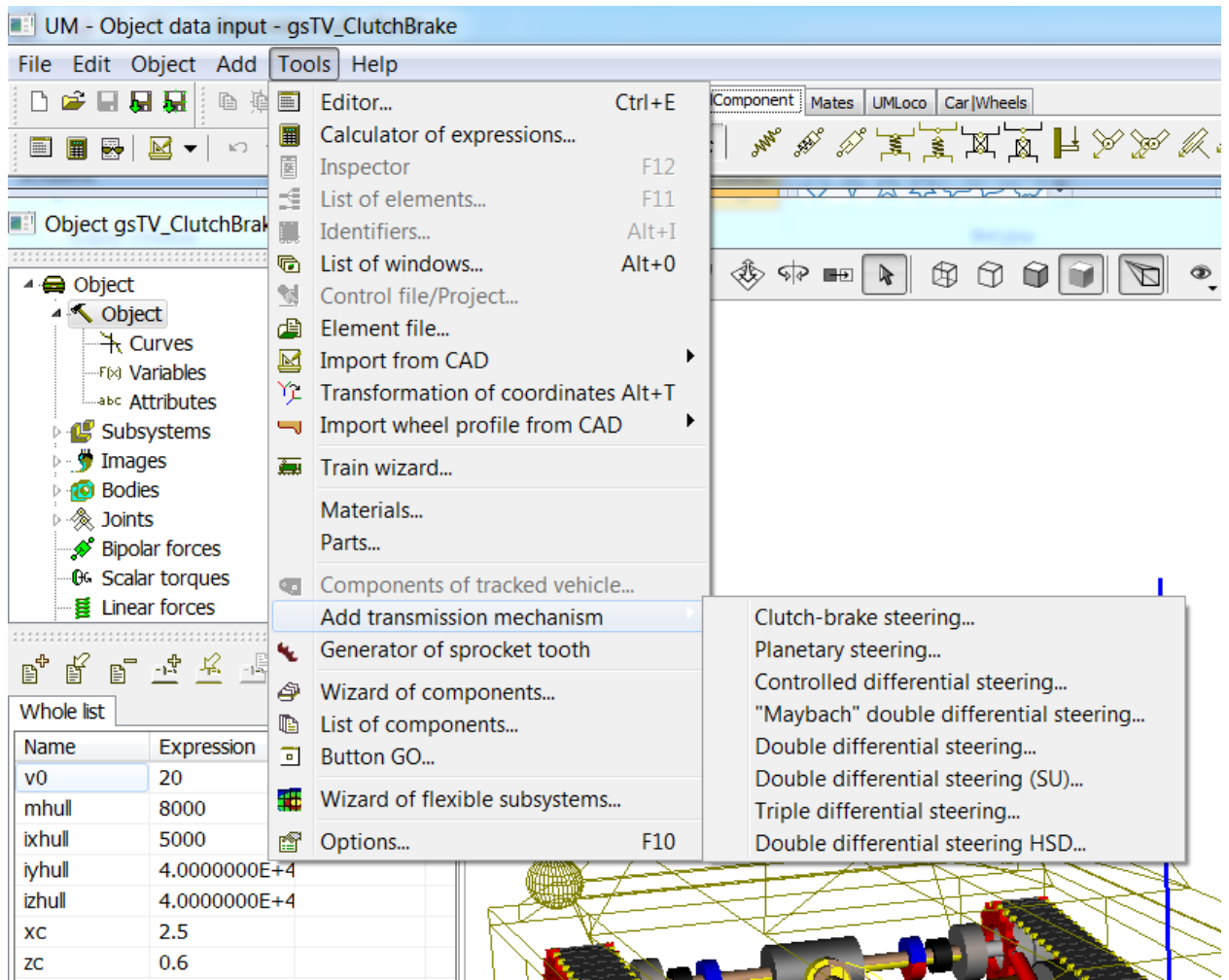

Figure 1.109. Adding a transmission to the TV model

1.1.6.2. Common element of standard transmission models

We describe here elements of transmissions presented in every of the standard UM models. Consider the file Clutch - Brake.dat as an example.

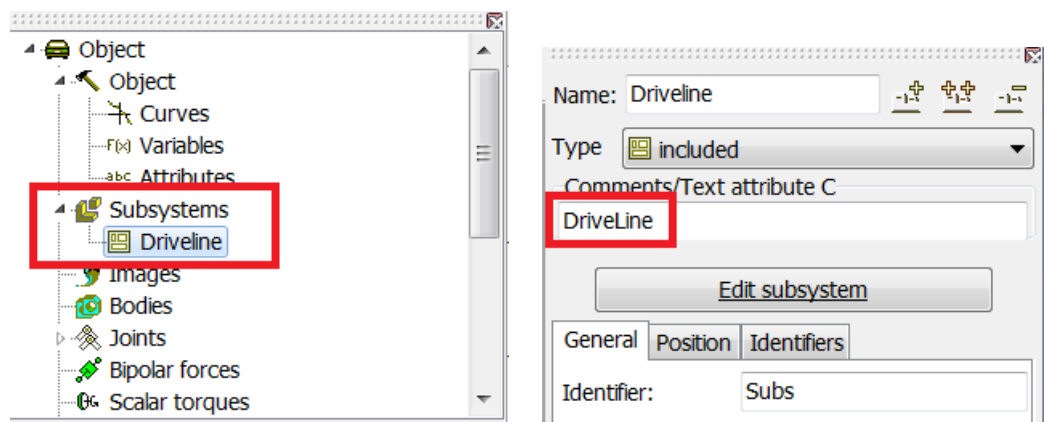

Figure 1.110. Subsystem with model of transmission

The file contains an object which includes one subsystem representing the transmission model. The 'driveline' text attribute identifies the transmission, Figure 1.110.

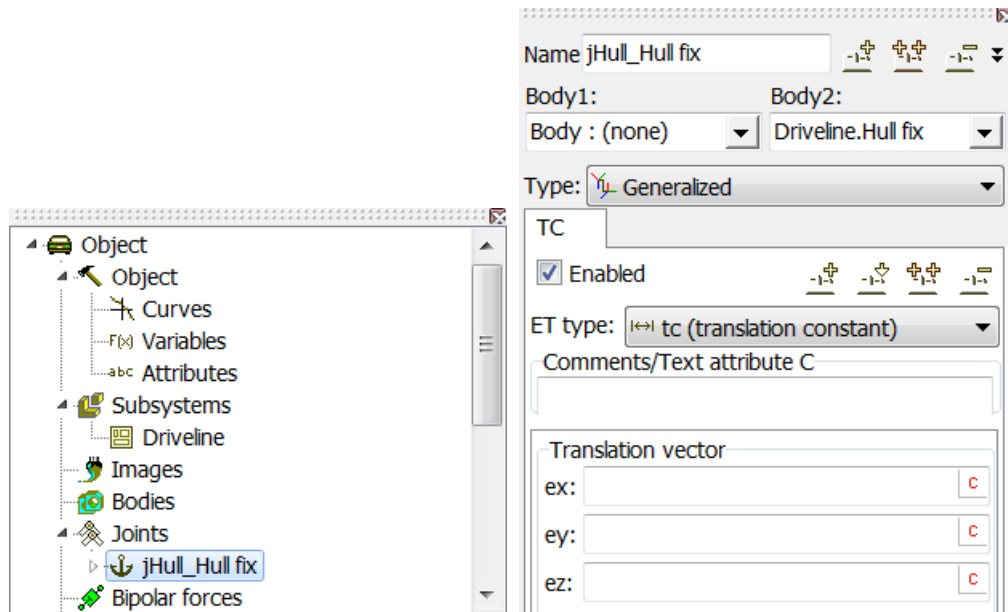

Figure 1.111. Joint for the connection of the fictitious driveline body with the TV hull

Apart from the subsystem, the object contains a joint (Figure 1.111). The first joint body is not assigned, and the second one is the fictitious driveline body *Hull fix*, 1.1.6.2.1 "Fictitious body", p. 1-88. The joint connects rigidly the fictitious body with the TV hull after adding the transmission to the TV model.

Now consider elements of the subsystem.

1.1.6.2.1. Fictitious body

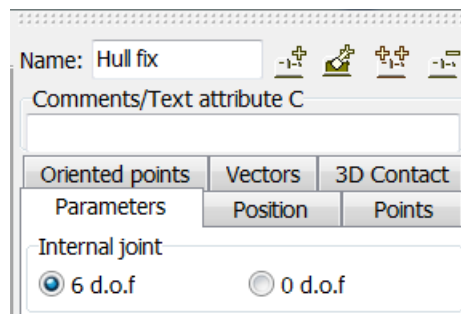



Figure 1.112. Fictitious body

The fictitious body in the transmission model replaces the TV hull. This means that all joints and force elements connected to the hull are connected to the fictitious body instead. When the transmission is added to the TV, the fictitious body is fixed to the TV hull by a special joint, Figure 1.111.

The fictitious body has zero inertia parameters as well as an internal joint with six degrees of freedom (Figure 1.112), which is ignored after fixing of the body with the TV hull. Please note that a body with an internal joint is created by the button .

1.1.6.2.2. Internal combustion engine

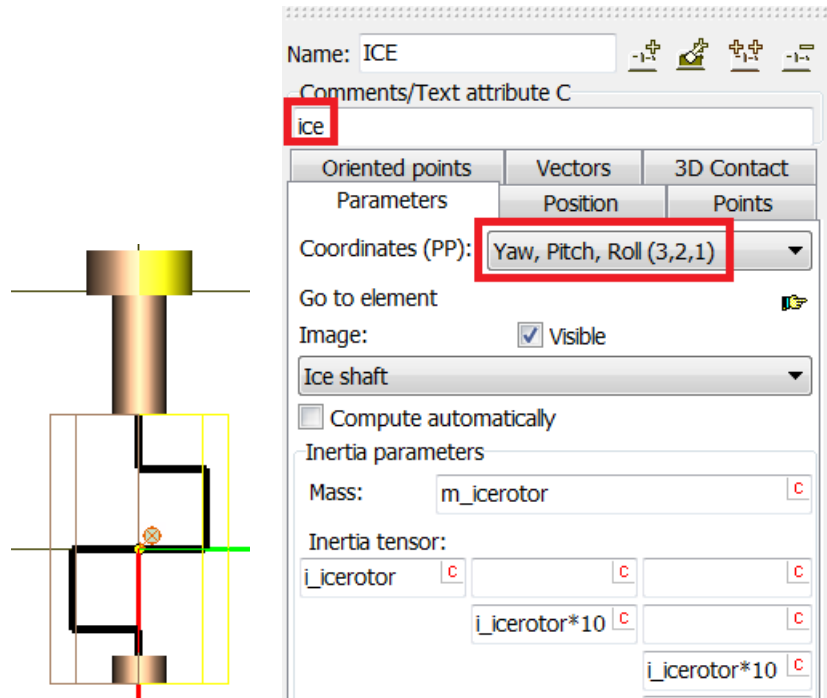

Figure 1.113. ICE shaft

ICE parameters are defined in simulation program and detailed described in [Chapter 22](#) of the user's manual. In the simplified transmission models the engine is described by one body and one joint.

The body accepts the inertia properties of the engine shaft, connecting rod and other joint parts. It is important to specify accurately the moment of inertia relative to the rotation axis, which is parameterized by the identifier *i_icerotor*.

The body must be marked by the text attribute *ice*, Figure 1.113, according to which the program recognize the ICE in the model.

Please note that the sequence of rotations yaw, pitch, roll (3,2,1) is assigned to the body through the **Coordinates (PP)** drop down menu. PP is the abbreviation for the Park Parallel solver. The engine shaft rotates often rapidly, and this type of coordinates improves the simulation step size.

The revolute joint specifies the rotational degree of freedom for the engine shaft and simultaneously sets the engine torque by the standard identifier *ice_torque*, Figure 1.114.

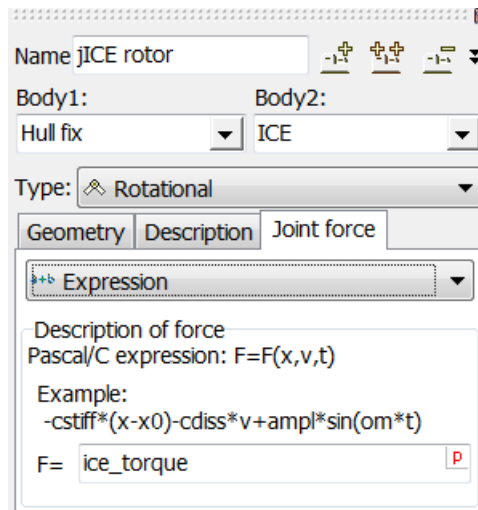

Figure 1.114. Joint specifying rotation of the engine shaft and engine torque

1.1.6.2.3. Main clutch, torque converter

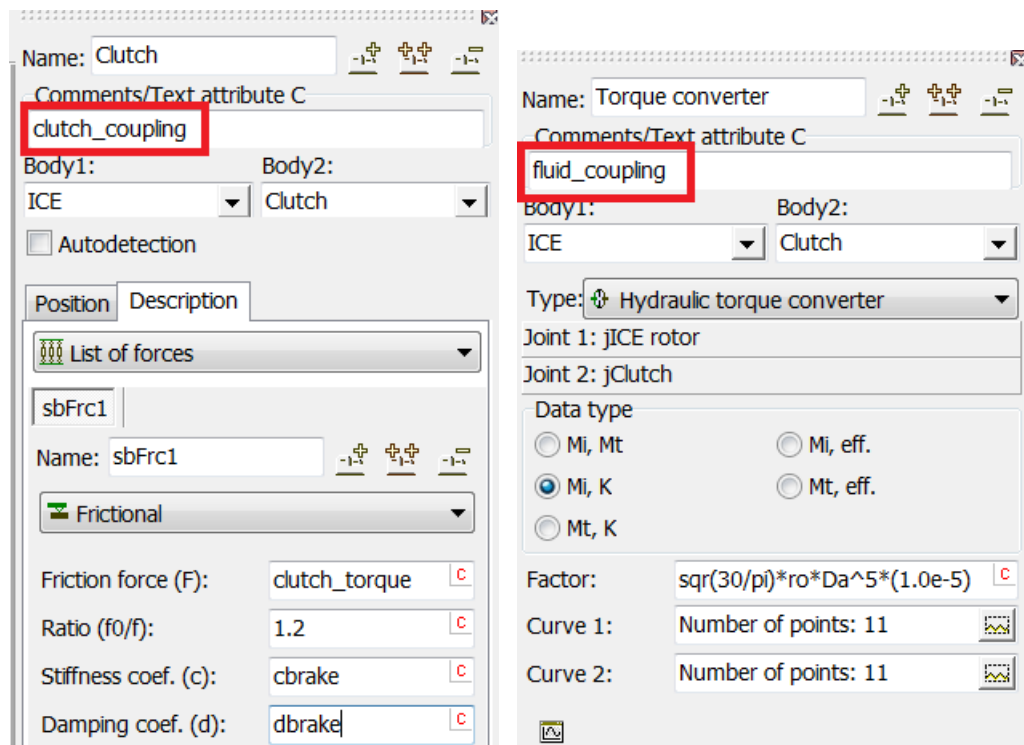

Figure 1.115. Models of clutch and torque converter

Either the main clutch or the torque converter is used for the engine-gearbox coupling, Figure 1.115.

The main clutch is modeled by a scalar torque of the frictional type. The force element must be marked by the text attribute *clutch_coupling* for automatic identification of the element. The frictional torque is parameterized by an identifier with the default value *clutch_torque*. The identifier is used for setting the computed value of the torque in dependence of the pedal position.

The torque converter is also presented in the transmission model as a special force element. The element is marked by the text attribute *fluid_coupling*, Figure 1.115.

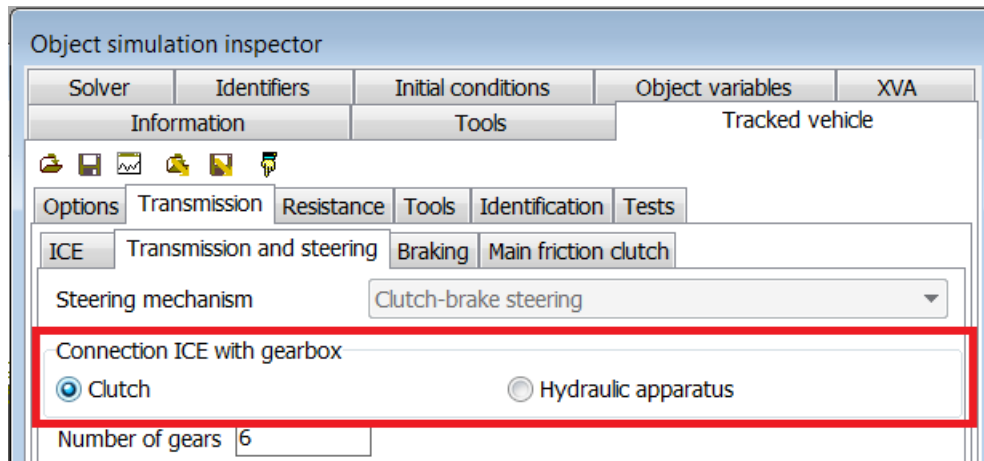

Figure 1.116. Selection of engine-gearbox coupling type

The user selects one of the two force elements as an active one before start of the simulation process, Figure 1.116.

1.1.6.2.4. Gearbox

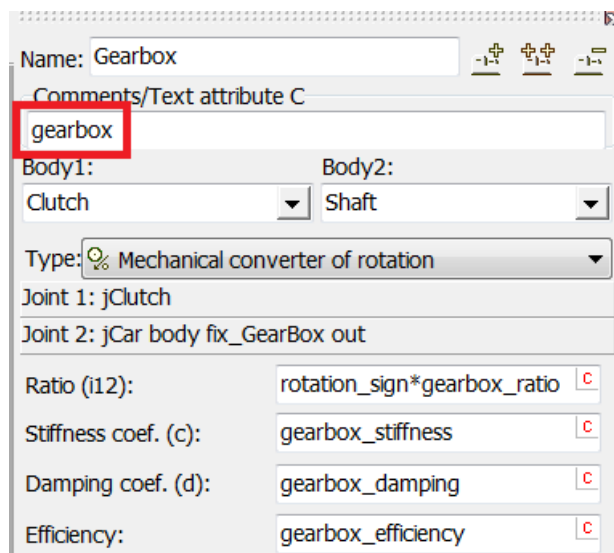

Figure 1.117. Gearbox as a force element

A simplified model of a gearbox is presented by the special force element of the 'Mechanical converter of rotation' type, Figure 1.117.

Successful identification of the element by the program requires the standard text attribute of this element *gearbox*.

The force parameters in Figure 1.117 are set by identifiers, which default values are:

- *gearbox_ratio* is the value of gear ratio,
- *gearbox_stiffness* (Nm/rad) is the stiffness constant if the gearbox, which can be different for various gear ratios,
- *gearbox_efficiency* is the gearbox efficiency for every ratio.

The *rotation_sign* identifier with the value 1 or -1 is used for specifying a correct rotation direction, Figure 1.117.

1.1.6.2.5. Stopping brake

The stopping brake is modeled by two joint torques of the 'Frictional' type, Figure 1.118. The torques brake input shafts of the final drives. The recommended (default) identifier for parameterization of the torque is *brake_torque*. In the case of the clutch-brake steering system, the stopping brakes are used for the vehicle steering. Application of the right brake leads to the right turn of the vehicle. The standard identifiers *turn_right* (equals 1 for the right turn) and *turn_left* (equals 1 for the left turn) activate the necessary brake according to the expressions (Figure 1.118)

$$brake_torque*(1-turn_right),$$

$$brake_torque*(1-turn_left).$$

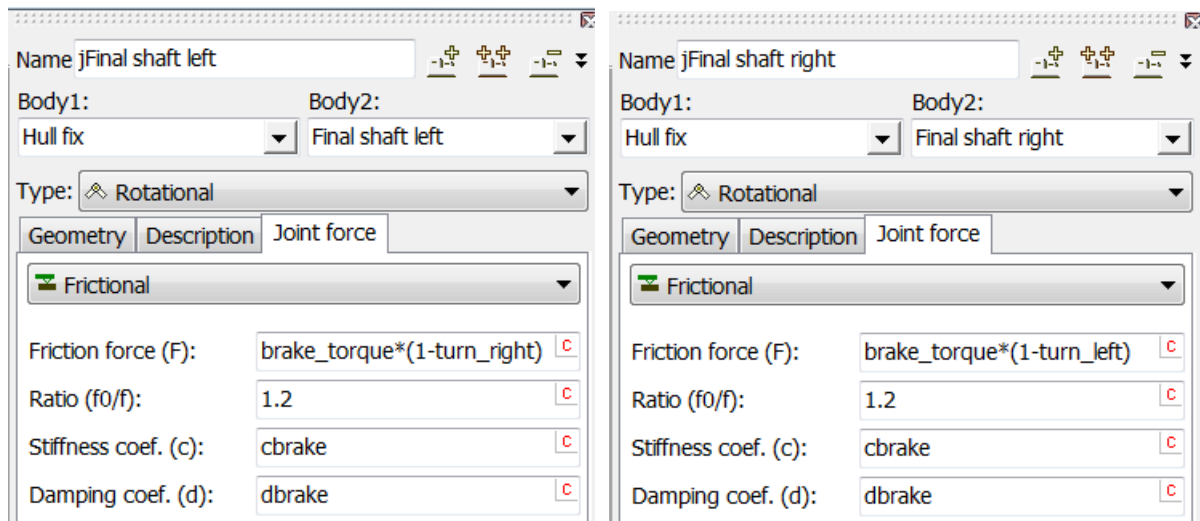

Figure 1.118. Brake torques

1.1.6.2.6. Final drive

The final drives are modeled by the special force elements of the 'Mechanical converter of rotation' type, Figure 1.119. Consider some features of the element descriptions:

- the second body is the *External* one; the drive wheels (sprockets) are assigned automatically by adding the transmission to the TV model;
- the elements are marked by the text attributes *Left sprocket* (left final drive) и *Right sprocket* (right final drive), which allows the program identifying the left and right elements;
- element parameters set by identifiers.

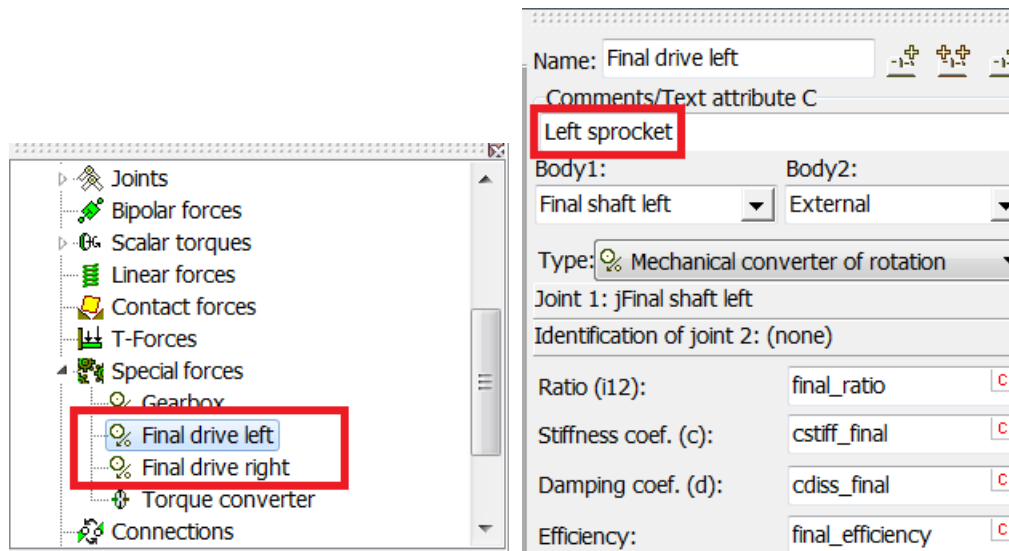

Figure 1.119. Left final drive

1.1.6.2.7. Identifiers

The model of transmission contains identifiers, which are used for the TV control. Three types of identifiers are used:

Control identifiers (Figure 1.120) used by the simulation program for the direct transmission control.

Name	Expression	Value	Comment
throttle_position	0		
gearbox_position	0		
clutch_position	0		
brake_position	0		
turn_factor	0		0 - straightforward, 1 - right, -1 - left

Figure 1.120. Transmission control identifiers

Identifiers parameterizing model elements are also used for control the transmission both by the program and by the user. Some of these identifiers are mentioned above. Consider here the list of main identifiers.

Gauge is used for specifying sizes and positions of elements such that one transmission model can be used for models of TV with different gauge value.

Gearbox_ratio is the gearbox ratio value. The identifier is changed by the program according to the current value of the control identifier *gearbox_position*.

Brake_torque is the identifier of the stopping brake torque. The numeric value of this identifier is assigned by the program according to the position of the brake pedal specifying be the control identifier *brake_position*.

Ice_torque is the engine torque. The torque is computed according to the ICE model in dependence on the throttle position specified by the control identifier *throttle_position*.

Clutch_torque is the value of the main clutch torque. The torque is computed according to the current value of the control identifier *clutch_position*.

Sprocket_front is equal to 1 for the front-drive TV and -1 for the rear-drive TV. The identifier is used for parameterization of the transmission geometry.

Turn_right (turn_left): value 1 corresponds to the left (right) turn of TV otherwise the value is 0.

Identifiers computing transmission ratios give the program general information about conversion of the engine speed to the TV speeds. For instance they are used for internal evaluation of the turn radii.

Main_ratio (km/h / rpm) is the ratio of TV speed to the engine speed for the gearbox ratio equals to 1. In the case of the clutch-brake steering system it is computed as

$$r_sprocket/final_ratio*3.6*pi/30.$$

where *r_sprocket* is the drive wheel radius.

Transmission_ratio (km/h / rpm) is the ratio of TV speed to the engine speed for the given value of the gearbox ratio, i.e.

$$transmission_ratio=main_ratio/gearbox_ratio.$$

Steer_ratio (km/h / rpm) is the ratio of the track speed decrease due to steering to the engine speed.

Steer_speed_ratio is the ratio of speeds of inner to outer tracks in turning. If we consider a "Maybach" steering system, it is computed as

$$steer_speed_ratio=(transmission_ratio-steer_ratio)/transmission_ratio.$$

1.1.6.2.8. Steps after adding transmission model

A type of the steering system according to Table 1.20 is assigned to the model. The type variable is used by the TV control algorithms by simulation.

The TV gauge value is set to the transmission subsystem. This step requires the identifier *gauge* both in the TV and the transmission models (Sect. 1.1.5.2. "Connection of track with hull", p. 1-82, Sect. 1.1.6.2.7. "Identifiers", p. 1-93).

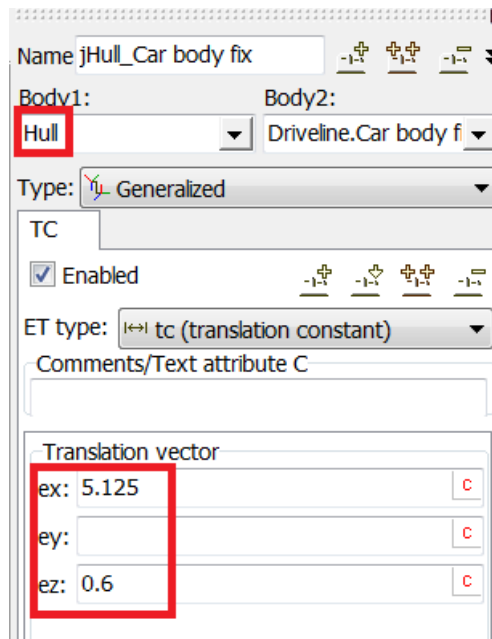

Figure 1.121. Joint connecting fictitious body of transmission with hull

3. The fictitious body of the transmission is connected rigidly with the TV hull (Sect. 1.1.6.2.1. "Fictitious body", p. 1-88). The hull is assigned to the first body in the corresponding joint (it is necessary to mark the hull body by the standard name or the text attribute *Hull*, Sect. 1.1.5.1. "Adding a hull", p. 1-80). In addition the joint specifies a shift according to the sprocket position relative to the hull, Figure 1.121.

4. The identifier *sprocket_front* value +1 or -1 is assigned according to the position of the drive wheel, Sect. 1.1.6.2.7. "Identifiers", p. 1-93.

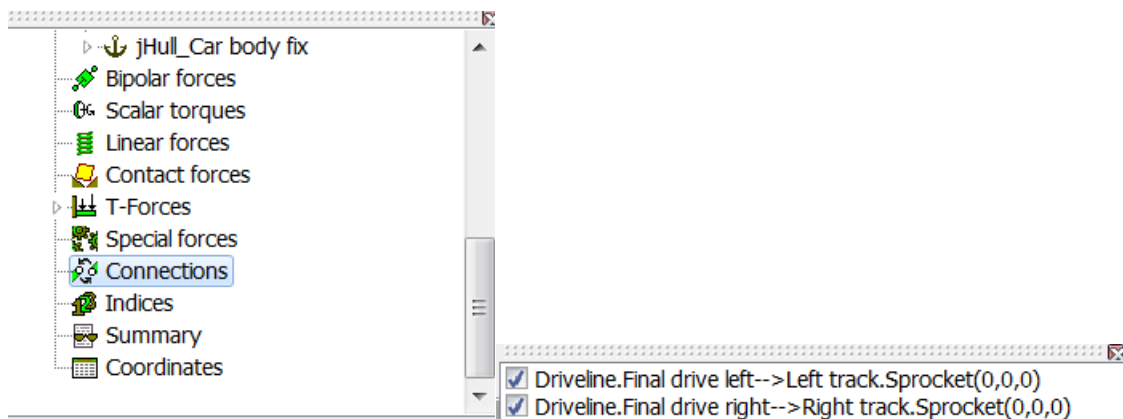

Figure 1.122. Assignment of second bodies to external elements

1. External elements in the transmission subsystem are finalized by assignment of the second bodies, Figure 1.122. External elements are two final drives, and the second bodies are drive wheels. This step succeeds if the necessary text attributes are assigned to elements. Otherwise the step must be done manually.

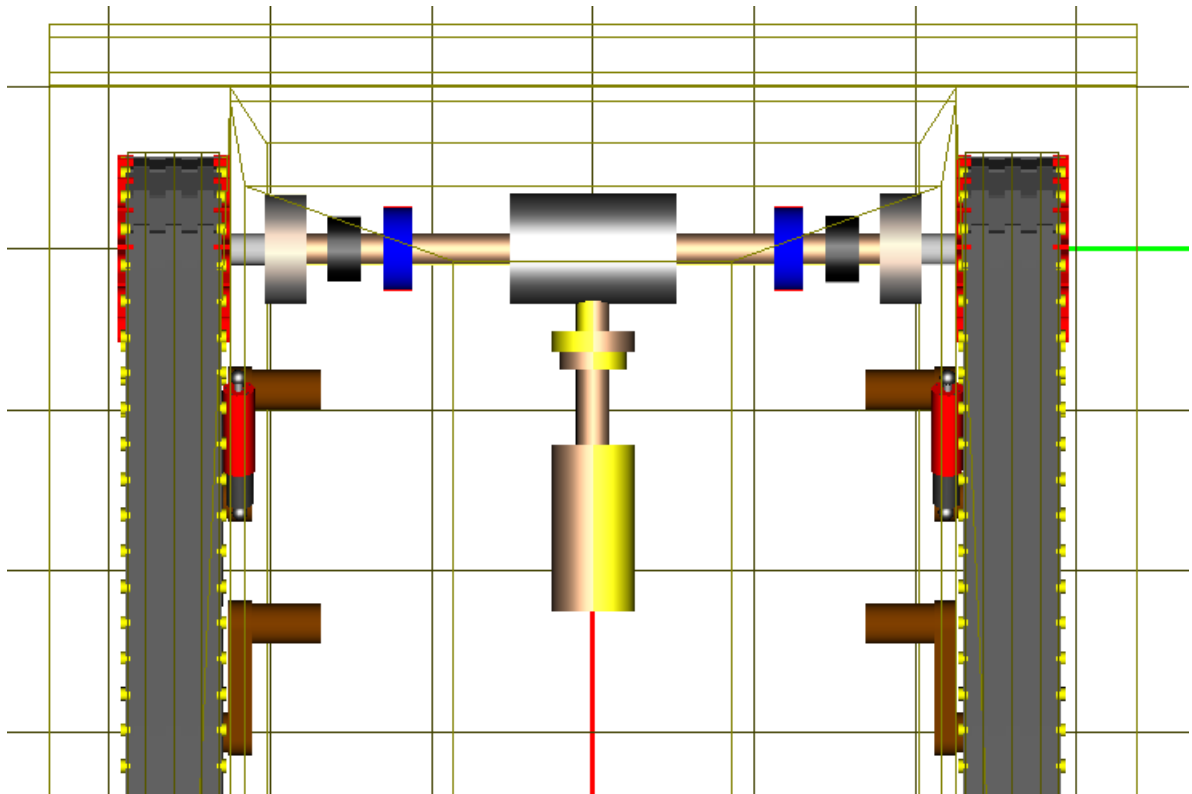

Figure 1.123. Model of tracked vehicle with transmission

If all steps succeed, the TV model with transmission is completed, Figure 1.123.

1.1.6.3. Clutch-Brake steering system

Description of the clutch-brake steering system can be found in [1], [2], [3]. For the vehicle turning, the steering clutch for the inside track is disengaged, and the brake is usually applied.

The most part of the transmission is described in Sect. 1.1.6.2. "*Common element of standard transmission models*", p. 1-87. Here we consider the models of steering clutches only.

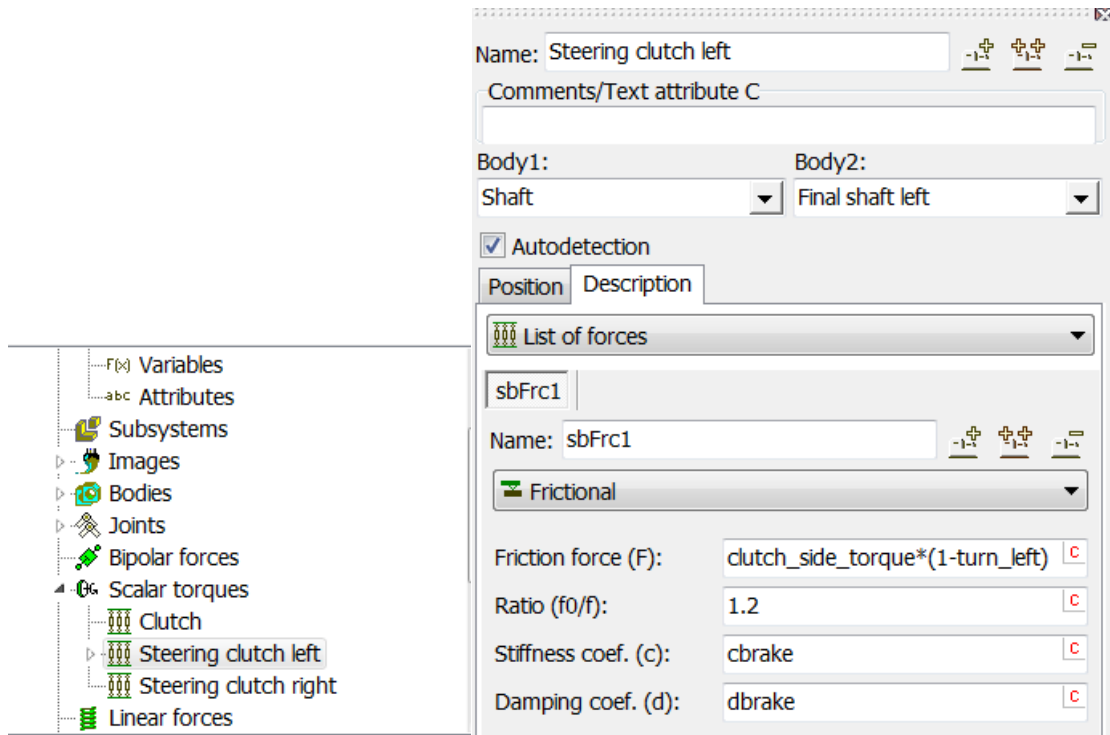

Figure 1.124. Steering clutches

The clutches are modeled by scalar torques of frictional type, Figure 1.124. The force elements connect the output shaft of the gearbox (body *Shaft*) with input shafts of the final drives (bodies *Final shaft left* and *Final shaft right*). The value of frictional torque is parameterized by the identifier *clutch_side_torque*. Engagement and disengagement of the clutches are made by the standard identifiers *turn_right* and *turn_left*, Sect. 1.1.6.2.7. "Identifiers", p. 1-93. Zero values of these identifiers lead to the straight-ahead motion. If *turn_right*=1, the right clutch is disengaged for the right turn, and *turn_left*=1 for the left turn.

1.1.6.4. Planetary gear steering system

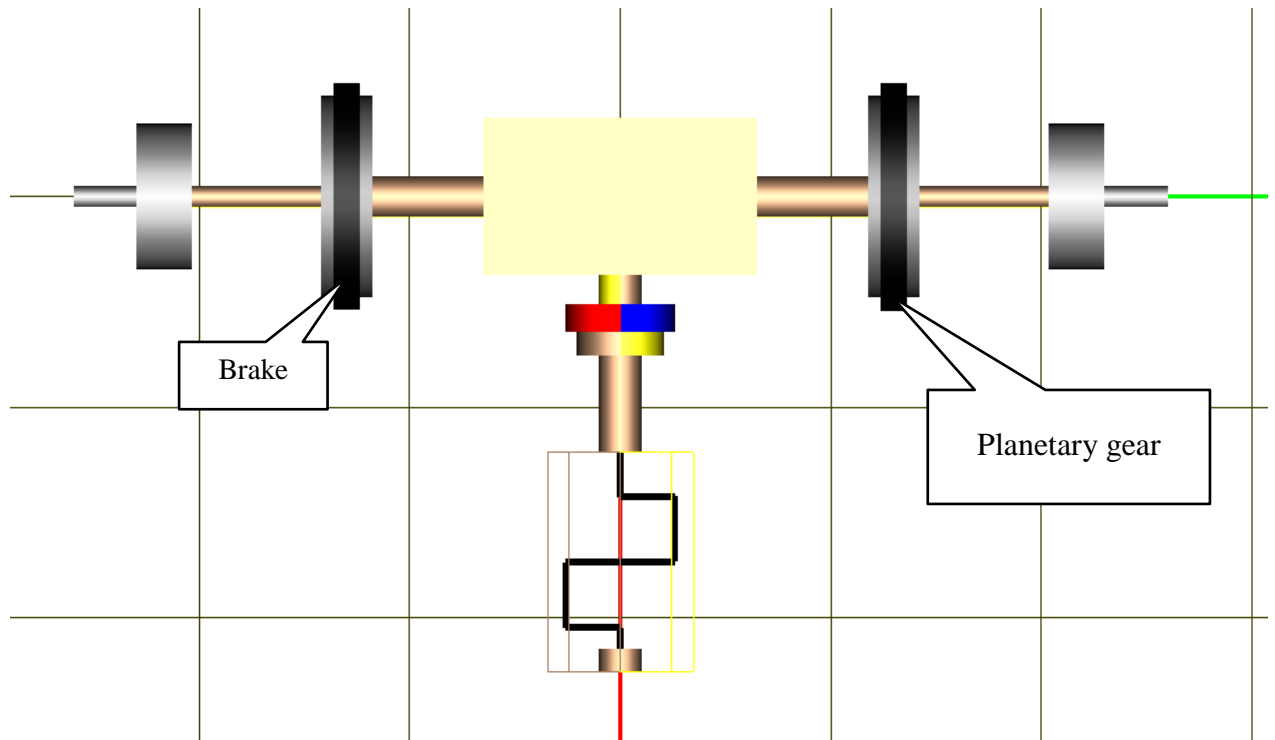

Figure 1.125. Transmission and planetary gear steering system

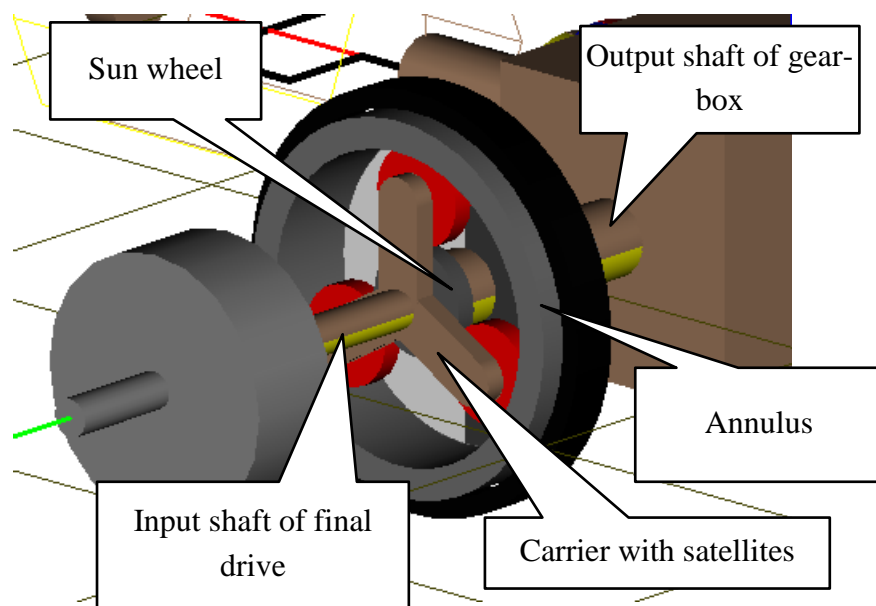

Figure 1.126. Planetary gear

See [1] for the mechanism description. Two planetary gear mechanisms are implemented in the model. The sun wheels are rigidly connected with the output shaft of the gearbox; all three parts are presented in the model by one body *Output shaft*, Figure 1.126. The input shaft of the final drive is rigidly connected with the carrier (bodies *Carrier left* and *Carrier right*).

Two clutches in engaged state connect the carriers and annuli of planetary mechanisms so that the planetary mechanism rotates as a rigid body. The clutches are presented in the model by

scalar torques *Steering clutch left* and *Steering clutch right*, Figure 1.124. Gear rings are bodies *Annulus left* and *Annulus right*. Brakes stop ring gears.

Description of brakes and clutches is similar to those in Sect. 1.1.6.2.5. "*Stopping brake*", p. 1-92 (brakes) and 1.1.6.3. "*Clutch-Brake steering system*", p. 1-96 (clutches).

In a straight line motion, the clutches are engaged and the brakes are released. For a turn, the clutch on the inner track is disengaged and the brake is applied, which lead to decrease of the carrier speed.

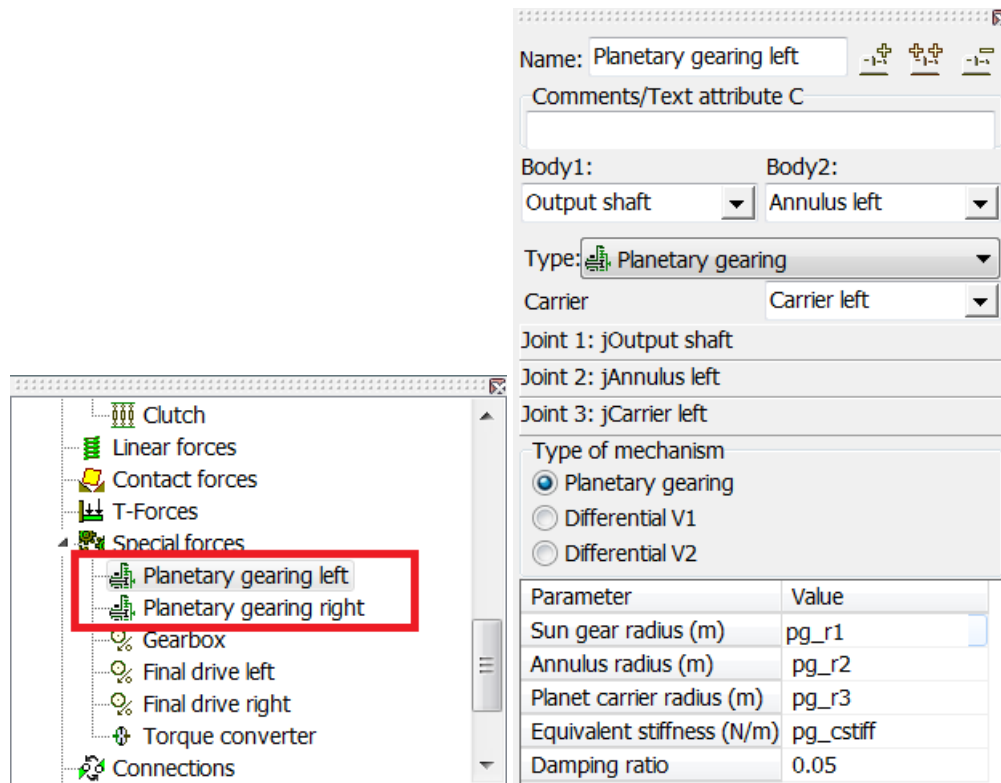

Figure 1.127. Model of planetary gearing

Consider a model of the planetary gears. For simplified modeling, a special force element of the **Planetary gearing** type is used, Figure 1.127.

Radii of gears are parameterized, which allows specifying the model geometry. Main ratios are computed in the list of identifiers:

annulus_ratio is the gear ratio for the braked sun wheel;

sun_ratio is the gear ratio for the braked annulus wheel.

It is important that the *sun_ratio* identifier is equal to the speed ratio of the inner track to the outer one in steering [1].

1.1.6.5. Controlled differential steering system

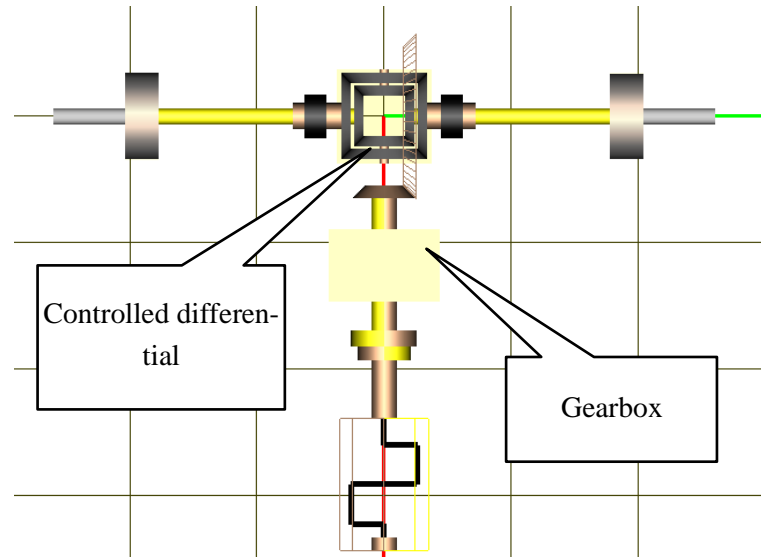

Figure 1.128. Transmission with controlled differential steering

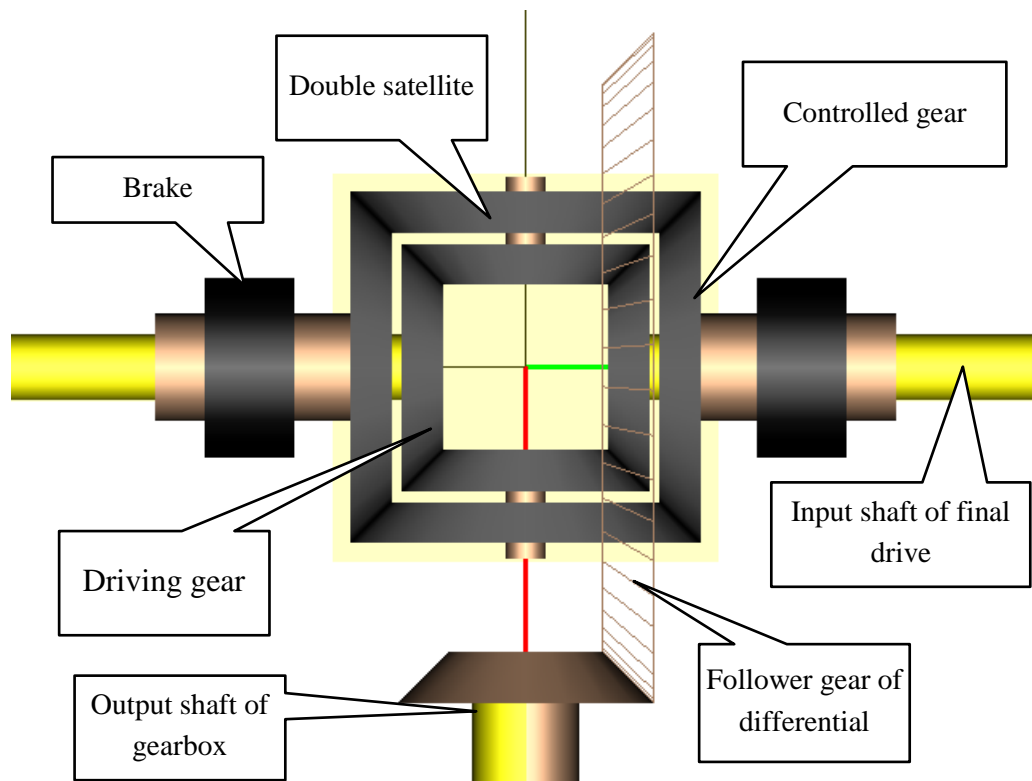

Figure 1.129. Controlled differential

See description of the mechanism in [1], [2], [3].

The most part of the mechanism is described in Sect. 1.1.6.2. "Common element of standard transmission models", p. 1-87. Here we consider the model of the controlled differential, which consists of seven bodies:

Differential housing;

Sun wheel left and *Sun wheel right* are the controlled gears with rigidly connected input shafts of the finales drives;

Planet wheel 1 and *Planet wheel 2* are two double satellites;

Controlled wheel 1 and *Controlled wheel 2* are two controlled gears.

All these bodies have rotational degrees of freedom relative to the hull except of the satellites, which rotation axis are connected with the differential housing.

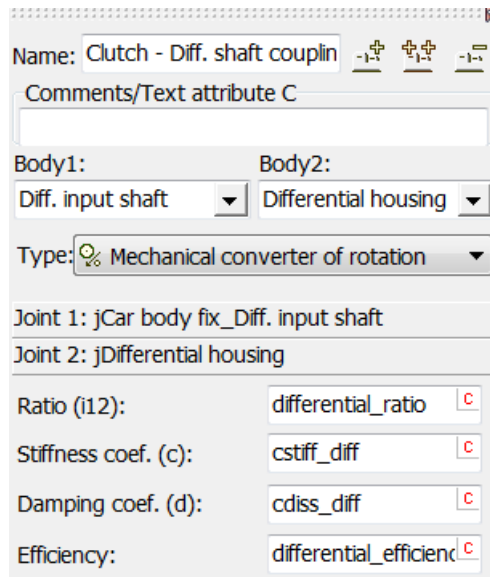

Figure 1.130. Transmission – crown wheel gearing

The special force element of the ‘Mechanical converter of rotation’ type is used for transfer of rotation from the output shaft of the gearbox to the crown wheel. The gearing ratio is parameterized by the *differential_ratio* identifier.

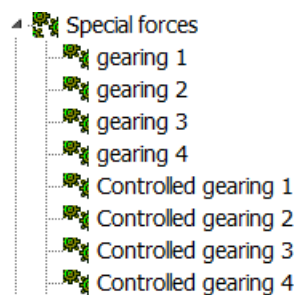

Figure 1.131. Differential gearings

Eight bevel gearings with ratio 1 are modeled the differential mechanism:

Gearing 1: gears *Sun wheel left* and *Planet wheel 1*;

Gearing 2: gears *Sun wheel left* and *Planet wheel 2*;

Gearing 3: gears *Sun wheel right* and *Planet wheel 1*;

Gearing 4: gears *Sun wheel right* and *Planet wheel 2*;

Controlled gearing 1: gears *Planet wheel 1* and *Controlled wheel 2*;

Controlled gearing 2: gears *Planet wheel 2* and *Controlled wheel 2*;

Controlled gearing 3: gears *Planet wheel 1* and *Controlled wheel 1*;

Controlled gearing 4: gears Planet wheel 2 and Controlled wheel 2.

For steering, the brakes decelerate the rotation of the corresponding controlled gears up to the full stop. In the straight line motion, the brakes are released and the controlled differential works as a usual differential. In turn, the brake for the inner track is applied and decelerates the controlled gear. As a result, the rotation of the driving gear on the brake side is decelerated, and the opposite driven gear is accelerated; the TV keeps speed by turning. Simultaneous applying the brakes works as a stopping brake. The brakes are described by joint torques in joints for the controlled gears, Figure 1.132.

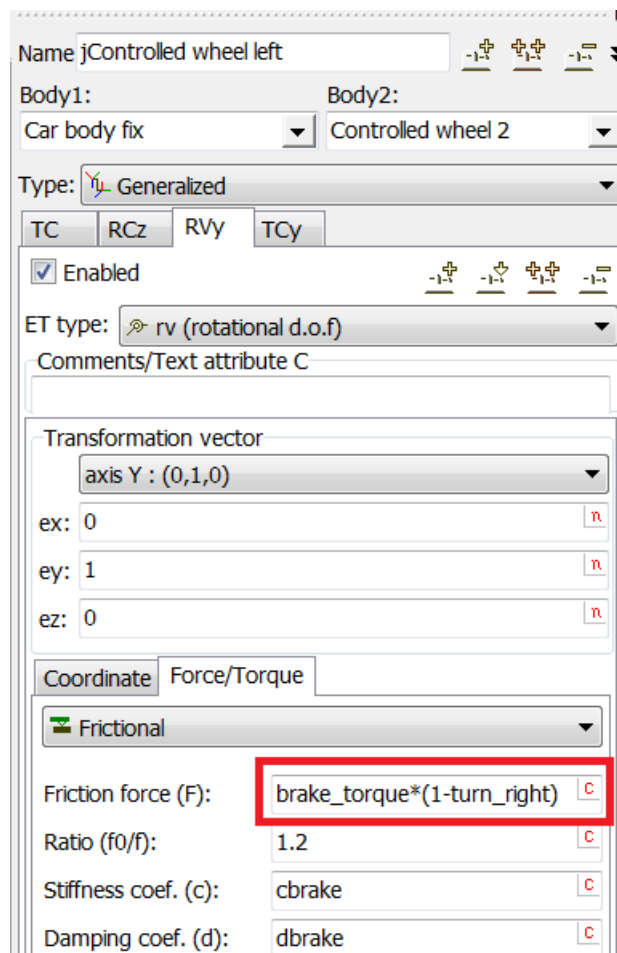

Figure 1.132. Brake torque

1.1.6.6. "Maybach" double differential steering system

This steering system was initially implemented during WWII in the German tank PzKw V Panther [2], [3].

The central elements of the steering system are two planetary gears, which summarize two flows of energy. The annuli of gears are rigidly connected with the output gearbox shaft, the *Main shaft* body. The carriers are connected with the input shafts of the final drives, bodies *Carrier left* and *Carrier right*. In a straight line motion, the sun wheels (bodies *Sun wheel left*, *Sun wheel right*) are fixed by the steering brakes, and the steering clutches (the special forces *Steering clutch left*, *Steering clutch right*) are disengaged.

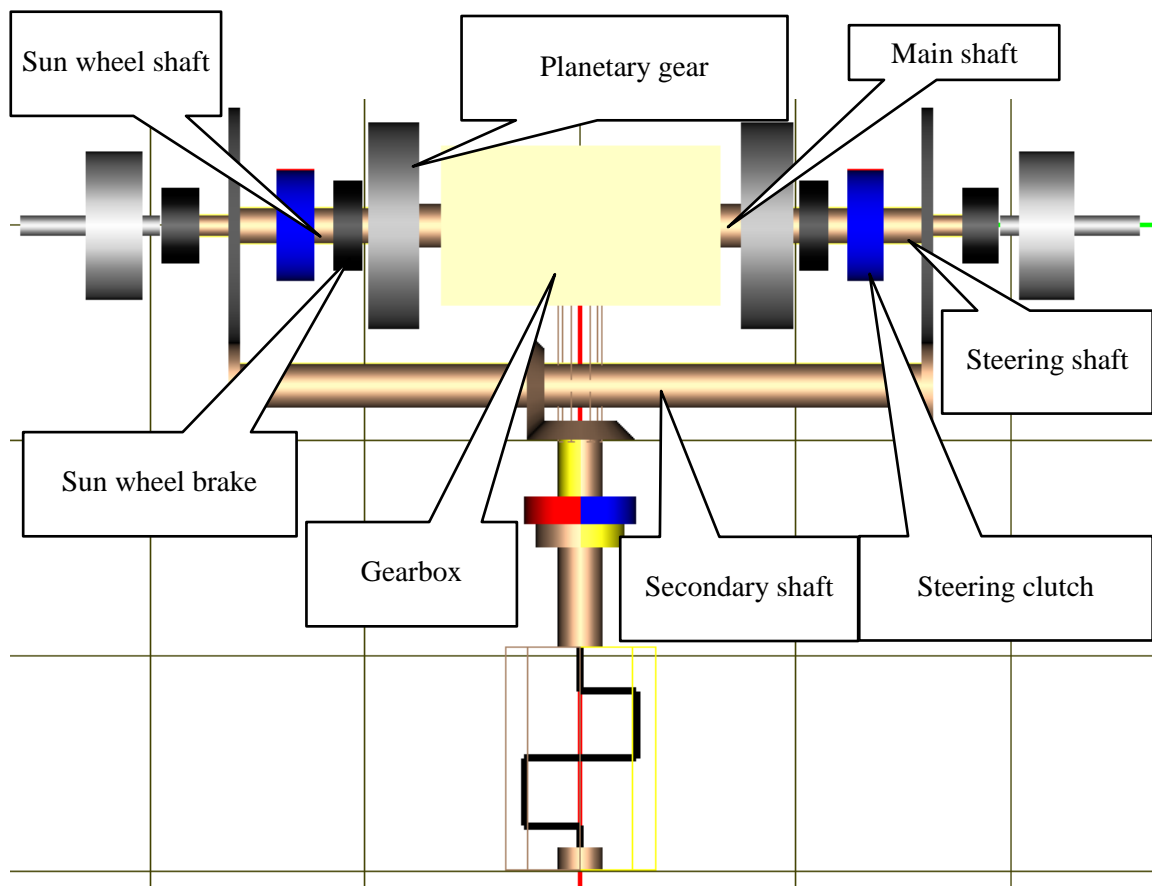

Figure 1.133. "Maybach" double differential steering system

In turning, the steering clutch for the inner track is engaged, the corresponding steering brake is released, and the sun wheel is rotated by the following chain: body *Secondary shaft* – simple gear (*Steer gear left/right*) – body *Steering shaft left/right* – sun wheel shaft. Rotation of the sun wheel makes the speed of the carrier and the inner track slower. Thus, steering reduces the TV speed.

Consider force elements except those described in Sect. 1.1.6.2. "*Common element of standard transmission models*", p. 1-87.

Secondary shaft coupling is the mechanical converter of rotation with the ratio equal to 1. The coupling drives the secondary shaft directly from the gearbox input shaft.

Planetary gearing left/right are the summarizing planetary gearings; the element description is similar to the planetary gears in Sect. 1.1.6.4. "*Planetary gear steering system*", p. 1-98.

Steer gear left/right are the simple gears driving the sun wheels in turnings. The gear ratio is parameterized by the identifier *steering_ratio*.

Steering clutch left/right are the scalar torques modeling the steering clutches. The clutch torques are described by the expressions

$$\begin{aligned} & steering_clutch_torque * turn_left, \\ & steering_clutch_torque * turn_right, \end{aligned}$$

where the identifier *steering_clutch_torque* parameterizes the torque of the engaged clutch.

Sun wheel brakes are described as joint torques in revolute joints *jSun left/right* by the expressions

$$\begin{aligned} & steering_brake_torque*(1-turn_left), \\ & steering_brake_torque*(1-turn_right), \end{aligned}$$

where the identifier *brake_sunwheel_torque* corresponds to the value of the applied brake.

Expressions for the torques produced by the clutches and brakes shows that in a straight line motion (*turn_left=turn_right=0*) the clutches are disengaged and the brakes are applied. For the left/right turn (*turn_left=1/0, turn_right=0/1*), the left/right clutch is engaged and the left/right brake is released.

Note, that the main is the output shaft of the gearbox.

Consider two useful expressions. The first one is the relation between engine and track speeds for the locked sun wheel

$$v = \frac{i_a r_s}{i_{fin} i_{gb}} \omega = k_{main} \omega.$$

Here $i_a = r_2/(2r_3)$ (the identifier *annulus_ratio*) is the planetary gear ratio for the stopped sun wheel, r_s is the sprocket radius (the identifier *r_sprocket*), i_{fin} is the final drive ratio (the identifier *final_ratio*), i_{gb} is the gearbox ratio (the identifier *gearbox_ratio*). The identifier *transmission_ratio* corresponds to the parameter k_{main} , track speed is measured in km/h, and engine speed is measured in rpm:

$$transmission_ratio = r_sprocket/gearbox_ratio/final_ratio*annulus_ratio*3.6*pi/30.$$

The second expression is the relation between the track and engine speeds in a turn by stopped annulus

$$v = \frac{i_s r_s i_{steer}}{i_{fin}} \omega = k_{steer} \omega.$$

Here $i_s = r_1/(2r_3)$ (the identifier *sun_ratio*) is the planetary gear ratio for the stopped annulus, i_{steer} is the ratio of the simple gear connecting the secondary shaft and the sun wheel (the identifier *steering_ratio*). The identifier *steer_ratio* corresponds to the parameter k_{steer} , track speed is measured in km/h, and engine speed is measured in rpm:

$$steer_ratio = r_sprocket*steering_ratio/final_ratio*sun_ratio*3.6*pi/30.$$

Using these parameters, the ratio of speeds of inner (v_i) and outer tracks (v_o) in steering looks like

$$v_i = \frac{(k_{main} - k_{steer})}{k_{main}} v_o.$$

In the model, this ratio is presented by the identifier *steer_speed_ratio*.

1.1.6.7. Double differential steering system

A disadvantage of the "Maybach" steering system is the decrease of the TV speed in turning. A mechanism considered in this section allows turning without slowing the motion, Figure 1.134.

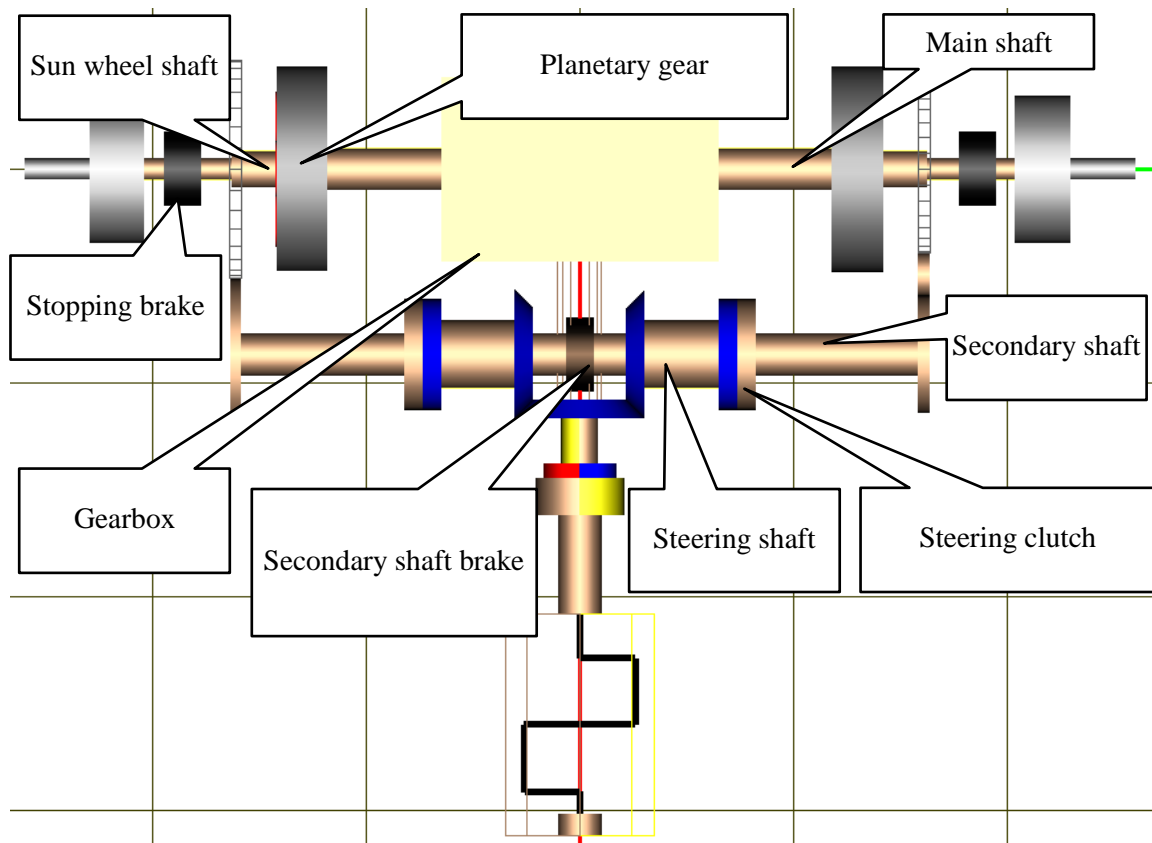

Figure 1.134. Double differential steering system

The body *Secondary shaft* is connected by gears the sun wheel shafts of two planetary mechanisms. The gears are modeled by special force elements *Steer gear left* and *Steer gear right*. The gear ratio is parameterized by the identifier *steering_ratio*. In a straight line motion of the TV, the secondary shaft is locked by a brake (a frictional torque in the joint *jSecondary shaft*), and the steering clutches *Steering clutch left/right* are disengaged.

For turning, the brake for the secondary shaft is released, and one of the steering clutches (the right one for the left turn) is engaged driving the secondary shaft in the necessary direction. So, the sun wheels of planetary gears are rotate in different directions increasing speed of the outer track and decreasing speed of the inner track.

The speed ratio of sprockets in turning for the inner (v_i) and outer (v_o) tracks looks like this:

$$v_i = \frac{k_{\text{main}} - k_{\text{steer}}}{k_{\text{main}} + k_{\text{steer}}} v_o.$$

1.1.6.8. Double differential steering system (SU)

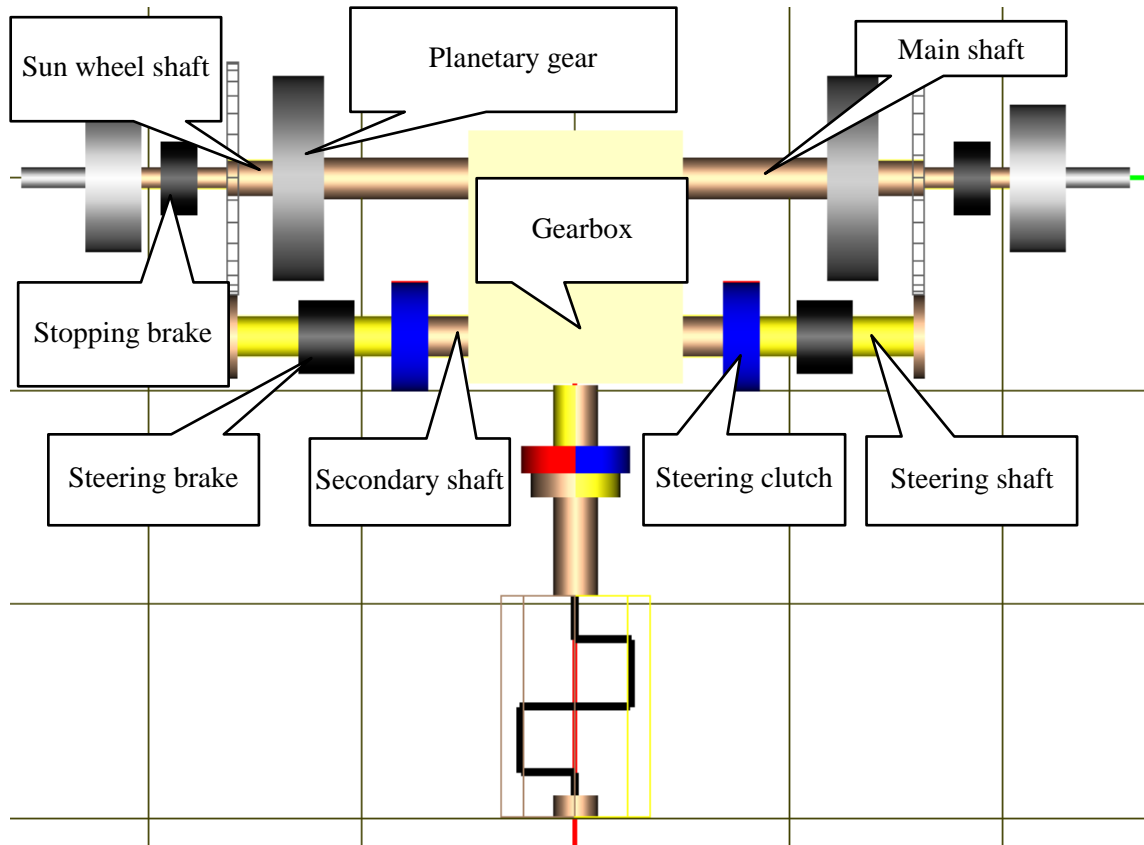

Figure 1.135. Modified double differential steering system

A modification of the "Maybach" double differential steering was implemented in the high-speed crawlers in USSR [4]. The mechanism in Figure 1.135 contains the same basic element as the "Maybach" system but some differences are important.

In a straight line motion, the steering clutches are engaged and the steering brakes are released, i.e. the sprocket rotation is summarized by planetary gears from two flows. In the gearbox the rotation of the secondary shaft drive the main shafts. Thus, the secondary shaft divides the energy on two, which are summarized by the planetary gears on the carries.

The mechanism allows the straight line motion on one power flow when the steering clutches are disengaged and steering brakes are applied.

For steering, the clutch on the side of the inner track is disengaged and the corresponding brake is released, i.e. the sun wheel is stopped and speed of the inner track decreases. The speed of TV in turning decreases like in the case of the "Maybach" steering system.

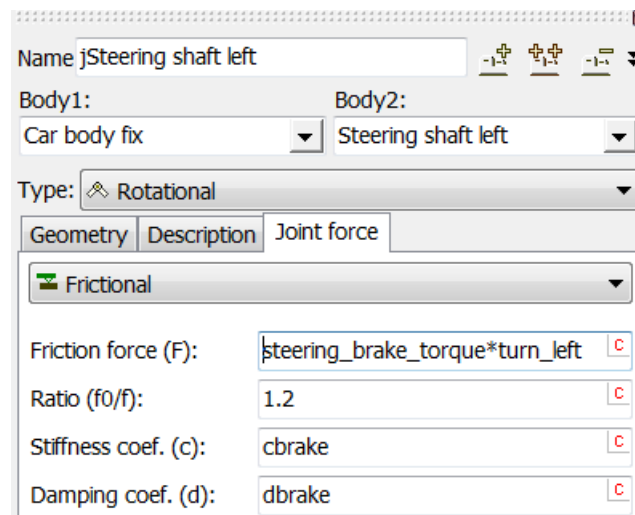

Figure 1.136. Steering brake torque

Steering brakes are described in joints *jSteering shaft left/right*, Figure 1.136. The speed ratio of sprockets in turning for the inner (v_i) and outer (v_o) tracks is

$$v_i = \frac{k_{\text{main}}}{k_{\text{main}} + k_{\text{steer}}} v_a.$$

1.1.6.9. Triple differential steering system

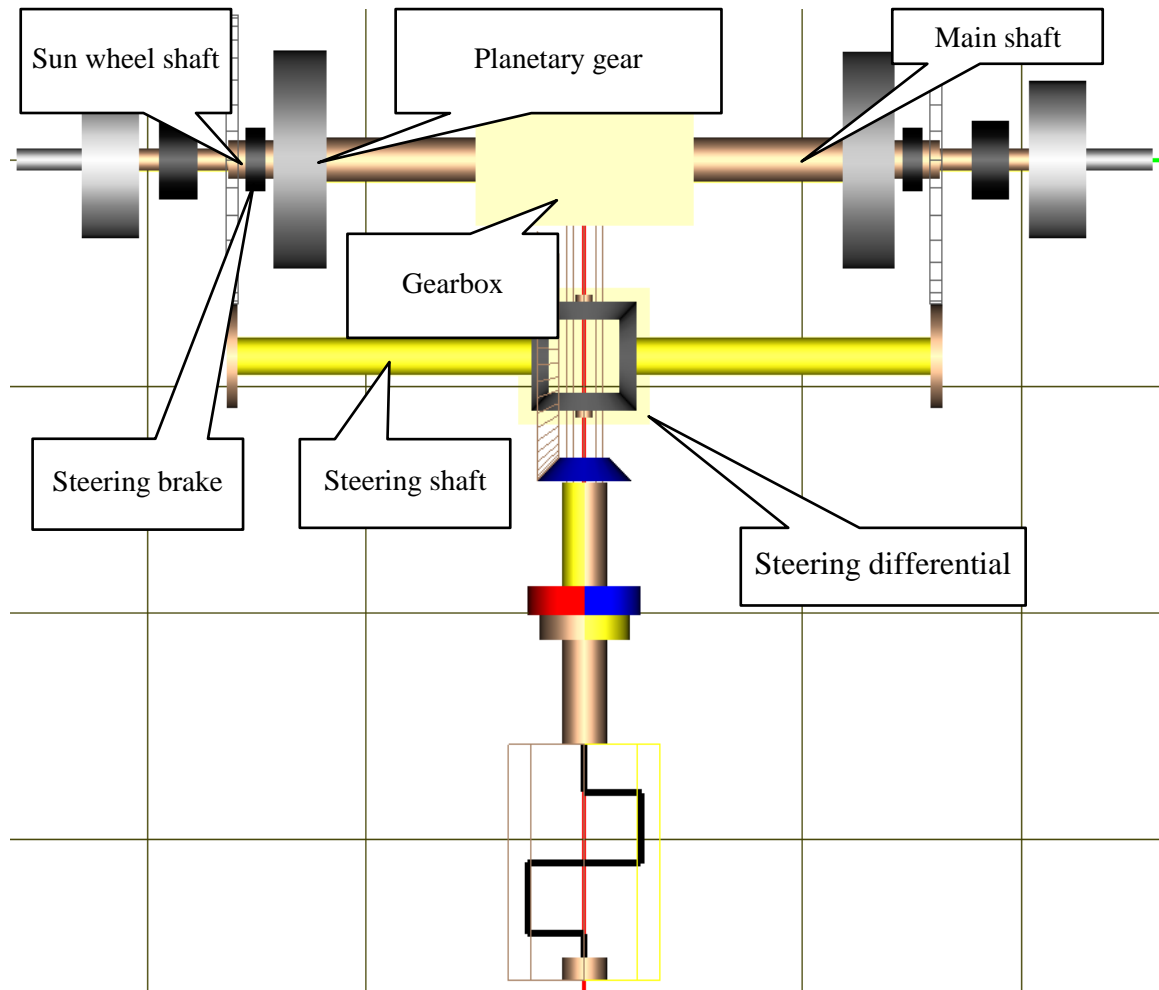

Figure 1.137. Triple differential steering system

This modification of the double differential steering system (Sect. 1.1.6.7. *"Double differential steering system"*, p. 1-104) allows replacing two steering clutches by two steering brakes, Figure 1.137.

In a straight line motion of TV, the steering brakes are released. For turning, the steering brake on the inner track side is applied to stop the sun wheel. Simultaneously, the steering differential increases the rotation speed of the sun wheel for the outer track.

1.1.6.10. Double differential steering system with hydrostatic drive (HSD)

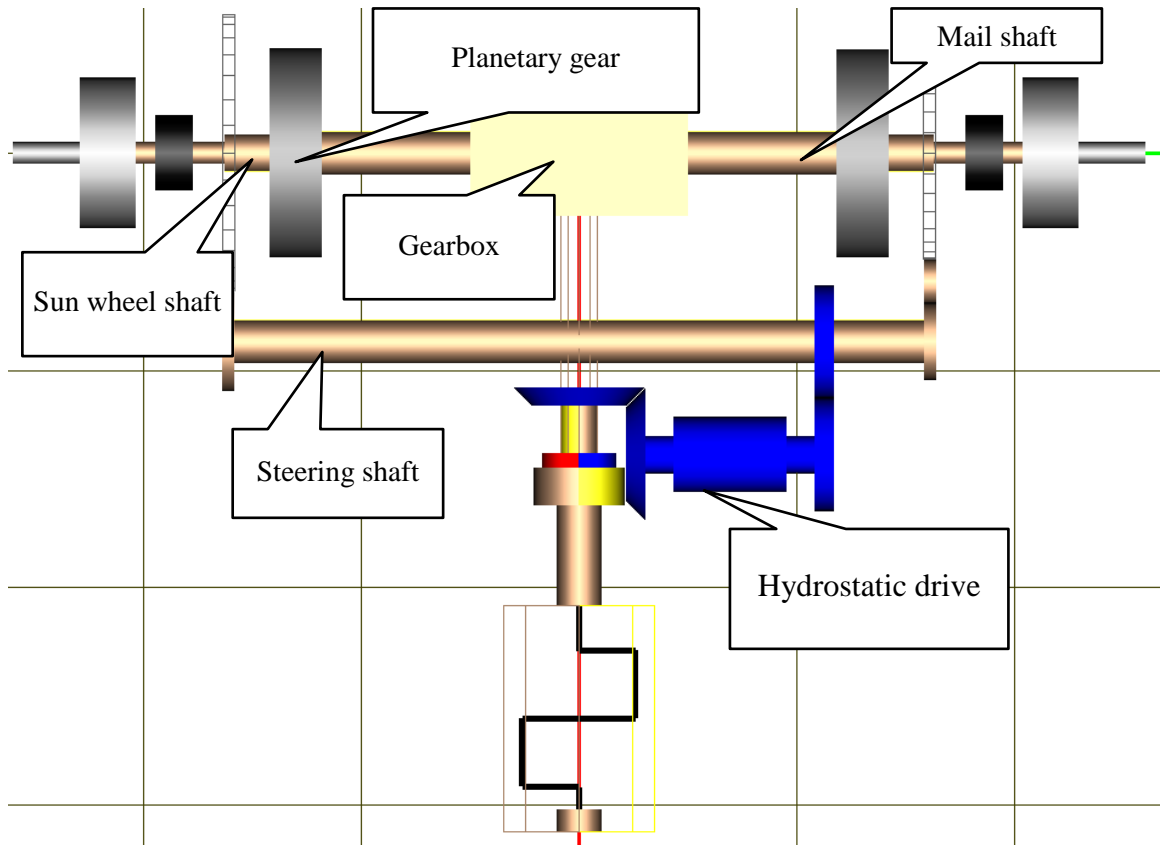

Figure 1.138. Double differential steering system with HSD

Name: HSD

Comments/Text attribute C

Body1: Clutch Body2: Input shaft

Type: Hydrostatic drive

Joint 1: jClutch
Joint 2: jInput shaft

Parameter	Value
Chamber volume (cm ³)	200
Max pump displacement (cm ³)	16
Max drive displacement (cm ³)	16
Pump control parameter	steering_angle
Drive control parameter	1
Relief pressure (MPa)	50
Charge pressure (MPa)	0.6
Pump damping (Nm s/rad)	d_pupm
Drive damping (Nm s/rad)	d_motor
Bulk modulus (N/m ²)	1.5e9
Leakage coefficient (m ⁵ /N/s)	leakage
Pressure scale factor	1e-6

Figure 1.139. Hydrostatic drive force element (HSD)

A hydrostatic drive allows turning TV with a continuously changing radius. The control parameter of steering is the normalized value of the pump valve specified by the identifier *steering_angle*, Figure 1.139. The control parameter is changed in the interval $[-1,1]$.

1.2. Simulation of TV dynamics

In this section we do not consider general methods of simulation of multibody systems. We discuss some features of simulation of TV with UM. It is recommended to have a look at [Chapter 4](#) of the manual “UM Simulation program” for studying the general methods of simulation.

1.2.1. Models of force interactions

Consider some features of force interaction of bodies in a model of TV.

1.2.1.1. Sprocket-pin interaction

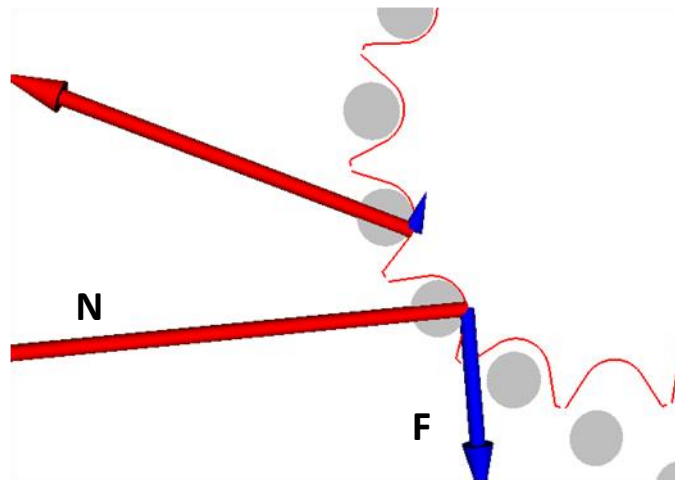

Figure 1.140. Pin-sprocket forces

Contact interactions of track pins with sprocket teeth transfers traction and brake torque to the track. A compliant contact model is used. Contact forces depend on penetration of pin and tooth profiles and produce two components, Figure 1.140: the normal force \mathbf{N} and the friction force \mathbf{F} . The normal component is the linear function of the penetration and its derivative. Detailed description of mathematical model of the contact force can be found in [Chapter 2](#) of the manual, Sect. *Force elements/ Contact forces / Points-Plane and Points-Z-surface types*.

Contact stiffness and damping constants as well as coefficient of friction are specified by the user, Sect. 1.2.4.4.1. *"Track contact parameters"*, p. 1-142.

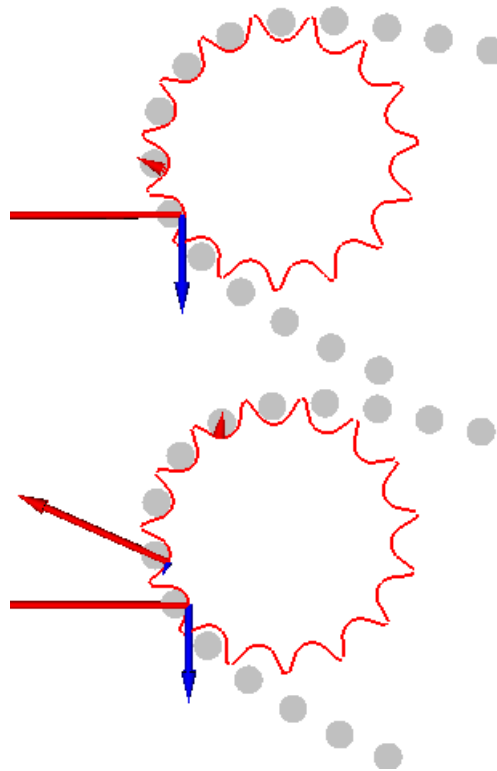

Figure 1.141. Animation window for pin-sprocket interactions

Pin-sprocket contact forces are visualized in a special animation window, Figure 1.141. Use the **Tools | Pin-sprocket contacts** menu command to open the window.

Restrictive forces appear by the lateral shift of a track link relative to the sprocket as well as by relative rotations. Models of these forces are described in Sect. 1.2.1.5. *"Restrictive force and moment"*, p. 1-119.

1.2.1.2. Track-ground interaction

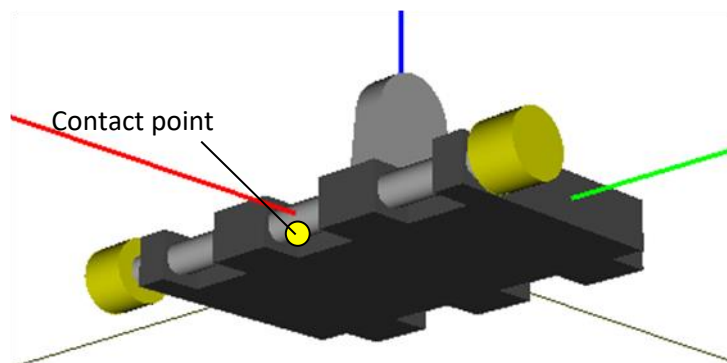

Figure 1.142. Contact point for a link

The standard contact element of the **Points-Z-surface** type is internally used for description of interaction between a track link and the ground. One contact point is automatically assigned to each of the links. The point is located in the middle of the front edge of a lower bounding rec-

tangle of the link, Figure 1.142. Z – surface is designed taking into account irregularities under each of the track.

Two models of ground are implemented: a linear model without sinkage and a model of soil with sinkage.

Remark. Set of contact points of a link specifying its geometry is planned to be allowed in the nearest future.

1.2.1.2.1. Ground model without sinkage

A linear viscous-elastic model is used for the normal force

$$N = -c_g \Delta - d_g \dot{\Delta},$$

where $\Delta, \dot{\Delta}$ is the depth of penetration of a contact point into the ground surface taking into account irregularities and its time derivative, c_g, d_g are stiffness and damping constants. The damping constant is computed according to the given value of the damping ratio β_g as

$$d_g = 2\beta_g \sqrt{c_g m_t},$$

where m_t is the mass of a track link.

Contact stiffness constants and damping ratio as well as coefficient of friction are specified by the user, Sect. 1.2.4.4.1. "Track contact parameters", p. 1-142.

This model can be used for modeling of ground without remarkable sinkage (concrete, asphalt and so on).

1.2.1.2.2. Bekker ground model

The Bekker model is implemented for ground taking into account sinkage processes [5], [1]

$$p = \left(\frac{k_c}{b} + k_\varphi \right) z^n. \quad (1.1)$$

Here p is the normal link-ground pressure; b is the minimal size on the contact patch b (length of a track link); n, k_c, k_φ are model parameters, z is the sinkage depth.

The Moor-Coulomb formula for the maximal shear strength is used in evaluation of friction forces

$$\tau_{\max} = c + p \tan \varphi,$$

where c is the cohesion, p is the normal stress, φ is the angle of internal friction.

For evaluation of the current value of the shear strength, the following relation is usually applied [1]

$$\tau(j, z) = (c + p \tan \varphi) (1 - e^{j/K}),$$

where j is the shear displacement of the link since the first contact with soil, and K is an empirical constant. The following simplified stress-displacement is implemented in UM

$$\tau(j, z) = \begin{cases} \frac{c + p \tan \varphi}{K} j, j < j^* \\ \tau_{\max}, j < j^* \end{cases}, j^* = \frac{K \tau_{\max}}{c + p \tan \varphi}. \tag{1.2}$$

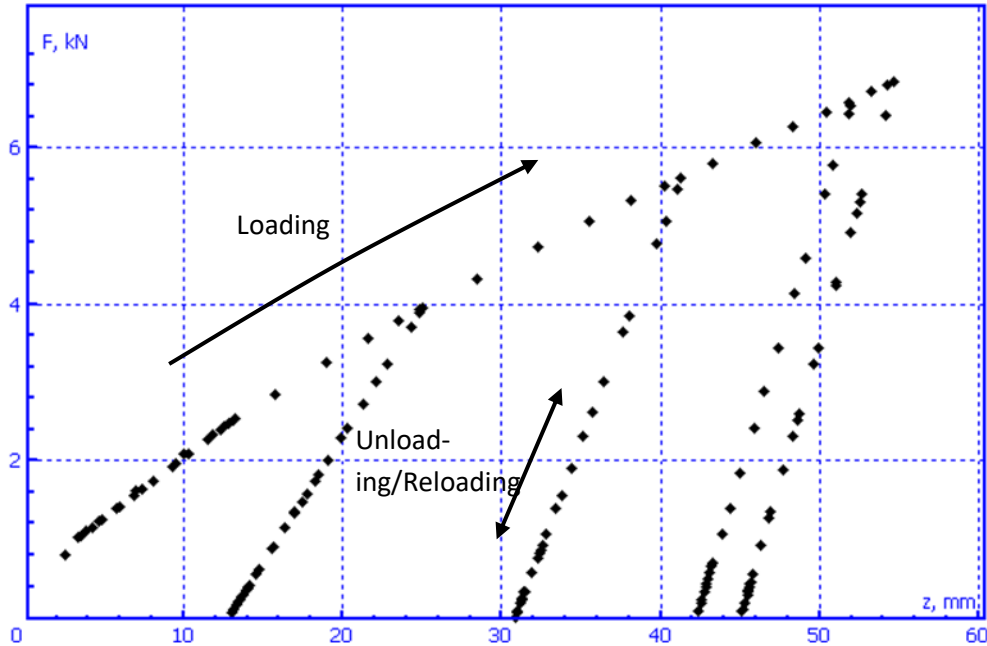

Figure 1.143. Example of track load force versus sinkage by loading and unloading/reloading processes

Eq. (1.1) is valid for the soil loading process. The linear model is implemented for the normal stress by unloading and reloading processes, figure 1.143

$$p = p_u - k_u(z - z_u) \tag{1.3}$$

Here p_u, z_u are the normal pressure and sinkage depth at the unloading start, k_u is the stiffness constant depending on z_u . Usually the stiffness constant increases with the growth of the sinkage z_u due to the compaction of soil. The linear model is recommended [1]

$$k_u = k_0 + A_u z_u, \tag{1.4}$$

which depends on two empirical constants k_0, A_u . This formula fails for small sinkage, and an increased value is applied.

The normal and the friction forces are computed by multiplication of the corresponding stress and strength on the track area S ,

$$N = pS, \quad F_{fr} = \tau S.$$

Thus, the soil model of (1.1) – (1.4) is specified by eight parameters

$$n, k_c, k_\varphi, c, \varphi, K, k_0, A_u$$

which depend on the type and composition of the ground, moisture, temperature and so on. These parameters are assessed from field tests. Books [5], [1] contain over 50 examples of soil parameters, which can be used by simulations. Several pressure-sinkage plots from the UM database are presented in Figure 1.144.

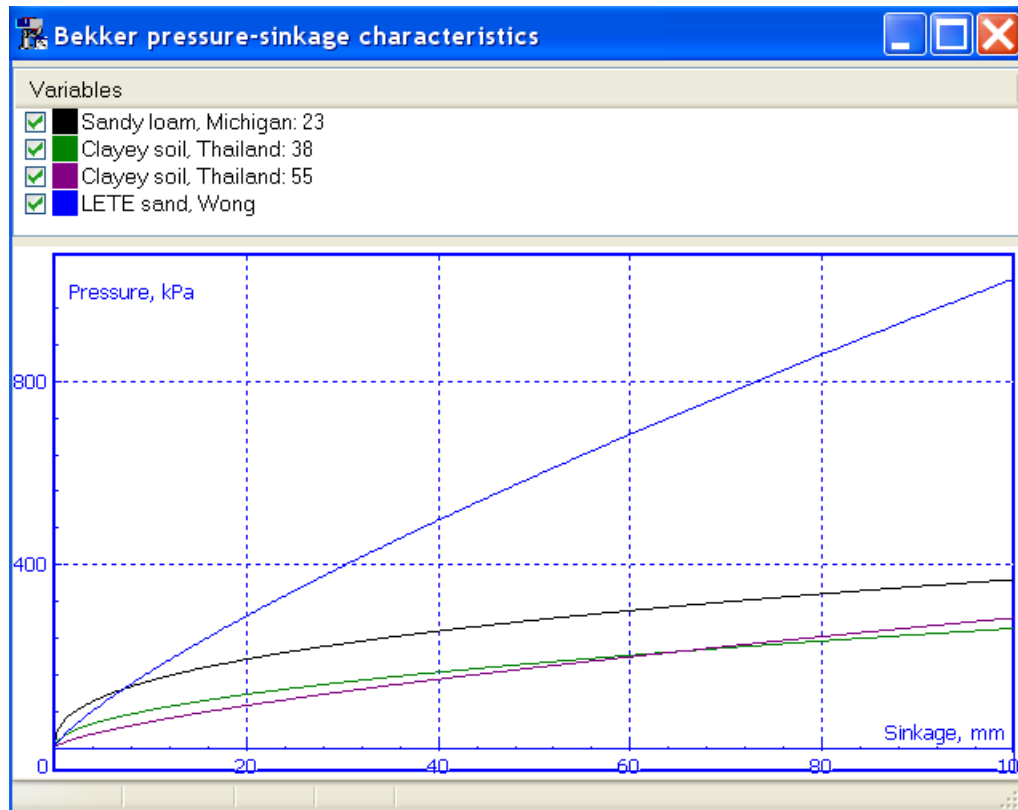

Figure 1.144. Pressure versus sinkage

1.2.1.3. Rolling of wheel on track chain

The following forces are computed by rolling road wheels, idler and rollers on the track chain:

- normal forces;
- friction forces;
- restrictive forces in lateral direction;
- restrictive torques by misalignments.

1.2.1.4. Normal forces in wheel-track interaction

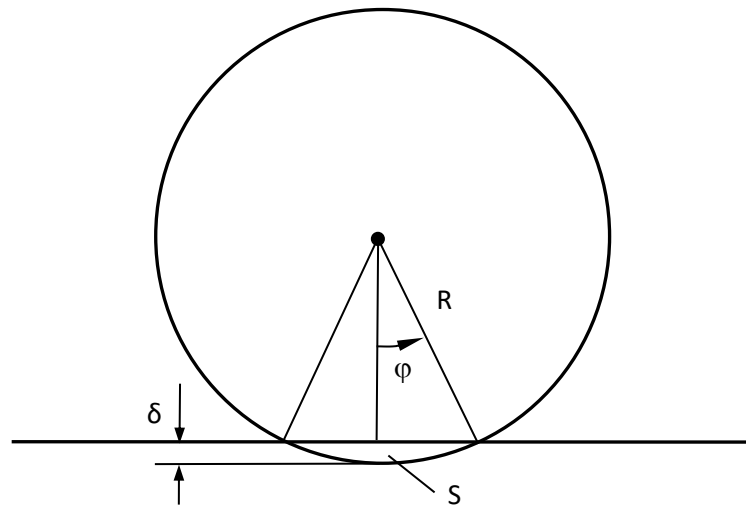

Figure 1.145. Penetration of a wheel into a plane

At the beginning we consider a model of interaction of a flexible wheel with a plane. The main idea: the normal contact force is proportional to the area S of penetration of a ‘rigid wheel rim’ into the plane by vertical displacement of the wheel center δ , Figure 1.145

$$F = \kappa S. \tag{5}$$

where κ is the constant of proportionality characterizing the wheel flexibility. The area S can be expressed in terms of penetration δ or angle φ .

$$S = \frac{2}{3} R^2 \varphi^3, \quad \varphi = \sqrt{\frac{2\delta}{R}}. \tag{6}$$

Substitution of Eq. (6) into Eq. (5) gives the dependence of the force on the penetration

$$F = \frac{2}{3} \kappa R^2 \varphi^3 = \frac{4}{3} \kappa \sqrt{2R} \delta^{3/2}.$$

Note that the exponent factors in this formula and in the Hertz formula for contact of two semispaces are the same, which confirms the correctness of the above assumption.

Let us obtain the dependence of the stiffness factor on the penetration

$$c(\delta) = \frac{dF}{d\delta} = 2\kappa R^2 \varphi^2 \frac{d\varphi}{d\delta} = 2\kappa R \varphi = 2\kappa \sqrt{2R\delta}.$$

The derived formulas allow a simple identification of the model parameters by stiffness c for the given load P or by the deflection δ_0 for the load P

$$\delta_0 = \frac{3P}{2c}, \kappa = \frac{1}{2} \sqrt{\frac{c^3}{3PR}}. \tag{7}$$

The following formulas can be useful as well

$$F = P(\delta/\delta_0)^{3/2}, \quad c(\delta) = \frac{dF}{d\delta} = c(\delta/\delta_0)^{1/2}.$$

Now the obtained relations can be generalized for a contact of a wheel with a polyline corresponding to the track chain.

Let us accept the following assumption: the force is perpendicular to a separate section of the polyline, i.e. to a track link, and proportional to the penetration area under the section.

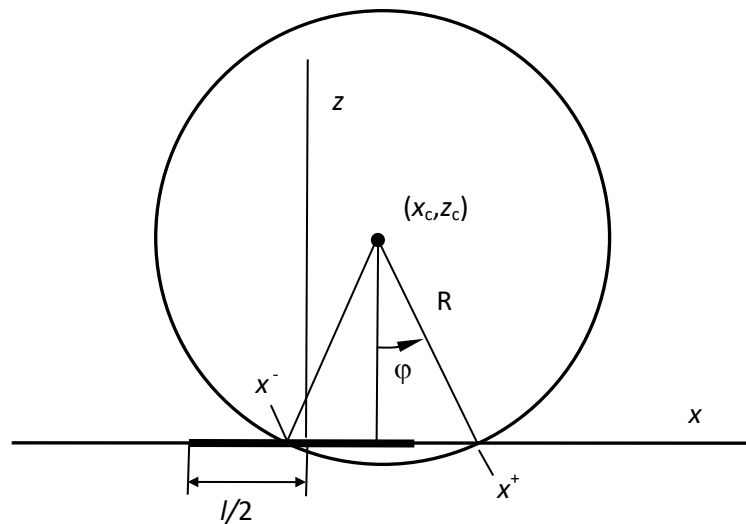

Figure 1.146. Interpenetration of a track link and the wheel

The following formula can be derived in the local system of coordinates of a track link, Figure 1.146

$$x^\pm = x_c \pm R \sin \varphi.$$

Contact conditions are

$$\left\{ x^- < \frac{1}{2} \right\} \cap \left\{ x^+ > -\frac{1}{2} \right\}.$$

It is better to compute the force and moment in SC, which origin is located exactly under the center of the circle.

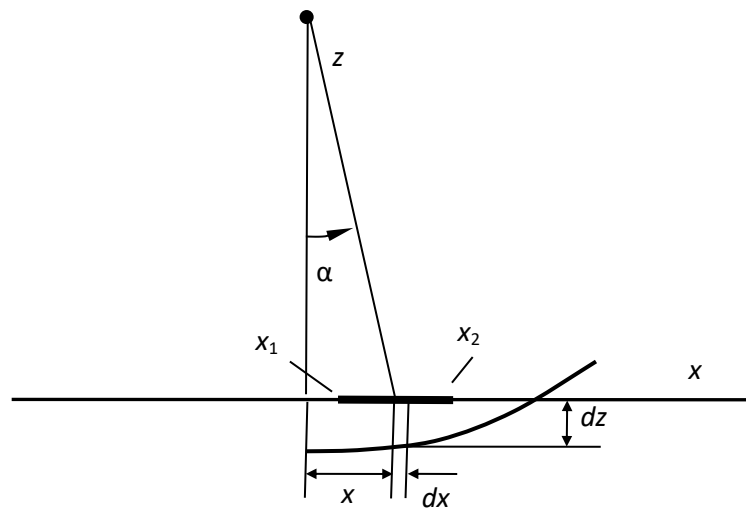

Figure 1.147. Scheme for evaluation of penetration area for a link

Using the circle equation, the formula for penetration versus longitudinal coordinate can be obtained

$$dz = \left| R - \delta - \sqrt{R^2 - x^2} \right| \approx \left| R - \delta - R \left(1 - \frac{x^2}{2R^2} \right) \right| = \delta - \frac{x^2}{2R}.$$

The force is computer as

$$dF = \kappa dx dz,$$

$$F = \kappa \int_{x_1}^{x_2} \left(\delta - \frac{x^2}{2R} \right) dx = \kappa \left(\delta x - \frac{x^3}{6R} \right) \Big|_{x_1}^{x_2},$$

here the limits of the integration interval are

$$x_1 = \max \left\{ -b, -\frac{l}{2} - x_c \right\}, x_2 = \min \left\{ b, \frac{l}{2} - x_c \right\},$$

$$b = \sqrt{2R\delta}.$$

Test: by $-x_1 = x_2 = b$ the above formula for the plane takes place.

To get the application point for the resultant force, the moment relative to the origin of SC must be computed

$$dM = x dF = \kappa x dx dz$$

$$M = \kappa \int_{x_1}^{x_2} \left(\delta x - \frac{x^3}{2R} \right) dx = \kappa \left(\frac{\delta x^2}{2} - \frac{x^4}{8R} \right) \Big|_{x_1}^{x_2}$$

Now, the coordinate for the resultant force is

$$x^* = \frac{M}{F} + x_c.$$

1.2.1.5. Restrictive force and moment

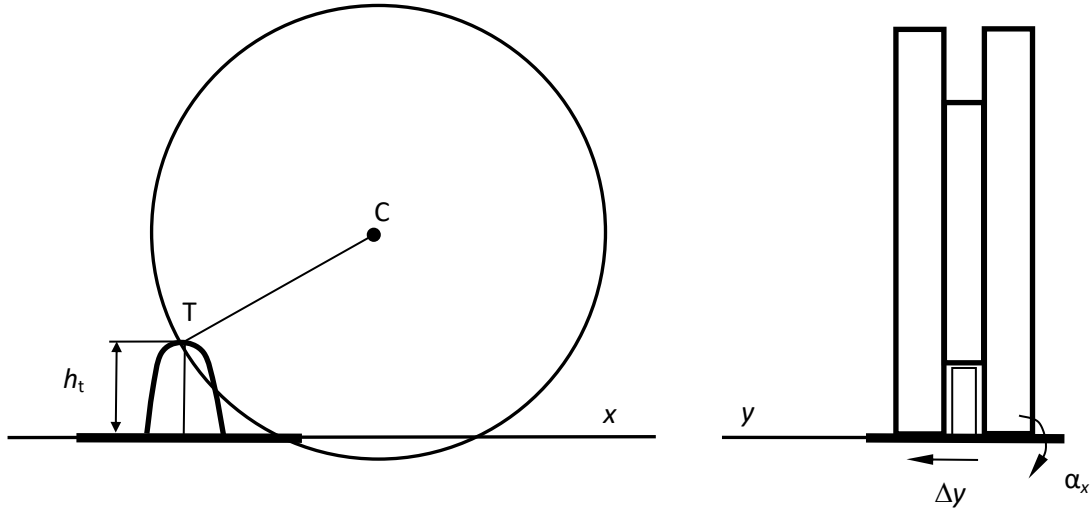

Figure 1.148. Scheme for evaluation of restrictive force and moment

To fix the lateral shift of the track relative to the wheels and rotation about the longitudinal axis, a force and a moment applied to links are introduced

$$\begin{aligned} F_y &= -c_y \Delta y - d_y \Delta \dot{y}, \\ M_x &= -c_{ax} \alpha_x - d_{ax} \omega_x. \end{aligned} \tag{8}$$

Here Δy is the lateral shift of the link relative to the wheel, α_x, ω_x are the relative angle and angular velocity of the link rotation about the longitudinal direction, Figure 1.148; c_y, d_y are the stiffness and damping constants in the lateral direction, c_{ax}, d_{ax} are the angular stiffness and damping constants.

Conditions for initiation of the force and moment is the inequality

$$TC < R,$$

corresponding to the contact between the link tooth and the wheel slot; here T is the top point on the tooth specified by the tooth height h_t , Figure 1.148, R is the wheel radius.

The user must set numerical values for the following parameters: stiffness constant c_y , damping ratio β_y , tooth height h_t (see Sect. 1.2.4.4.1. "Track contact parameters", p. 1-142).

Other parameters are computed according to the formulas

$$d_y = 2\beta_y \sqrt{m_l c_y}, c_{ax} = c_y l^2, d_{ax} = 2\beta_y \sqrt{J_{lx} c_{ay}},$$

where m_l, l, J_{lx} is the track link mass, length and moment of inertia relative to the longitudinal axis.

1.2.1.6. Force for hull locking in horizontal plane

Some tests with the TV model require fixing TV hull in longitudinal and lateral direction as well as by rotation about the vertical axis. In these tests, the linear spring-damper force in the horizontal plane and a torque are applied to the hull

$$\begin{aligned}
 F_x &= -c_{xy}\Delta x - d_{xy}\Delta \dot{x}, \\
 F_y &= -c_{xy}\Delta y - d_{xy}\Delta \dot{y}, \\
 M_Z &= -c_{xy}\gamma - d_{xy}\dot{\gamma}, \\
 d_{xy} &= 2\beta_{xy}\sqrt{m_h c_{xy}}.
 \end{aligned}
 \tag{9}$$

Here $\Delta x, \Delta y$ are deviations of the hull center of gravity in the horizontal plane, γ is the hull rotation about the vertical axis, c_{xy}, d_{xy} are the spring and damper rates, β_{xy} is the damping ratio, m_h is the hull mass.

Stiffness constant c_{yx} and damping ratio β_{xy} are specified by the user, Sect. 1.2.4.4.1. "*Track contact parameters*", p. 1-142.

1.2.1.7. Evaluation of stiffness constant in wheel-track contacts

Two methods can be used for evaluation of road wheel-track contact parameters. According to the first one, the deflection of the wheel center δ_0 under the static load P is used. Value of the stiffness constant is computed by Eq. (7)

$$c = \frac{3 P}{2 \delta_0}.$$

According to the second method, the user must know the stiffness c under the load P directly.

For contacts of the track with idler and rollers, the same values of stiffness parameters can be used because of lower influence of these contacts on dynamics of the TV.

Contact stiffness and damping ratios are specified by the user, Sect. 1.2.4.4.1. "*Track contact parameters*", p. 1-142.

1.2.2. Controlled motion of TV

1.2.2.1. General information about controlled motion of TV

We consider a systematical change of speed or the longitudinal control as well as turning control.

In a case of a simplified model of TV without the driveline, both types of control are realized by the direct support of a desired value of angular velocities of the sprockets. Let v_l, v_r be the current values of the circular speed of the left and right sprocket, which are computed by the formula $v = \omega R_s$, where ω is the angular velocity of the sprocket, and R_s is the sprocket radius on the pin centers. Let V_l, V_r be the desired values of these speeds. The control torque is applied to the sprockets from the TV hull proportionally to the speed differences

$$M_l = -k(\omega_l R_s - V_l), \quad M_r = -k(\omega_r R_s - V_r),$$

where k is the amplification.

When the TV moves on a straight section of road, the desired speeds V_l, V_r are equal and specified by the user as a plot of the longitudinal speed versus the time or distance (TV travel)

$$V_l = V_r = \begin{cases} V(t), t - \text{time}, \\ V(s), s - \text{distance}. \end{cases}$$

A difference of the right and left sprocket speeds is implemented for the TV turning

$$\Delta V = V_r - V_l.$$

A positive difference corresponds to the left turn, while a negative related to the right one.

Two methods are implemented to turn TV, which we will designate as a *symmetric* turning and a *unilateral* one. In the case of a symmetric turn, the sprocket speed increases on $\frac{\Delta V}{2}$ for the outer track and decreases on the same value for the inner track, i.e.

$$V_l = V - \Delta V/2, \quad V_r = V + \Delta V/2,$$

where V is the desired longitudinal speed. Such the control corresponds to a differential gear as a turning mechanism.

In the case of a unilateral turn, the sprocket speed is constant for the outer track and decreases on ΔV for the inner one,

$$V_l = \begin{cases} V - \Delta V, \Delta V > 0, \\ V, \Delta V < 0, \end{cases}$$

$$V_r = \begin{cases} V, \Delta V > 0, \\ V + \Delta V, \Delta V < 0. \end{cases}$$

This case corresponds e.g. to a simplified model of a side clutch.

The value ΔV specifies the turning radius and can be set by the user as an explicit function of the time or the distance, which corresponds to an open loop turning control, Sect. 1.2.4.3. "*Tools tab: setting speed history*", p. 1-140, Sect. 1.2.4.5.6.2. "*Test: open loop steering*", p. 1-167. In another case this value is evaluated by the driver model and allows automatic motion along given routes, Sect. 1.2.4.5.6.3. "*Test with driver*", p. 1-168.

1.2.2.2. Driver model

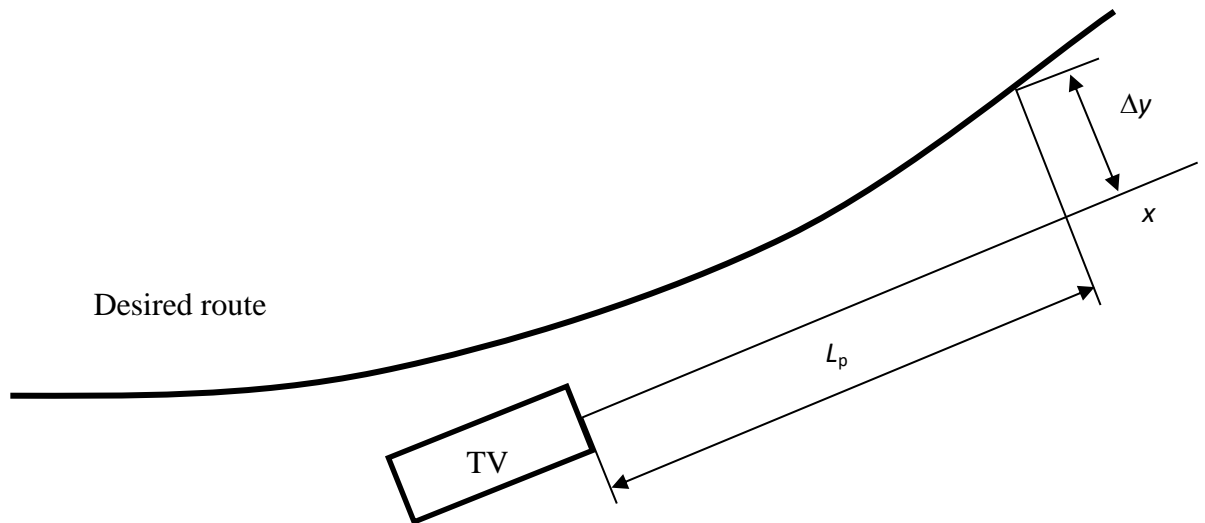

Figure 1.149. To the driver model

Consider the driver model implemented in UM. Let the desired path (route) is given, Figure 1.149. The internal ‘driver’ must follow it. The control with the closed loop or the driver model is as follows: at the moment t the driver assesses the deviation $\Delta y(t)$ from the route a point located straight ahead on a preview distance $L_p = T_p v_x$. Here $T_p v_x$ are the preview time, specified by the user, and the vehicle speed. The control is

$$\Delta V = K \Delta y(t - t_d),$$

where K is the gain, t_d is the reaction time delay.

Table 1.21

Parameters of driver model

Parameter	Comments	Recommended interval of values	Default value
T_p	Preview time	1-2s	1s
t_d	Reaction time delay	>0.1s	0.1s
K	Gain	3-6	4

Numeric values of the control parameters depend on the speed, route, and TV, Table 1.21. The user should run several simulations with different values of the parameters to get a stable and reliable control.

1.2.2.3. Geometry of controlled motion of TV

1.2.2.3.1. Straight motion

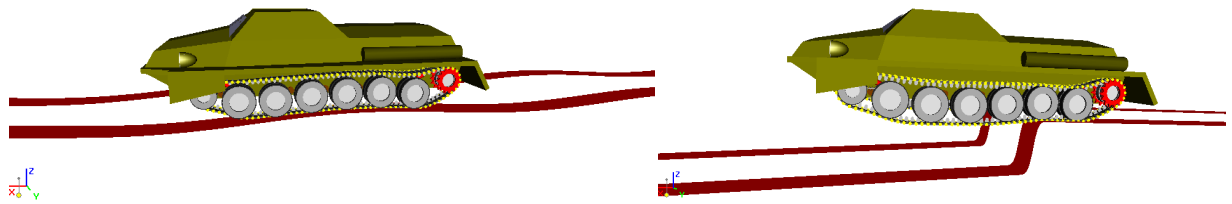

Figure 1.150. Examples of vertical geometry by straight motion of TV

The driver model is not used for this type of motion, because circular speeds of sprockets are equal. Vertical irregularities and obstacles can be assigned.

1.2.2.3.2. Plane curve

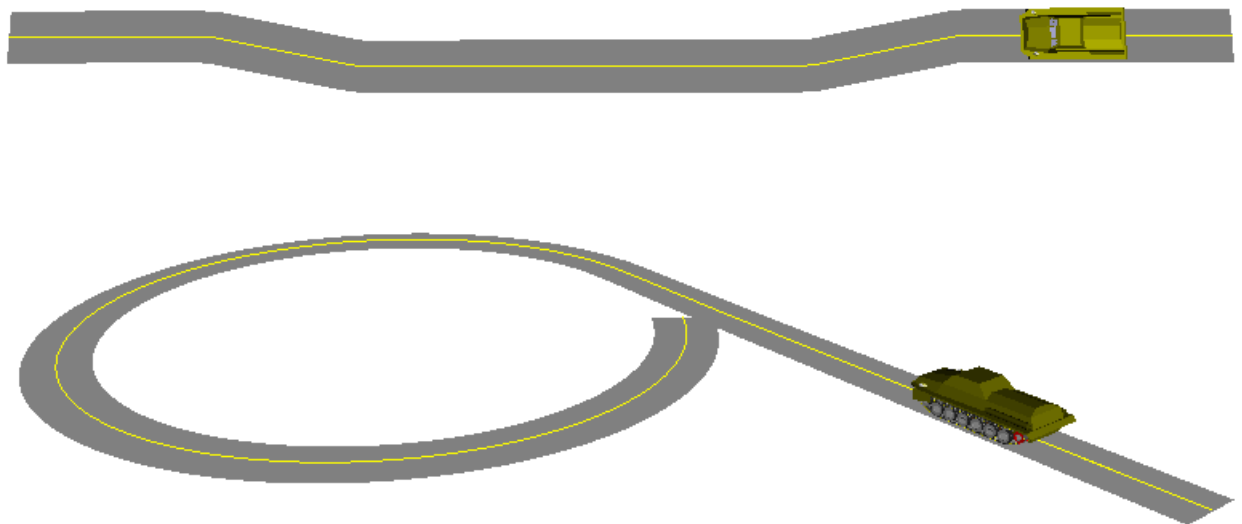



Figure 1.151. Examples of paths for controlled motion with driver

The user specifies a plane curve as a desired path for the TV motion with the driver model. Vertical irregularities can be assigned.

A curve editor is used for development of paths. The **Tools | Create macrogeometry...** menu command calls the window, Figure 1.152. The desired path is created in the curve editor by the  button.

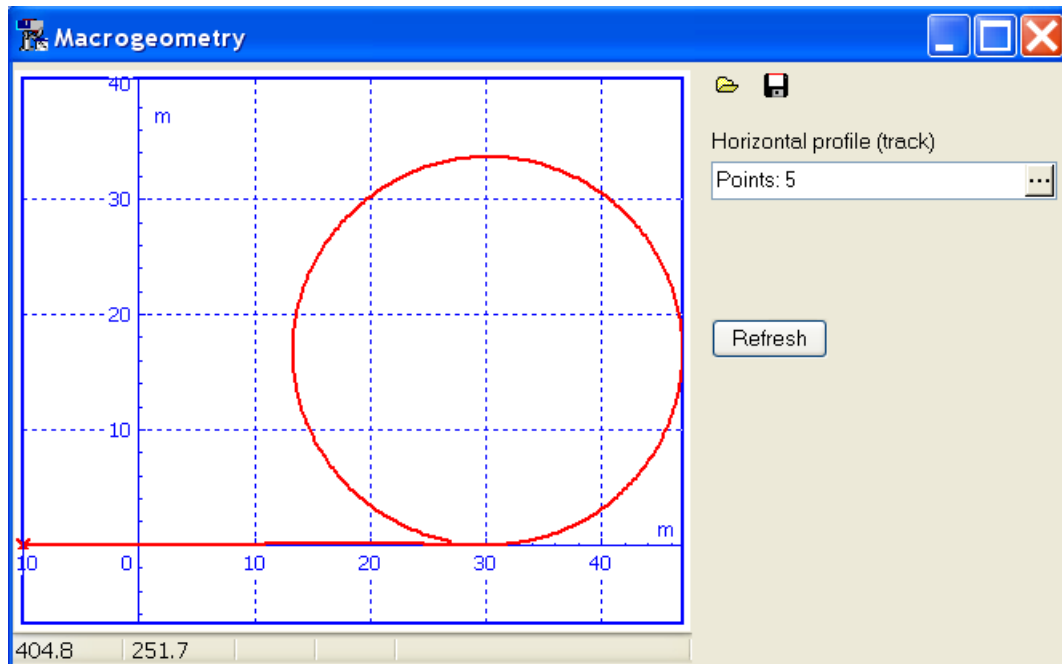

Figure 1.152. Tool for development of the TV paths

1.2.2.3.3. Testing area

A testing area is a surface with a set of testing obstacles. The TV model overcomes the obstacles following to a route defined by the user. The image of a testing area is created in the UM Input program or in one of the CAD programs and imported to UM format in the standard manner. The image must should be saved in a *.img file. The UM database of testing areas contains two of them:

- {UM Data}\Caterpillar\TestingArea\TestingArea.img (Figure 1.153);
- {UM Data}\Caterpillar\TestingArea\SandPit.img.

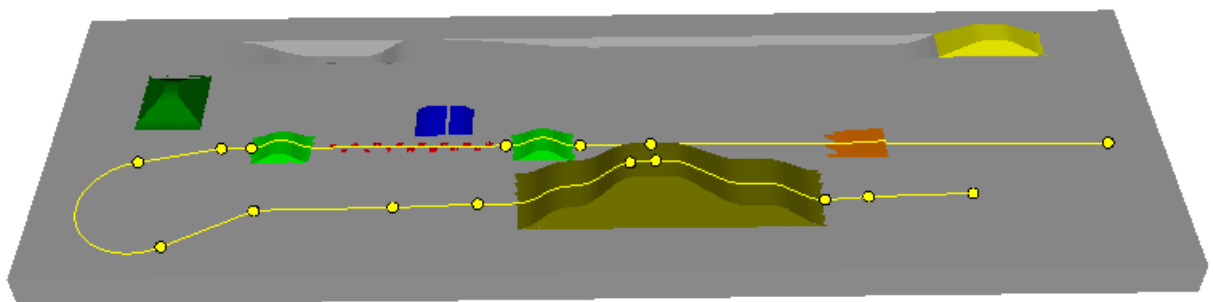

Figure 1.153. Example of a testing area and a route

Please note that not all graphic objects can be used for a testing area. The following list of requirements should be met.

- The *.img file should contain the only graphic objects. Particularly it means that a graphic object for a testing area should not include graphic elements of "Graphic object" type. It is a referential type of graphic elements. Initial graphic objects are saved separately in the same *.img file that leads to more than one graphic object in the *.img file.

- All geometry of graphic elements should be expressed via numerical constants without using identifiers. Parameterization is not allowed. File *.img should not include sections with the identifiers.

If a graphic object does not satisfy the requirements for testing areas then you will see the following error message:

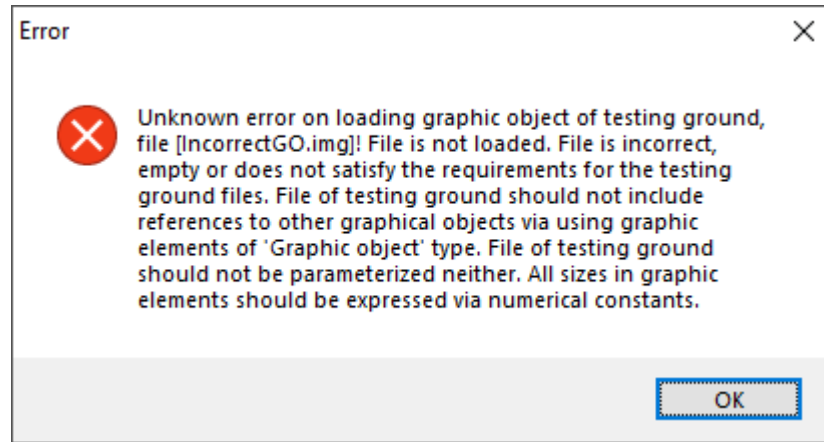

Figure 1.154. Error on loading a graphic object as a testing area

The user creates a set of routes for a testing area. Motion of TV along a route with a definite variable speed is controlled by the driver model. Features of creating routes for testing areas are described in Sect. 1.2.4.1.3.1 "*Routes on testing area*", p. 1-133. Micro irregularities can be taken into account along with the obstacles.

1.2.3. Classification of dynamic tests

Simulation of TV dynamics in UM is based on a system of tests. Here is the current list of available tests:

1. equilibrium,
2. track tension,
3. tension by joint preload,
4. computation of initial velocities,
5. vertical harmonic loading,
6. straight motion,
7. open loop steering,
8. test with driver.

The tests can be divided into two groups: auxiliary (1-5) and main test (6-8). Auxiliary tests are used for computation of initial state of TV and for preparing the main tests. The main tests are used for analysis of dynamic properties of TV.

TV is fixed in longitudinal direction in tests 1-5. Tests 6-8 allow evaluation of dynamic performances by motion taking into account ground profile and irregularities.

It is recommended to run the tests in the above sequence.

1.2.4. Preparing TV for simulation

Before start the tests, the user must do definite steps to prepare the TV model. With this purpose, the **Tracked vehicle** tab of the object simulation inspector is used.

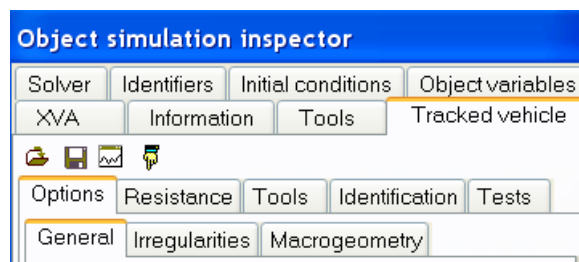





Figure 1.155. Object simulation inspector



Load the TV model in UMSimul program. Call the simulation inspector by the **Analysis | Simulation** menu command, Figure 1.155. The button  on the tool panel as well as the **F9** key can be used as well.

Remark. The inspector contains several useful general purpose tabs: Identifiers, Solver, Initial conditions, Tools, Object variables, see [Chapter 4](#) “UM Simulation program”, Sect. *Integration of equations of motion (single mode) | Preparing for integration.*

Consider a list of main control elements on the **Tracked vehicle** tab.

Button  is used for saving the TV parameters and options specified by the user on the tab, file with configuration of TV is *.tvc.

Button  reads parameters of TV from a previously created configuration file *.tvc.

Button  shows current irregularities for the left and right tracks in a graphic window, Sect. 1.2.4.1.2.4. "Examples of irregularities", p. 1-130. The same action is assigned to the  button on the main tool panel.

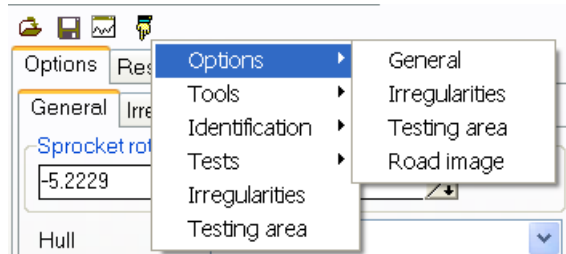

Figure 1.156. Menu of quick access

Button  organizes a quick access to different tabs and parameters, Figure 1.156.

The **Options** tab: setting some parameters of TV and operation conditions such as track tension parameter, ground irregularities, assigning a testing area, etc., Sect. 1.2.4.1. "Options tab", p. 1-128.

The **Resistance** tab allows specification of aerodynamic drag, Sect. 1.2.4.2. "Resistance tab", p. 1-139.

The **Tools** tab: creation of TV speed dependences on time or distance, Sect. 1.2.4.3. "Tools tab: setting speed history", p. 1-140.

The **Identification** tab: specification of auxiliary parameters for dynamic tests such as contact parameters, blocking force parameters, specification of identifiers for sprocket torques, soil parameters, Sect. 0.

The **Tests** tab is used for selection of a current test and definition of its parameters.

1.2.4.1. Options tab



Figure 1.157. Elements of Options tab

TV options tab contains tree elements:

- General options,
- Irregularities for each of the track,
- Macrogeometry parameters.

1.2.4.1.1. General options

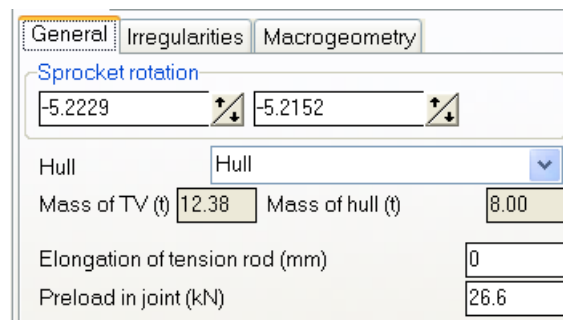

Figure 1.158. General options

The **General** tab allows the user to set the following parameters, Figure 1.158.

1. Initial rotation angles of sprockets.
2. A body in the model as the hull of TV. Program assigns the body with the maximal mass, but the user may correct this assignment if necessary.
3. Elongation of the tension device and/or preload in the track link joints (bushings) to get the desired tension of tracks. Numeric values of these parameters are evaluated in the tests Track tension (Sect. 1.2.4.5.2. "*Test: track tension*", p. 1-150) and Tension by preload (Sect. 1.2.4.5.3. "*Test: tension by preload*", p. 1-155).

1.2.4.1.2. Irregularities

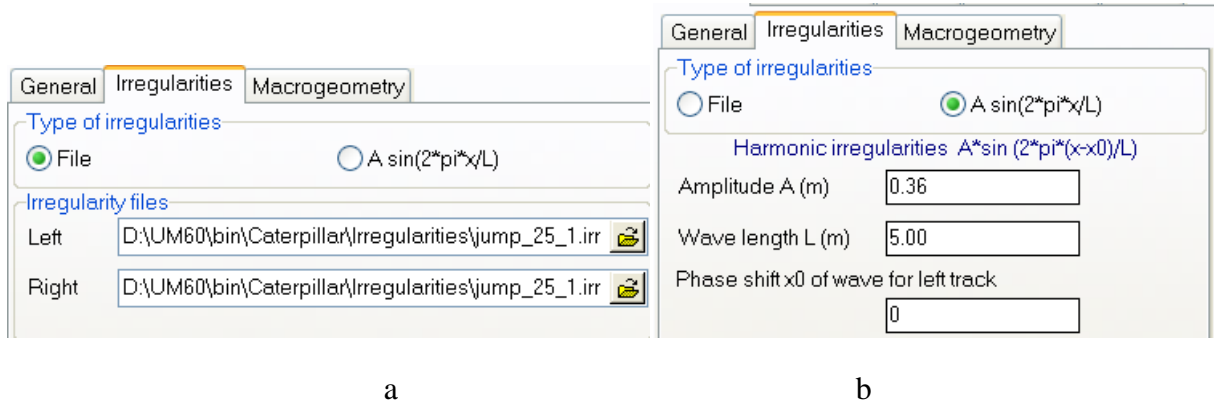

Figure 1.159. File (a) and harmonic (b) irregularities

In the main tests, Sect. 1.2.3. "Classification of dynamic tests", p. 1-126, irregularities can be assigned both for the left and right tracks, Figure 1.159.

1.2.4.1.2.1. File with irregularities

Text files *.irr contain vertical ground irregularities for the left or right track of TV.

File format. File with irregularities contains two columns. The first column contains the longitudinal coordinate (distance) in meters starting from 0. The second one corresponds to the vertical coordinates of the ground in meters. Example:

```

0 -0.00540956
0.1 -0.00553727
0.2 -0.00564776
0.3 -0.00574484
0.4 -0.00583378
0.5 -0.00592044
0.6 -0.00601059
0.7 -0.00610933
    
```

Creating irregularity files. A special tool can be used for creating irregularities. This tool was initially developed for description of rail irregularities. Use the **Tools | Create irregularities...** or the  button on the tool panel.

Detailed information about the tool can be found in the user's manual, [Chapter 12](#), Sect. *Generation of irregularity files*, and [Chapter 8](#), Sect. *Creation of files with irregularities*.

File locations. Standard irregularity files are located in the directory **{UM Data}\Caterpillar\Irregularities**.

It is recommended to save user's files either in this directory or in the directory of the modeled TV.

Assignment of irregularity files. Click the button  to select a file, Figure 1.159a.

1.2.4.1.2.2. Harmonic irregularities

In this case, the vertical ground profile is computed by the formula

$$z = a \sin \frac{2\pi}{L}(x - x_0),$$

where a is the amplitude, L is the wave length (a period), x is the longitudinal coordinate, x_0 is the phase shift for the right track.

1.2.4.1.2.3. Smooth run on irregularities by start

To avoid a jump in forces by run on irregularities at the initial stage of motion, the irregularities are set to zero at the first five meters of the running distance, and a smoothing is used.

In the case of harmonic irregularities, the smoothing is made from 5 to 15 meters by a square function with the growth from 0 to 1, i.e. the function is multiplied by the factor $(x-5)^2/100$.

In the case of file irregularities, the smoothing is made from 5 to 10 meters by a linear function, i.e. the irregularity is multiplied by the factor $(x-5)/5$. For example, consider a file irregularity of the constant height 100mm. The smoothed irregularity, which is used in simulations, is shown in Figure 1.160.

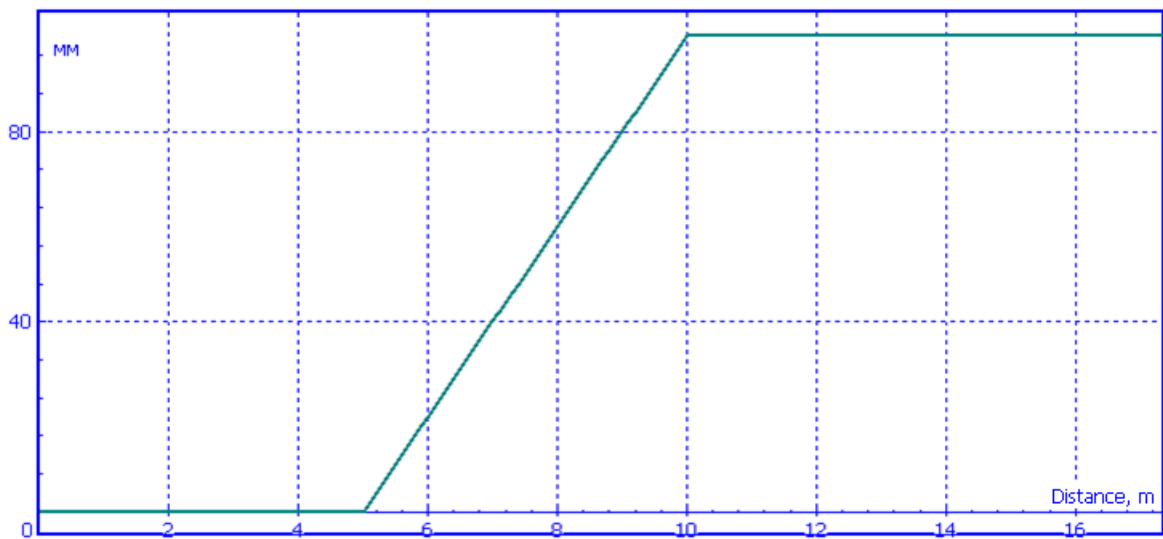



Figure 1.160. Smoothed ground profile

1.2.4.1.2.4. Examples of irregularities

After entering irregularity parameters, the plot can be obtained by the  button. Figure 1.161 shows an example of a sinusoidal ground profile for the parameter values

$A=100\text{mm}$, $L=8\text{m}$, $x_0=2\text{m}$.

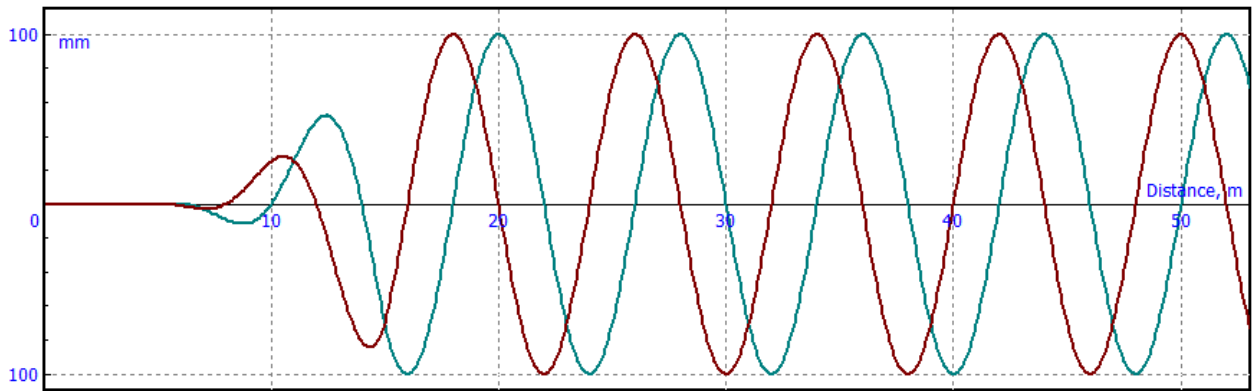

Figure 1.161. Example of sinusoidal profile

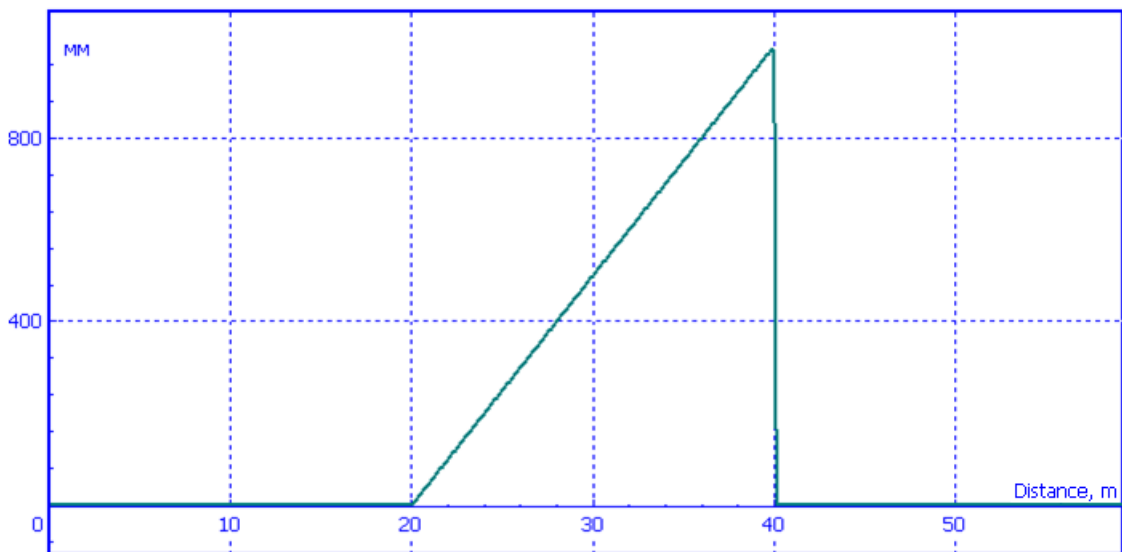

Figure 1.162. Example of ground profile from file

An example of the ground profile for simulation of TV jump is shown in Figure 1.162.

1.2.4.1.2.5. Visualization of road

By straight motion of TV, strips of road with irregularities are drawn for the left and right tracks. Figure 1.163 shows animation windows with ground profiles corresponding to irregularities in Figure 1.161, Figure 1.162.

Width and color of the strips can be set in the **Macrogeometry** tab, Sect. 1.2.4.1.2.5. "*Visualization of road*", p. 1-131.

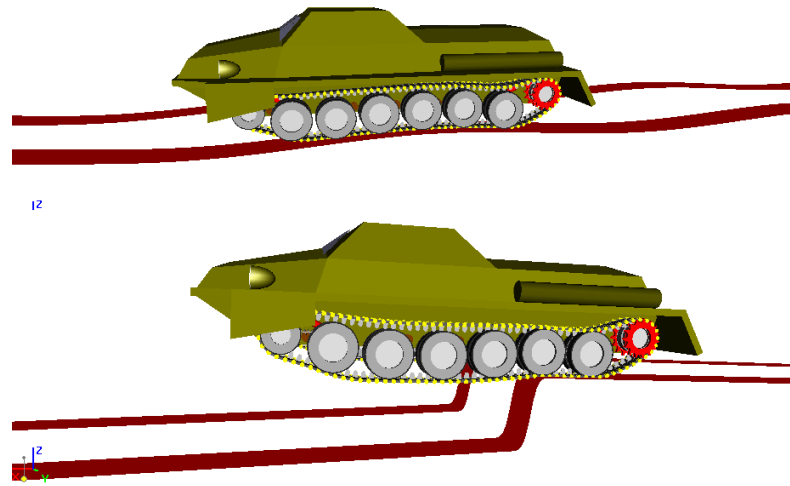



Figure 1.163. Examples of irregularities

1.2.4.1.3. Parameters of macrogeometry

1.2.4.1.3.1. Routes on testing area

Assignment of testing area (TA)

Use the  button in Figure 1.171 to select a file *.img with the TA image. Requirements for graphic objects for testing areas are described in Sect. 1.2.2.3.3 "Testing area", p. 1-124.

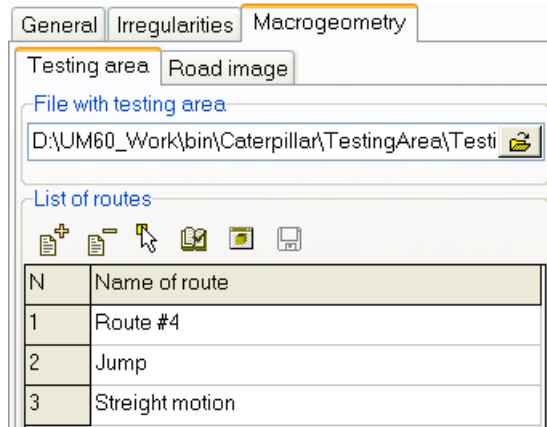



Figure 1.164. Parameters of TA

Creating and editing of routes

A route is a curve created by the user on a TA. The TV model follows the assigned route on the TA under control of the driver model, Sect. 1.2.2.2. "Driver model", p. 1-122, Sect. 1.2.2.3.3. "Testing area", p. 1-124.

The following tools are available of the tab.

 Adding a new route to the list of routes

 Deleting a route from the list

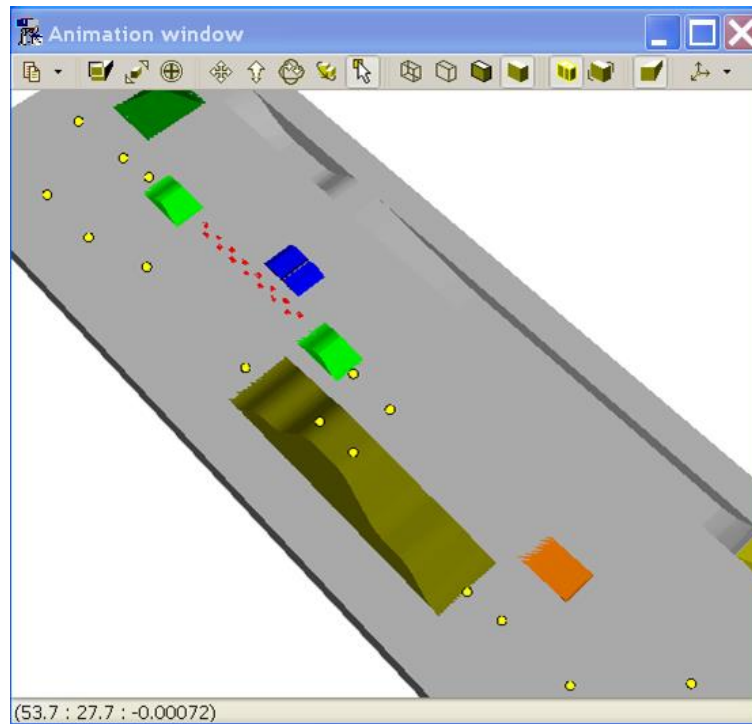

Figure 1.165. Setting route markers

 *Adding a new route and start the mode for the visual creating a route by the mouse*

After click on this button, the animation window with the TA image appears. The user creates here a sequence of markers (key points) on the route, Figure 1.165. The following recommendations are important.

- The first and the second markers should be located on a horizontal part of the TA. These points set the initial position of the TV on the TA by a shift and rotation of the TA so that the origin of SC0 coincides with the first marker, and the X-axis passes through the second one, Figure 1.166.

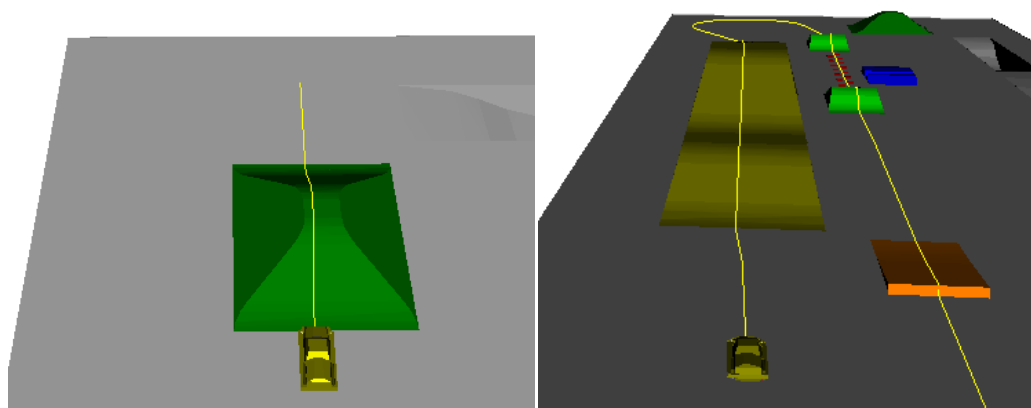

Figure 1.166. Examples of initial positions of TV for different routes

- Markers a set in positions corresponding to changes of directions of motion (start and end points of the TV turnings) as well as in positions where it is planned to change the TV speed, Figure 1.167.

- After end of selection of the markers, close the window and confirm the acceptance of data input.

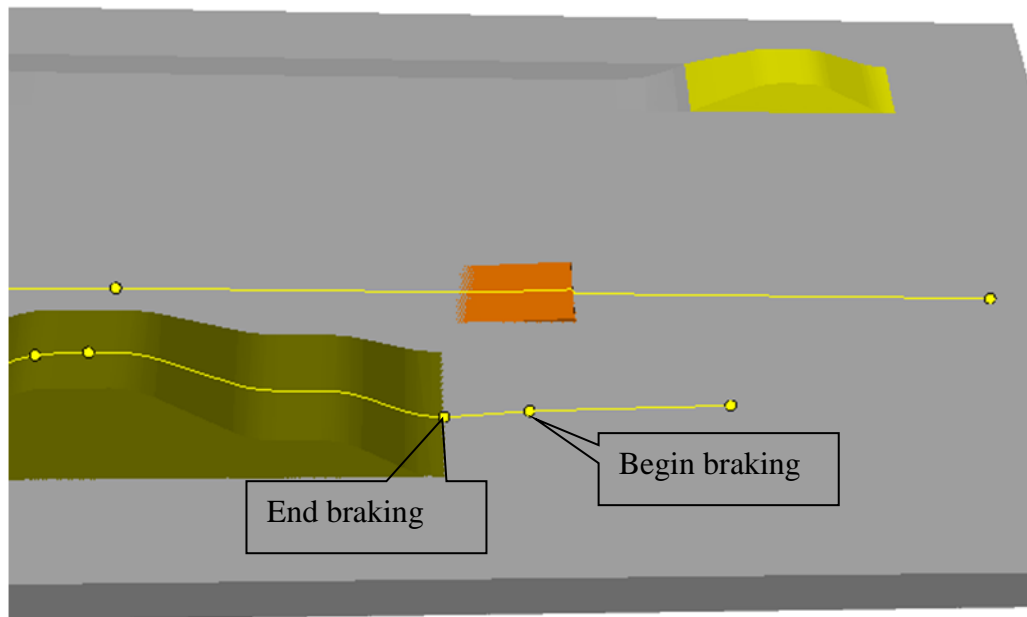

Figure 1.167. Markers specify the interval of the braking process

Correcting routes in the curve editor

After the click on this button, the curve editor appears containing all the routes, Figure 1.168. It is necessary to check one route curve, which is to be modified. Uncheck all other curves.

In the editor, the user can

- correct coordinates of points;
- add and delete any number of points;
- smooth some section by circles and splines, Figure 1.169.

Detailed information on the curve editor can be found in [Chapter 3](#) of the user's manual, Sect. *Curve editor*.

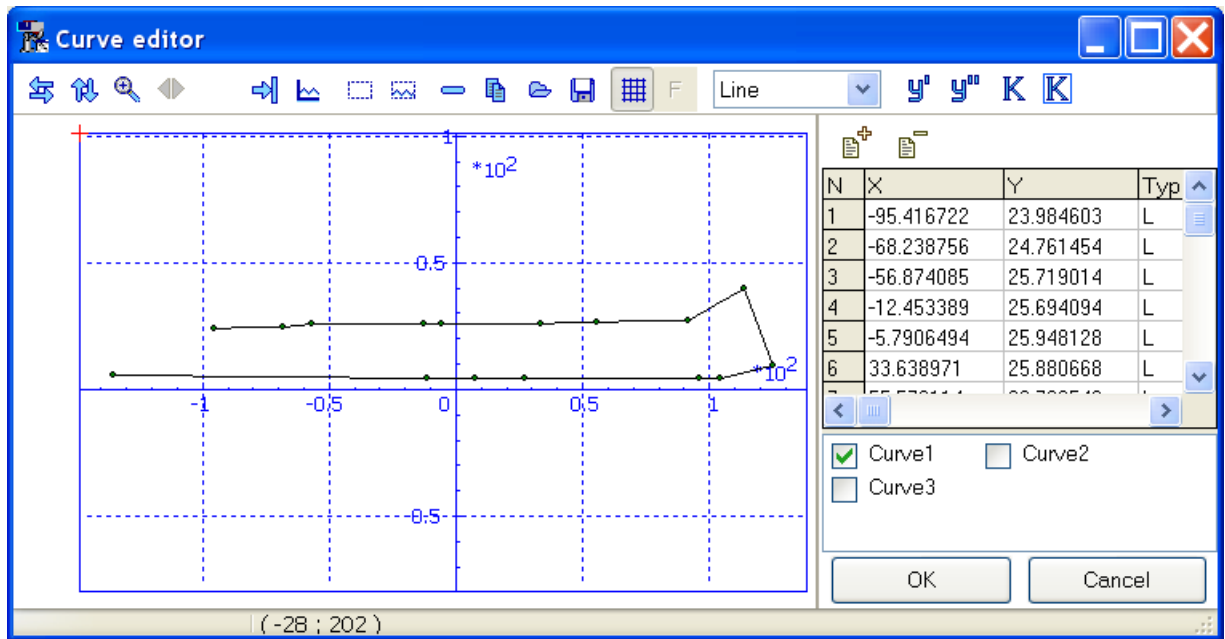

Figure 1.168. Routes in the curve editor. All routes except the checked one, are hidden

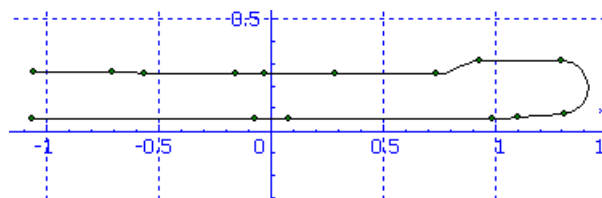



Figure 1.169. Route after editing

 *View of route in animation window*

Select a route in the list and click this button. An animation window with TA image and the route appears. If the mouse cursor points to a route marker, coordinates of the marker and the distance *S* to it along the route can be found in the window status bar, Figure 1.170.

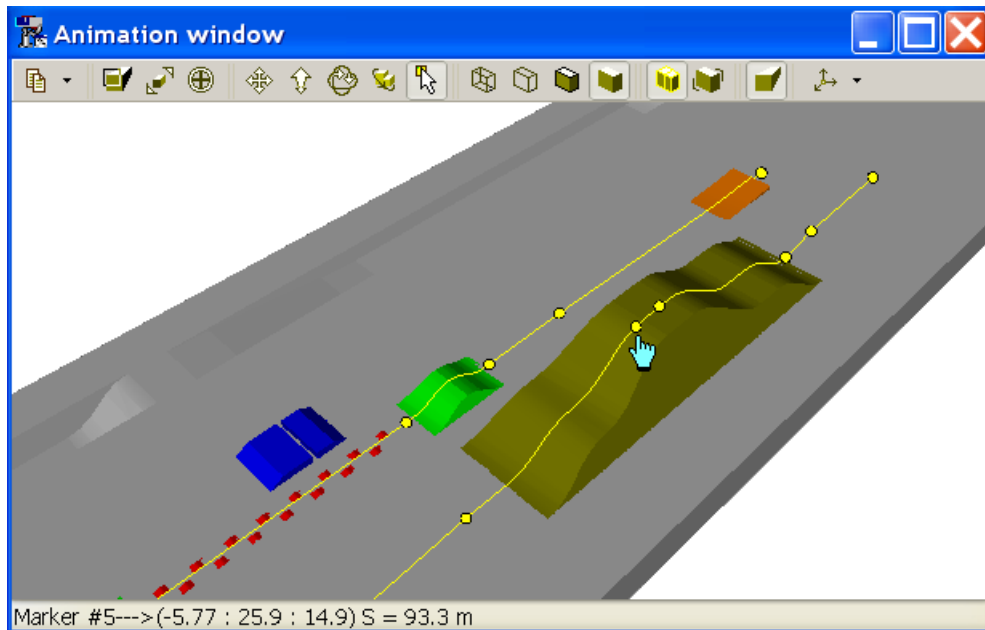



Figure 1.170. Route in animation window

 *Save the route list to file*

The routes are saved in a text file *.rt; name of the file is the name of the TA. The file is stored in the same directory as the TA file. For instance, the route file for the TA

{UM Data}\Caterpillar\TestingArea\TestingArea.img
will be saved as

{UM Data}\Caterpillar\TestingArea\TestingArea.rt.

1.2.4.1.3.2. Parameters of the road image

On the **Macrogeometry** tab, the user can change parameters of visualization of the road strips, Figure 1.171, Sect. 1.2.4.1.2.5. "Visualization of road", p. 1-131:

- strip width;
- discretization step in longitudinal direction;
- color.

For the tests with driver by motion on 2D curve:

- road width.

For the test with driver:

- line color for the route, Figure 1.166.

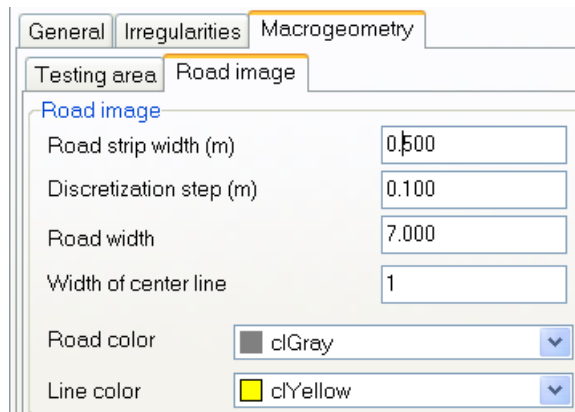
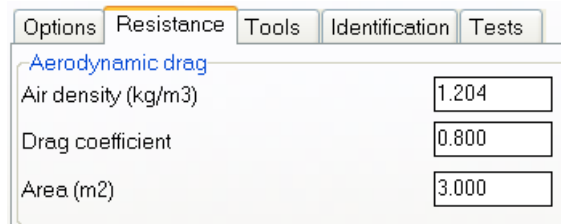

Figure 1.171. Parameters of road image

1.2.4.2. Resistance tab

Resistance	
Aerodynamic drag	
Air density (kg/m3)	1.204
Drag coefficient	0.800
Area (m2)	3.000

Figure 1.172. Parameters of resistance

Aerodynamic drag is specified by three parameters:

- air density ρ ,
- drag coefficient c_W ,
- area of TV projection on the plane perpendicular the TV axis (A).

The force is computed by the formula

$$W = c_W A (\rho/2) v^2,$$

where v is the TV speed.

1.2.4.3. Tools tab: setting speed history

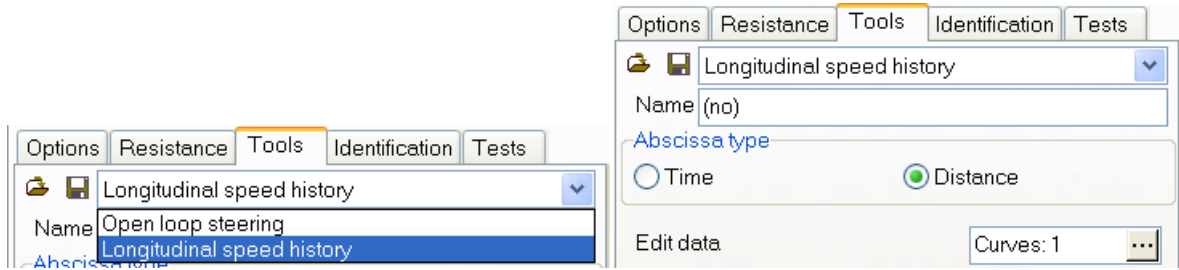



Figure 1.173. Tool for speed history

The **Tools** tab is used for creation of speed history files

- desired track speed difference ΔV for open loop steering test,
- desired longitudinal speed V for tests with longitudinal motion.

The speed curve can be a function of either time or distance.

To create the speed history, call the curve editor by the  button and define a curve as a sequence of points. An example of a speed vs. time curve is shown in Figure 1.174. Here the speed increases with a constant acceleration from 0 to 10 m/s, and then the speed is constant.

Remark. By specifying the speed versus distance curve, the initial speed cannot be zero.

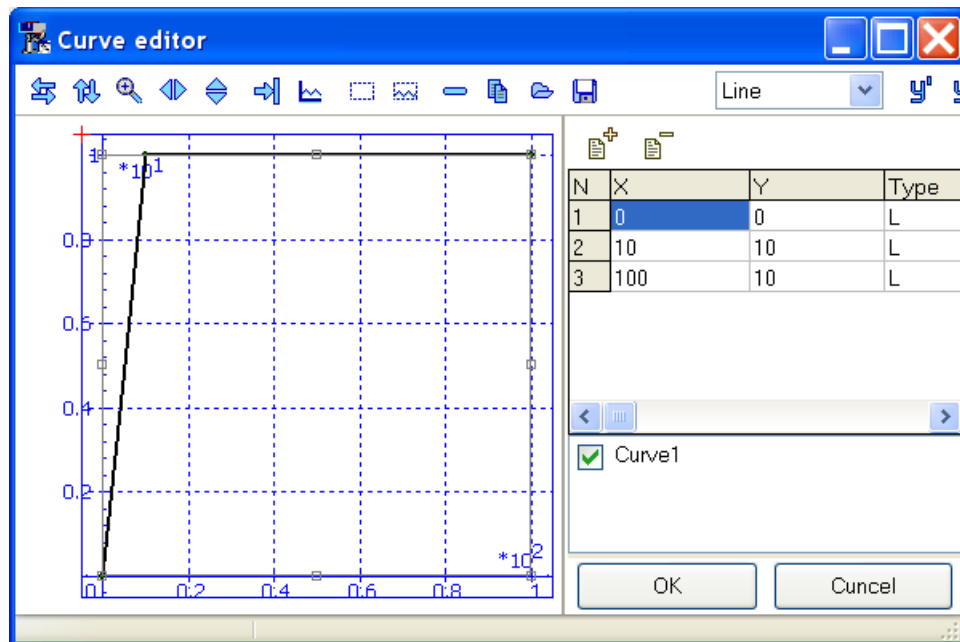

Figure 1.174. Speed vs. time

1.2.4.4. Identification tab

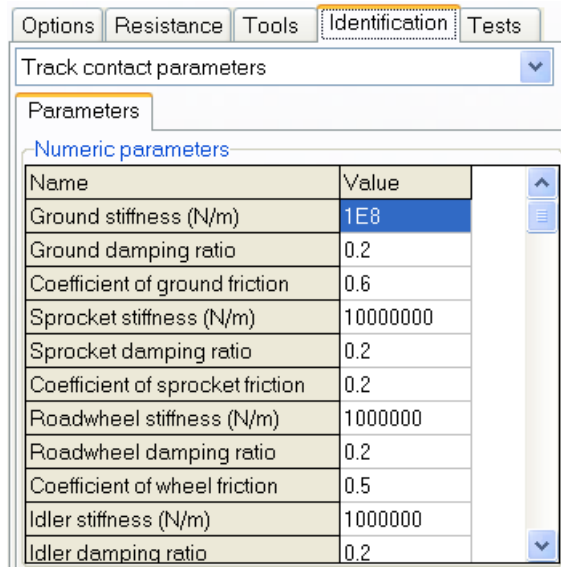

Figure 1.175. Identification of TV model parameters

The following parameters are specified on the Identification tab (Figure 1.175):

- track contact parameters,
- locking parameters for hull horizontal motion,
- identification of drive torques applied to sprockets,
- terrain parameters.

1.2.4.4.1. Track contact parameters

Table 1.22

Contact parameters

Parameter	Default value	Comments
Ground stiffness (N/m)	1.0e8	Sect. 1.2.1.2. <i>"Track-ground interaction"</i> , p. 1-112.
Ground damping ratio	0.2	
Coefficient of ground friction	0.3	
Sprocket stiffness (N/m)	1.0e7	Sect. 1.2.1.1. <i>"Sprocket-pin interaction"</i> , p. 1-111.
Sprocket damping ratio	0.2	
Coefficient of sprocket friction	0.2	
Road wheel stiffness (N/m)	1.0e6	Sect. 1.2.1.7. <i>"Evaluation of stiffness constant in wheel-track contacts"</i> , p. 1-120.
Road wheel damping ratio	0.2	
Coefficient of wheel friction	0.5	
Idler stiffness (N/m)	1.0e6	
Idler damping ratio	0.2	
Roller stiffness (N/m)	1.0e6	
Roller damping ratio	0.2	Sect. 1.2.1.5. <i>"Restrictive force and moment"</i> , p. 1-119.
Lateral stiffness (N/m)	1.0e8	
Lateral damping ratio	0.2	
Guide tooth height (mm)	100	Maximal vertical travel of track links relative to the hull. Ignored if value is greater than 10000. For instance, the contact is ignored for the default parameter value
Max. track Z travel (mm)	100000	

Parameters of contact of track with ground and wheels are set in the table, Figure 1.175, Table 1.22, Sect. 1.2.1. *"Models of force interactions"*, p. 1-111.

Remark. Damping ratios β in Table 1.22 are used for computation of damping constants d by the stiffness constant c and body mass m as

$$d = 2\beta\sqrt{mc}$$

As a rule the smallest mass m of the contacting bodies is used in this expression.

1.2.4.4.2. Hull locking parameters

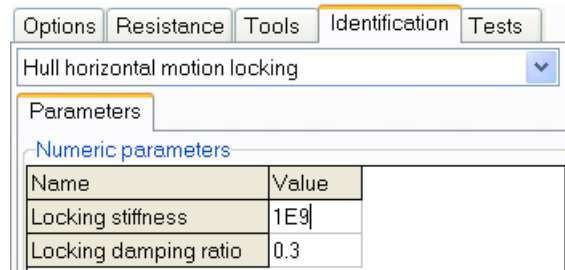

Figure 1.176. Hull locking

Locking is used in some tests for fixing the hull motion in the horizontal plane. Stiffness constant as well as the damping ratio are set in the table, Sect. 1.2.1.6. *"Force for hull locking in horizontal plane"*, p. 1-119.

1.2.4.4.3. Traction torques

Identifiers of traction torques must be selected in the table, Sect. 1.1.1.4.3.4. "Template of sprocket", p. 1-51, Table 1.14. If the standard identifier *traction_torque* is used, this assignment is done automatically.

If the user renamed the identifier in the sprocket template, he must select the corresponding identifiers from the list after the double click on the table cell in Figure 1.177.

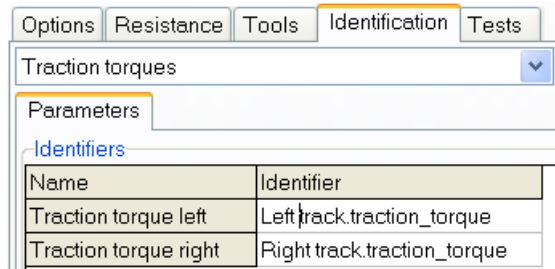

Figure 1.177. Identifiers of traction torques

1.2.4.4.4. Terrain parameters

The screenshot shows a software interface for setting terrain parameters. At the top, there is a dropdown menu labeled 'Terrain parameters' with a blue arrow pointing to a second dropdown menu. The second dropdown menu is open, showing a list of soil types: 'Dry sand, LLL', 'LETE sand, Wong', 'Sandy loam, LLL: 15', 'Sandy loam, LLL: 22', 'Sandy loam, Michigan: 11', 'Sandy loam, Michigan: 23', 'Sandy loam, Hanamoto: 26', and 'Sandy loam, Hanamoto: 32'. Below this, the 'Name' field is set to 'Heavy clay'. Underneath, there is a section titled 'Parameters' with a sub-section 'Numeric parameters' containing a table of parameters and their values.

Name	Value
Exponent of deformation	0.79000002
Cohesive modulus	102
Friction modulus	5301
Factor of cohesion	1.3
Angle of resistance (deg)	31.1
Shear elasticity constant K (mm)	11.3
Re- unloading constant k0 (kPa/m)	0
Re- unloading constant Au (kPa/m^2)	86000

Figure 1.178. Terrain parameters

In the case of the main tests, ground with sinkage model can be applied, Sect. 1.2.1.2.2. "Bekker ground model", p. 1-113. Parameters can be set directly into the table in Figure 1.178, or assigned from the database with the help of the drop-down list.

1.2.4.5. Tests tab

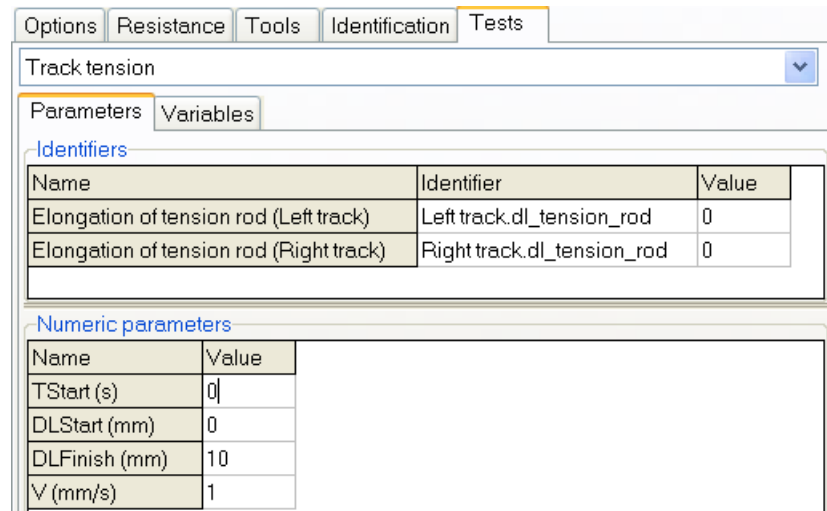

a



b

Figure 1.179. Example of test parameters (a) and list of tests (b)

Before run the simulation with a TV model, the user must select one of the available tests from the list in Figure 1.179 and initialize necessary parameters related to the test.

Two types of parameters can be related to a test (**Parameters** tab in Figure 1.179):

- *Identifiers*; the initialization in this case consists in assignment of identifiers from the TV model; it is recommended to use the standard identifier names by development of TV models: in this case the assignment will be done automatically;
- *Numeric parameters*; the user set desired values of these parameters.

A list of standard test variables is available for the most of the tests on the **Variables** tab in Figure 1.179. The user can get plots of these variables if he drags them into a graphic window before simulation.

1.2.4.5.1. Test: Equilibrium

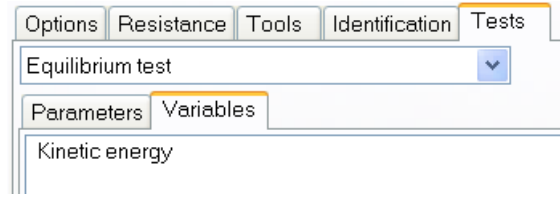

Figure 1.180. Standard variable of equilibrium test

Test objective.

This is an auxiliary test intended for finding coordinates of bodies in the TV equilibrium state. The test is necessary because positions of bodies in the TV model after its development in the **UM Input** are specified approximately, Figure 1.181. Thus, intensive transient processes take place by the start of simulation. The test is used to remove these transients. As a rule, this is the first test with a new TV model or after change of inertia or suspension parameters.

Remark. Ground friction is automatically set to zero during this test.

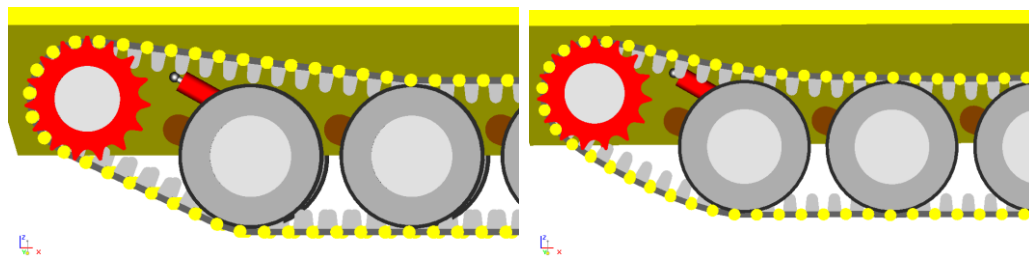

Figure 1.181. Positions of track links before and after the equilibrium test

Initialization of test parameters

There are no parameters in this test.

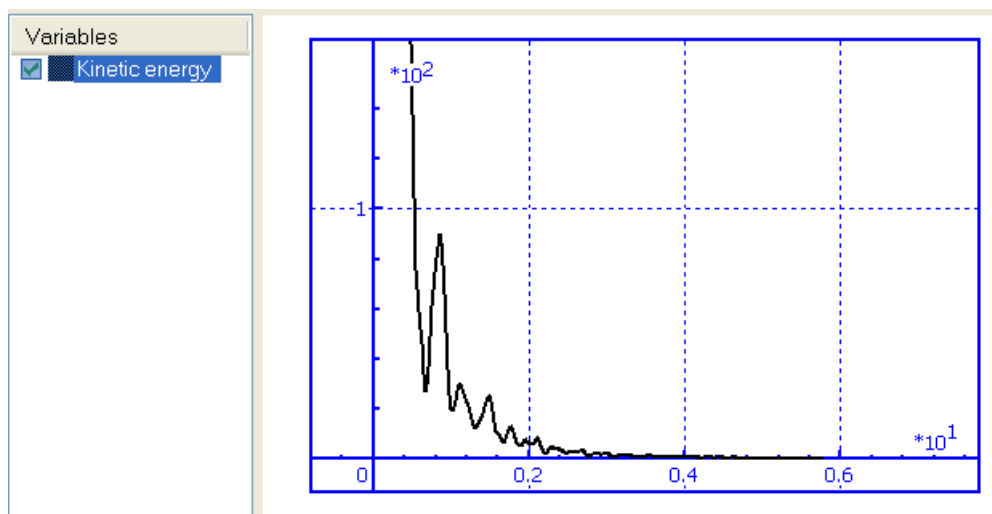

Figure 1.182. Decrease of kinetic energy of TV

Test variables.

Kinetic energy is the standard variable of the test. User stops the test when the energy value becomes small enough, Figure 1.182.

Plots of road wheel loads are useful during the test as well, Figure 1.183. These variables are available in the **Wizard of variables**, Sect. 1.2.6. *"List of special variables for tracked vehicles"*, p. 1-171.

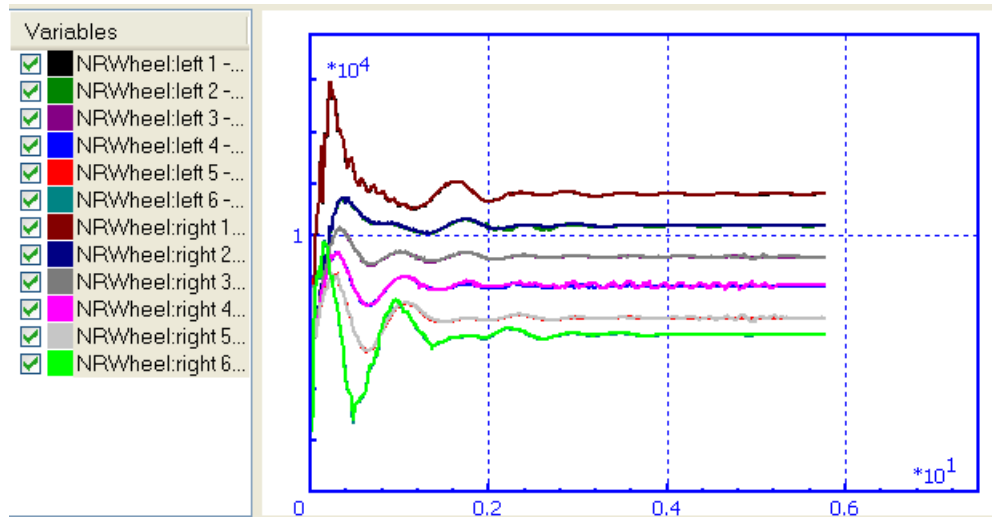

Figure 1.183. Road wheel loads

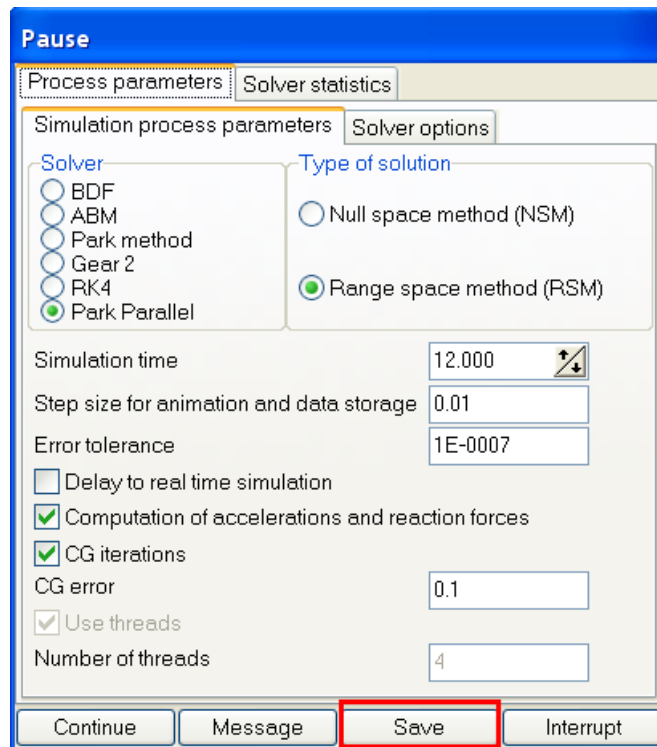





Figure 1.184. Saving body positions

Test results.

To save the test results it is necessary

- to call the pause mode by the  button in the **Process parameters** window or by the ESC key;
- to save body positions in a *.xv file by the **Save** button, Figure 1.184;
- to break the simulation by the **Interrupt** button;
- in the Object simulation inspector
 - open the Initial conditions tab;
 - read the just saved file by the  button;
 - set zero values for velocities by the  button;
 - save the final values of coordinates in a file by the  button.

The created file is used in some other tests for setting initial positions of bodies.

Remark. The Track tension or Tension by joint preload tests can be used instead of the Equilibrium test.

1.2.4.5.2. Test: track tension

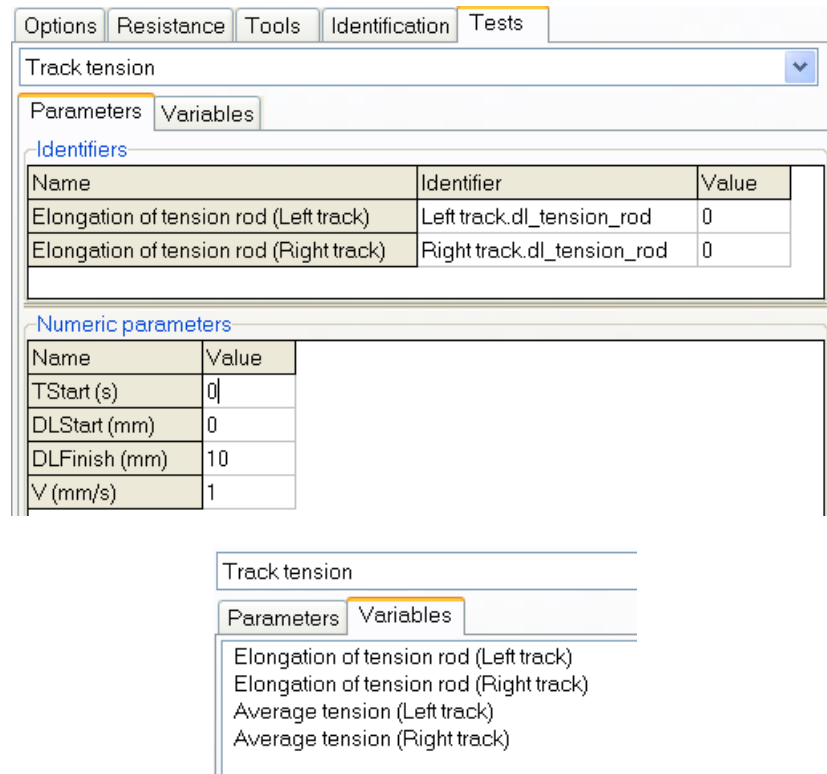

Figure 1.185. Parameters and variables of the test Track tension

Test objective.

This is an auxiliary test, which is used for setting a desired track tension in case of track links with *rigid joints*. Change in the track tension is achieved by increase of length of a tension force element, Sect. 1.1.1.4.2. "Idler and tension device", p. 1-31.

Remark. Ground friction is automatically set to zero during this test.

Initialization of test parameters.

Identifiers: identifiers parameterizing elongation of the tension force element for the left and right tracks is to be assigned. The default identifier is *dl_tension_rod*. If the user renamed the identifier in the idler template, he must select the corresponding identifiers from the list after the double click on the corresponding table cell (Figure 1.185, the second column in the table).

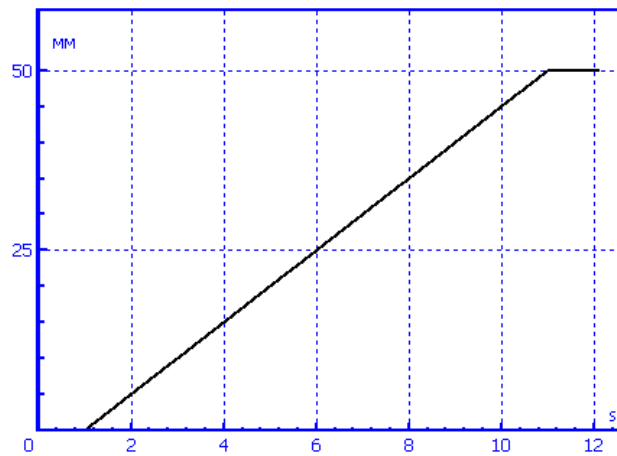

Figure 1.186. Example of dependence of elongation on time

Numeric parameters set the process of the tension rod elongation:

TStart (s): moment of elongation start;

DLStart (mm): initial value of elongation;

DLFinish (mm): final value of elongation;

V (mm/s): elongation velocity.

An example of the elongation process is shown in Figure 1.186 for the following parameter values:

TStart=1; DLStart=0; DLFinish=50; V=5.

Test variables.

The list of standard test variables includes the value of elongation as well as an average track tensions S , Figure 1.185

$$S = \frac{\sum_{i=1}^n S_i}{n},$$

where S_i is the reaction force in track joint i , n is the number of links.

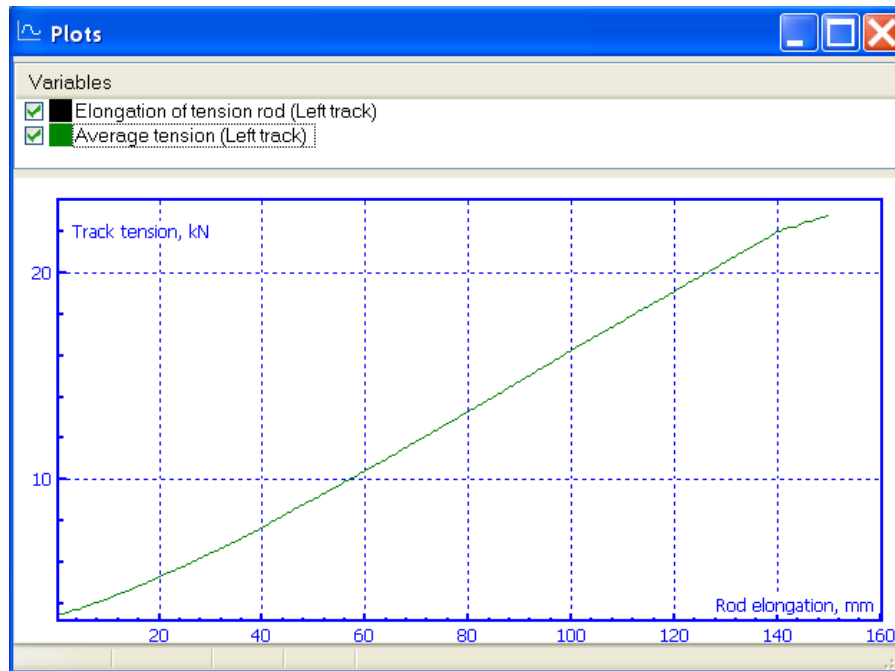

Figure 1.187. Tension vs. elongation

Test results.

The main result of the test is the plot of tension force vs. elongation, Figure 1.187. To get this plot, the following steps are necessary before start of the simulation:

- open new graphic window;
- drag two variables from the table in Figure 1.185 by the mouse into the window: elongation and tension;

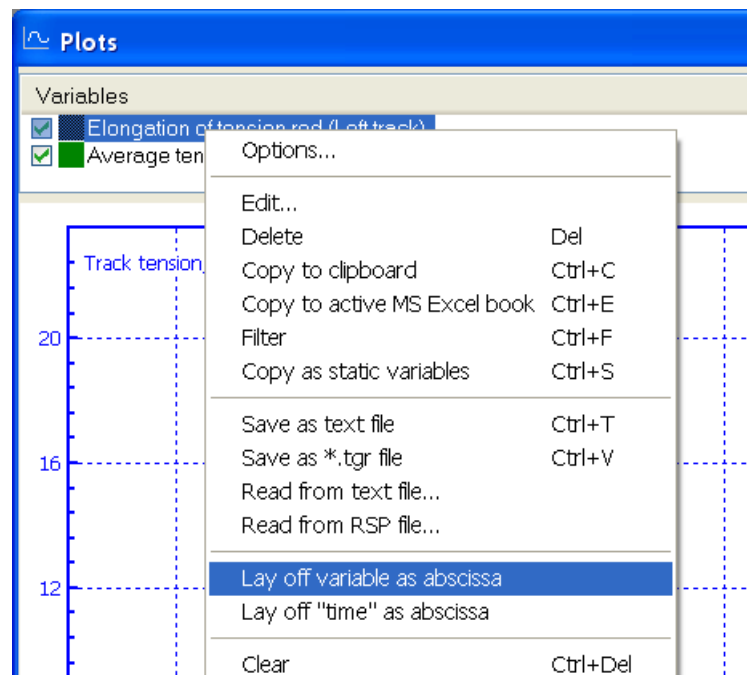

Figure 1.188. Elongation must be laid off as abscissa

- lay off the elongation as abscissa: select the variable in the list of graphic window, call the context menu by the right mouse button and select the menu command, Figure 1.188.

After the simulation,

- evaluate the elongation l^* by the necessary tension, Figure 1.187;
- replace the maximal elongation in the table of numeric test parameters DLFinish by the value l^* (Figure 1.185) and run simulation again;
- following the Sect.
-

- Test: Equilibrium, save coordinates in a file and use these values as initial conditions for other tests;
- finally, set the elongation l^* as the standard one in the box **Elongation of tension rod**, the **Tracked vehicle | Options | General** tab, Sect. 1.2.4.1.1. "*General options*", p. 1-128, Figure 1.158.

Remark. The test must be repeated every time when the tension value is changed or if parameter values exerting the tension like suspension stiffness are changed.

1.2.4.5.3. Test: tension by preload

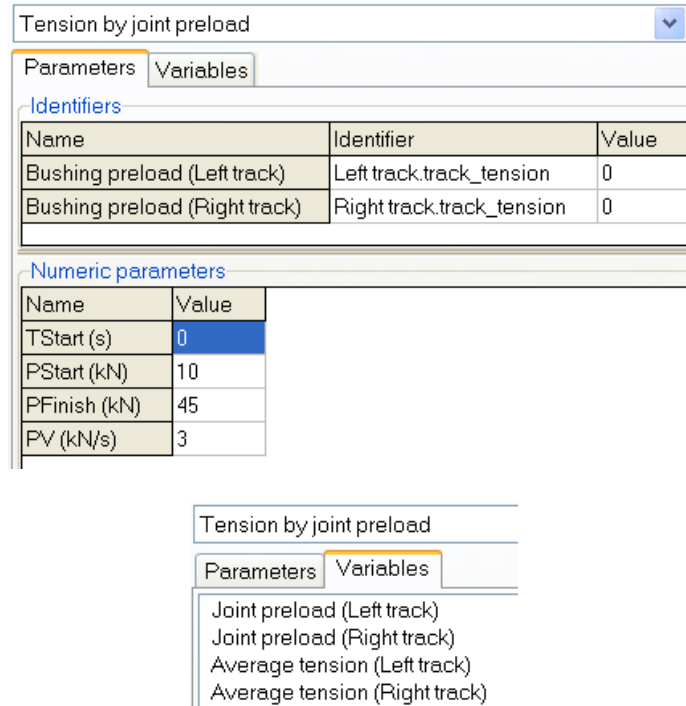

Figure 1.189. Parameters and variables of the test

Test objective.

This is an auxiliary test, which is used for setting a desired track tension in case of track links with *flexible and parallel joints*. The desired track tension is achieved by change of preload force in joint, Sect. 1.1.1.4.2. "*Idler and tension device*", p. 1-31.

Remark. Ground friction is automatically set to zero during this test.

Initialization of test parameters.

Identifiers: identifiers parameterizing the preload force in track link joints for the left and right tracks is to be assigned. The default identifier is *track_tension*. If the user renamed the identifier in the idler template, he must select the corresponding identifiers from the list after the double click on the corresponding table cell (Figure 1.189, the second column in the table).

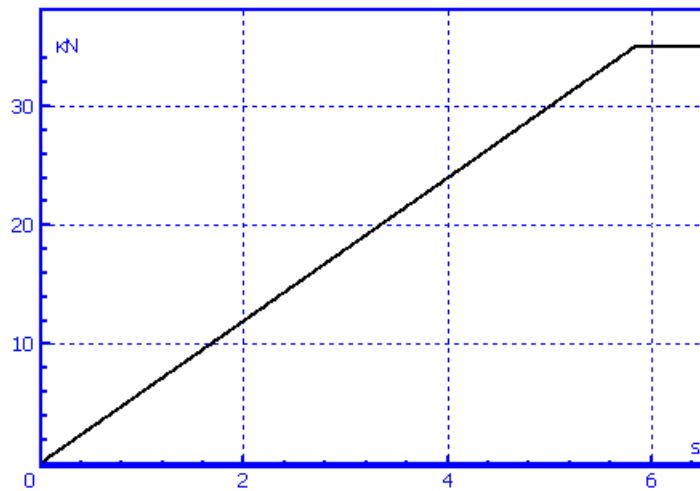

Figure 1.190. Example: preload vs. time

Numeric parameters set the process of increase the preload value:

TStart (s): moment of preload increase start;

PStart (kN): initial value of preload;

PFinish (kN): final value of preload;

PV (kN/s): preload rate.

An example of dependence of the preload on time is shown in Figure 1.190 for the parameter values:

$$TStart=0; PStart=0; PFinish=35; V=6.$$

Test variables.

The list of standard test variables includes the value of preload as well as an average track tensions S , Figure 1.185

$$S = \frac{\sum_{i=1}^n S_i}{n},$$

where S_i is the force in track joint i , n is the number of joints.

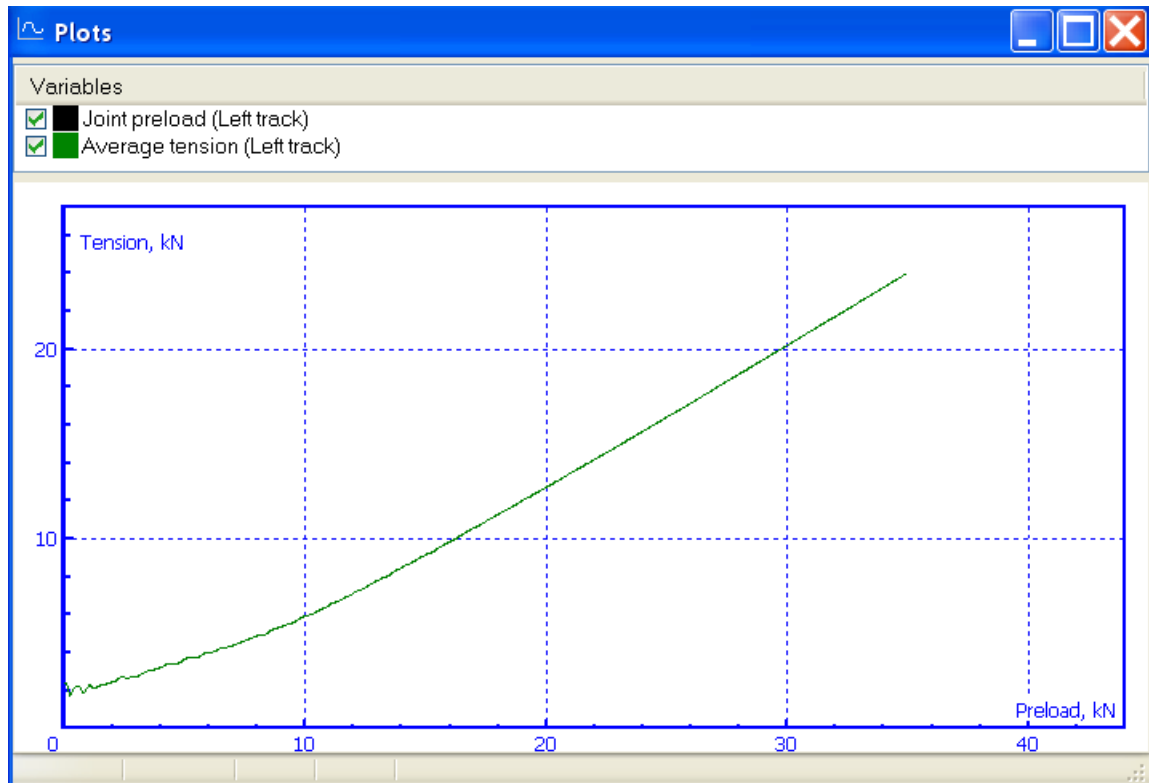

Figure 1.191. Example: tension vs. preload

Test results.

The main result of the test is the plot of tension force vs. preload, Figure 1.191. To get this plot, the following steps are necessary before start of the simulation:

- open new graphic window;
- drag two variables from the table in Figure 1.189 by the mouse into the window: preload and tension;

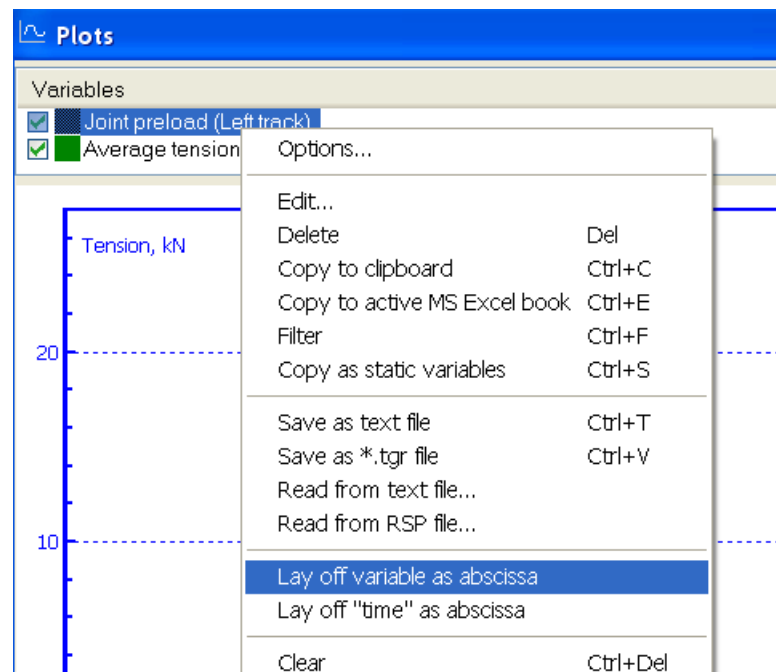

Figure 1.192. Preload must be laid off as abscissa

- lay off the preload as abscissa: select the variable in the list of graphic window, call the context menu by the right mouse button and select the menu command, Figure 1.192.

After the simulation,

- evaluate the preload P^* by the necessary tension, Figure 1.191;
- replace the maximal preload in the table of numeric test parameters PFinish by the value P^* (Figure 1.185) and run simulation again;
- following the Sect.

- *Test:* Equilibrium, save coordinates in a file and use these values as initial conditions for other tests;
- finally, set the preload value P^* as the standard one in the box **Preload in joint**, the **Tracked vehicle | Options | General** tab, Sect. 1.2.4.1.1. "*General options*", p. 1-128, Figure 1.158.

Remark. The test must be repeated every time when the tension value is changed or if parameter values exerting the tension like suspension stiffness are changed.

1.2.4.5.4. Test: Vertical harmonic loading

Test objectives.

This is an auxiliary test for evaluation of stiffness characteristics of the suspension system as a plot of force vs. vertical movement. During the test, a harmonic force F is applied to the center of gravity of the TV hull

$$F = F_0(1 - \cos(2\pi ft))/2,$$

where F_0 is the maximal force value, f is the excitation frequency in Hz. The force is directed downwards.

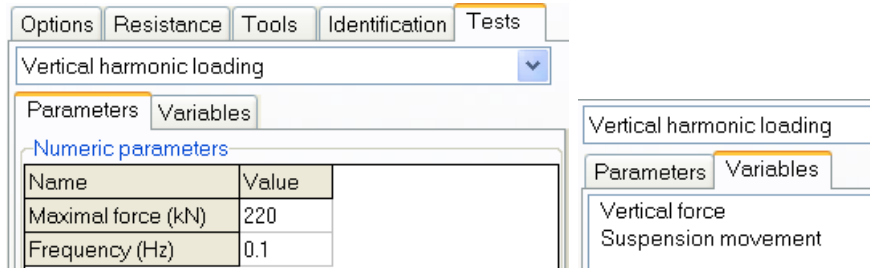

Figure 1.193. Parameters and variables of the test

Initialization of test parameters.

The user sets two numeric parameters: the maximal force F_0 and the frequency f , Figure 1.193.

Test variables.

The list of standard variables includes the excitation force value (kN) and the vertical displacement of the hull center of gravity (mm).

Test results.

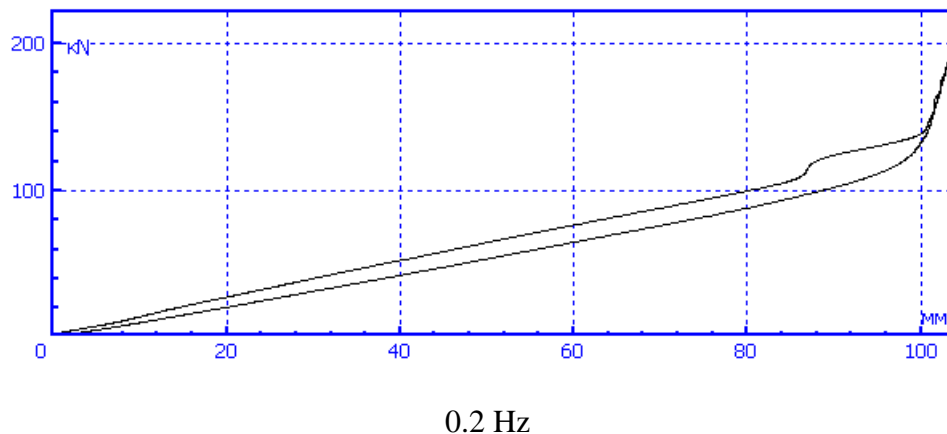

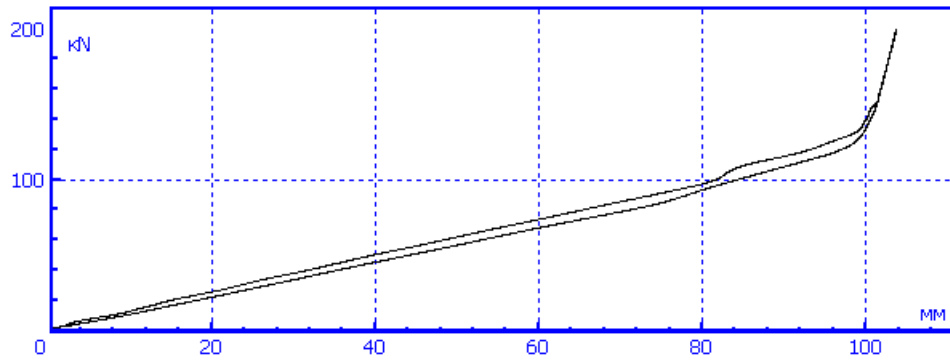

0.1 Hz

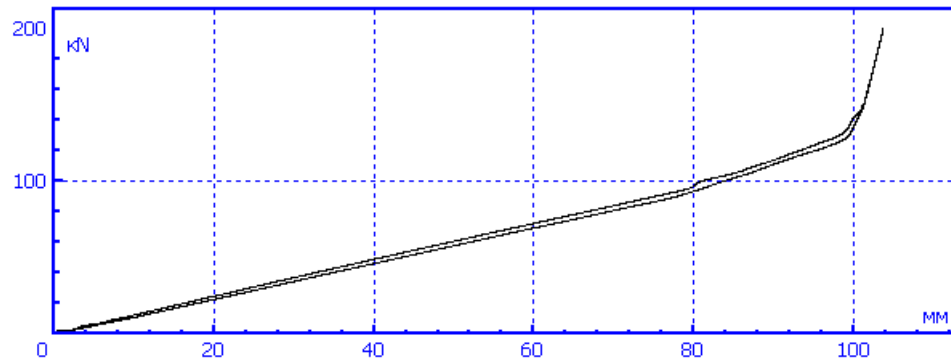

0.05 Hz

Figure 1.194. Force versus displacement for different values of frequency

The main result is the plot of force versus displacement, Figure 1.194.

The following steps are required for getting the plot:

- open a new graphic window;
- drag both variable in the window from the list in Figure 1.193;
- lay off the hull movement as abscissa.

1.2.4.5.5. Test: Computation of initial velocities

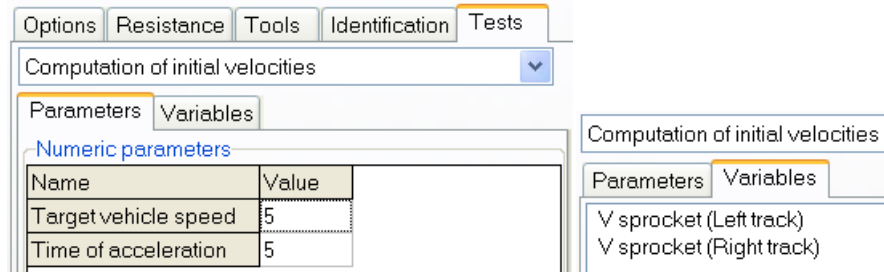

Figure 1.195. Parameters and variables of the test

Test objectives.

This is an auxiliary test for creation of a file of initial conditions, which is used for computation of initial velocities of bodies in the case of an arbitrary initial speed of TV.

The test runs as follows. At start of the test the TV does not move. Then the ground is moved backwards with a constant acceleration, and the hull is locked in the horizontal plane. As a result, the tracks move with acceleration. After reaching a definite speed, the ground moves uniformly. After finish the test, the user saves positions and velocities of bodies in a file [numeric value of speed*10].tvv, e.g., 50.tvv corresponds to the test results with the target speed 5 m/s.

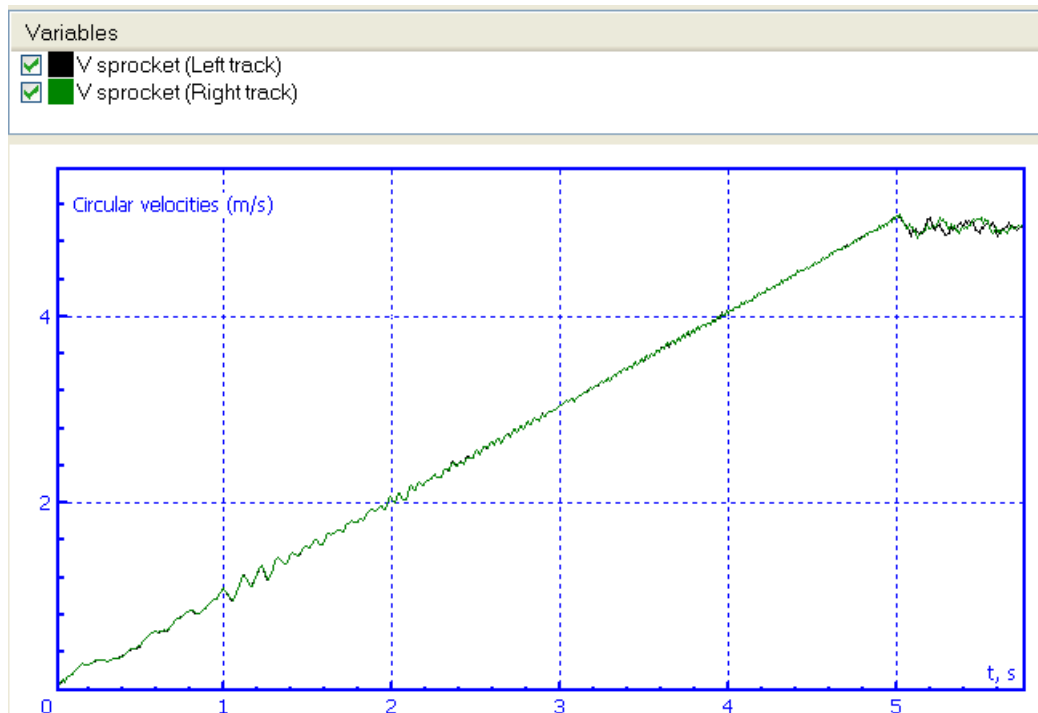

Figure 1.196. Example: circular velocities vs. time

The created file is used by the main tests, where the user can set any initial speed of TV. By the start of such a test, UM finds the *.tvv file with the nearest value of speed and computes velocities of all the bodies using the saved data. Usually it is enough to create only one *.tvv file with an average speed, and UM correctly specifies velocities of bodies for any initial speed of TV.

Initialization of test parameters.

The list of test parameters includes two numeric constants: the target speed of TV and the time interval for the uniform acceleration.

Test variables.

Two standard variables are the circular velocities of sprockets

$$v = \omega R_s,$$

where ω, R_s are the angular velocity of a sprocket and the sprocket radius on the pin centers. An example is shown in Figure 1.196.

1.2.4.5.6. Tests with longitudinal motion of TV

There are three tests with longitudinal motion of TV:

- straight motion,
- open loop steering,
- test with driver.

Consider common parameters of these tests.

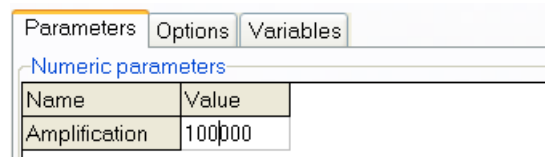

Name	Value
Amplification	100000

Figure 1.197. Value of amplification

1. **Amplification** k (Figure 1.197) in the control of the circular speed of sprockets, Sect. 1.2.2.1. "*General information about controlled motion of TV*", p. 1-121.

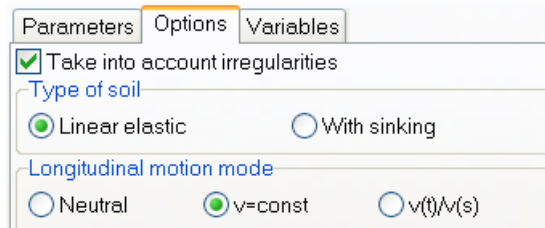

Figure 1.198. Test options

2. Option **Take into account irregularities** (Figure 1.198), Sect. 1.2.4.1.2. "*Irregularities*", p. 1-129.
3. **Type of soil** allows setting either linear model of the ground (Sect. 1.2.1.2.1. "*Ground model without sinkage*", p. 1-113), or a model with sinkage, Sect. 1.2.1.2.2. "*Bekker ground model*", p. 1-113. In the first case, the ground stiffness, damping ratio and coefficient of friction are specified in the table of contact parameters, Sect. 1.2.4.4.1. "*Track contact parameters*", p. 1-142. In the second case the parameters are set in the table of terrain parameters, Sect. 1.2.4.4.4. "*Terrain parameters*", p. 1-145.
4. **Longitudinal motion mode** includes three modes of the TV speed control:
 - Neutral: speed control is not used;
 - $v=\text{const}$: motion with a constant speed;
 - $v(t)/v(s)$: dependence of speed on time or distance is supported.

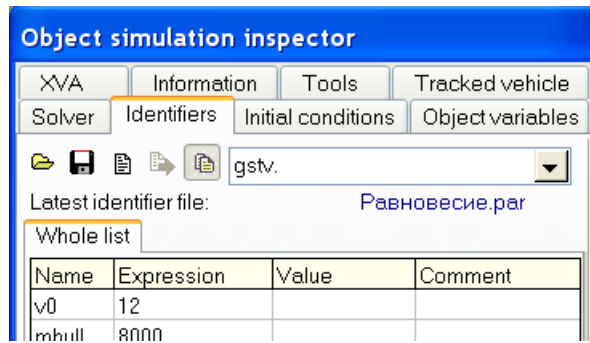

Figure 1.199. Assignment of speed for the neutral and $v=\text{const}$ modes

In the case of two first modes, the initial speed is assigned to the identifier **v0** on the **Identifiers** tab of the inspector, Figure 1.199.

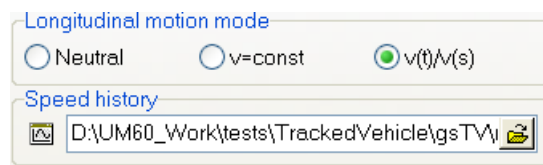



Figure 1.200. File with speed history

In the third case the speed vs. time\distance history must be assigned, Sect. 1.2.4.3. *"Tools tab: setting speed history"*, p. 1-140. The file is assigned by the  button in Figure 1.200.

1.2.4.5.6.1. Test: straight motion

Test objectives.

This is one of the main tests, which allows estimating dynamic performances of a TV. In the test, a straight motion of a TV is considered. Three modes of TV speed are implemented. Irregularities of the ground can be taken into account.

Test parameters are described in Sect. 1.2.4.5.6. "*Tests with longitudinal motion of TV*", p. 1-164.

The road irregularities are set on the **Options | Irregularities** tab, Sect. 1.2.4.1.2. "*Irregularities*", p. 1-129.

Test results.

All standard kinematic and dynamic variables can be considered as test results. Use the Wizard of variables for creating the variables, Sect. 1.2.6. "*List of special variables for tracked vehicles*", p. 1-171.

1.2.4.5.6.2. Test: open loop steering

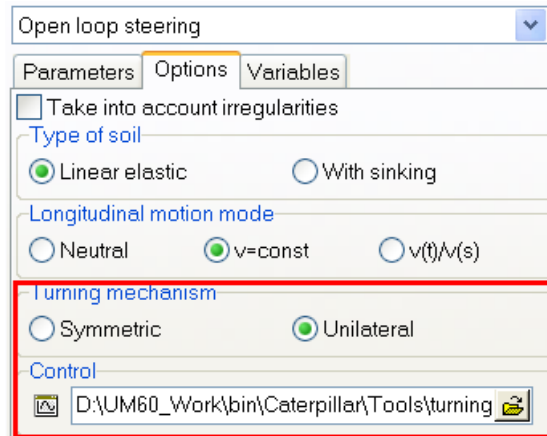

Figure 1.201. Parameters of open loop steering test

In addition to the standard parameters for tests with longitudinal motion, the test requires the following data:

- type of **turning mechanism**, Sect. 1.2.2.1. "General information about controlled motion of TV", p. 1-121.
- **control**: sprocket speed difference ΔV for turning the TV, Sect. 1.2.2.1. "General information about controlled motion of TV", p. 1-121, 0; the preliminary crated file is assigned by the button, Figure 1.201, Figure 1.202.

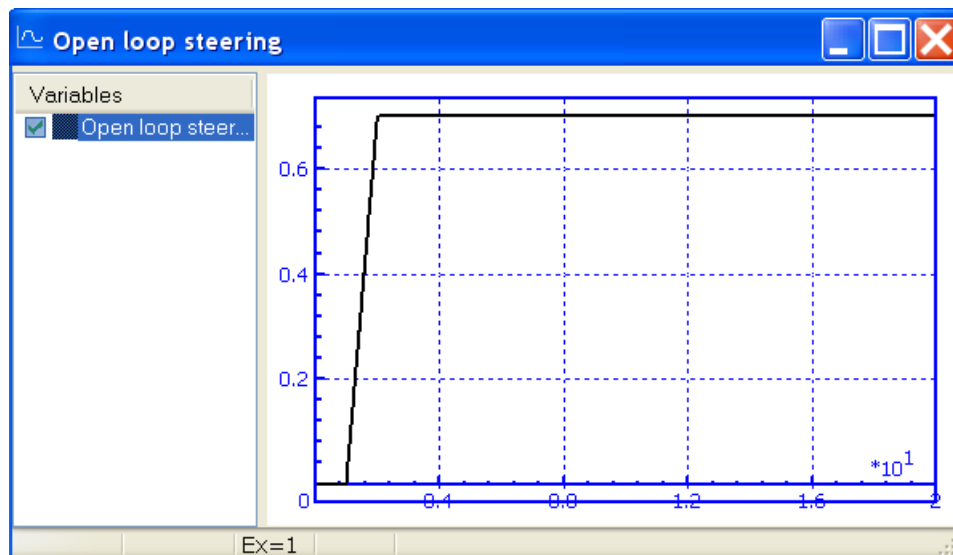

Figure 1.202. Speed difference ΔV versus time

1.2.4.5.6.3. Test with driver

In addition to the standard parameters for test with longitudinal motion of TV, Sect. 1.2.4.5.6. "Tests with longitudinal motion of TV", p. 1-164, the test requires the following data, Figure 1.203:

- type of **turning mechanism**, Sect. 1.2.2.1. "General information about controlled motion of TV", p. 1-121,
- **Macrogeometry type**
 - **2D curve**, Sect. 1.2.2.3.2. "Plane curve", p. 1-123, a file with a path curve must be assigned;
 - **3D testing area**, Sect. 1.2.2.3.3. "Testing area", p. 1-124, 1.2.4.1.3.1. "Routes on testing area", p. 1-133, a testing area must be loaded; if necessary, a list of routes is created (Sect. 1.2.4.1.3.1. "Routes on testing area", p. 1-133); after that a current route should be assigned from the drop-down list, Figure 1.203.

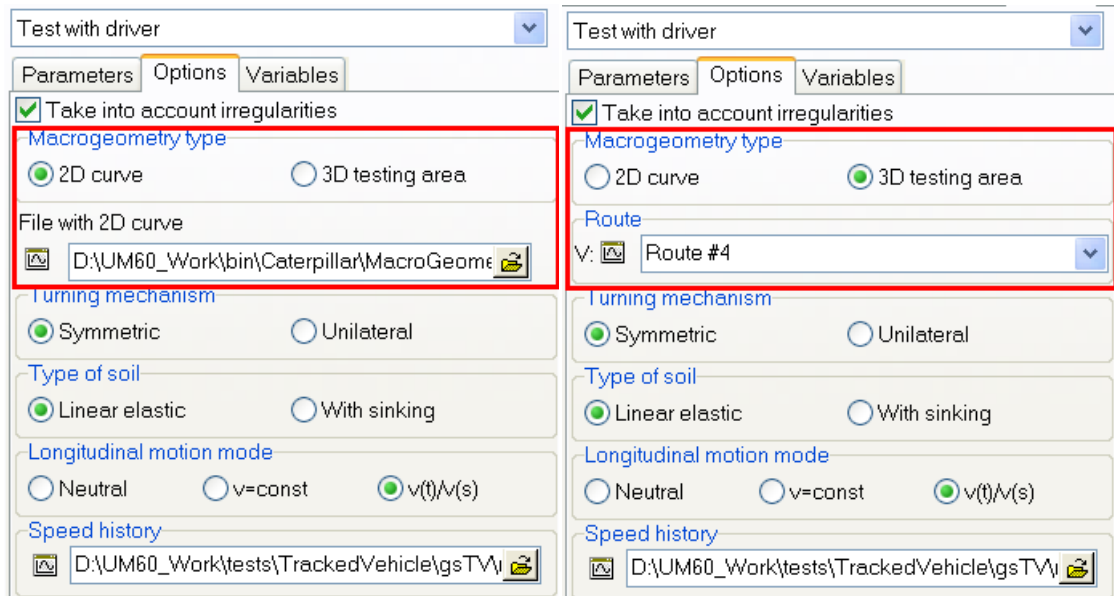

Figure 1.203. Parameters of test with driver

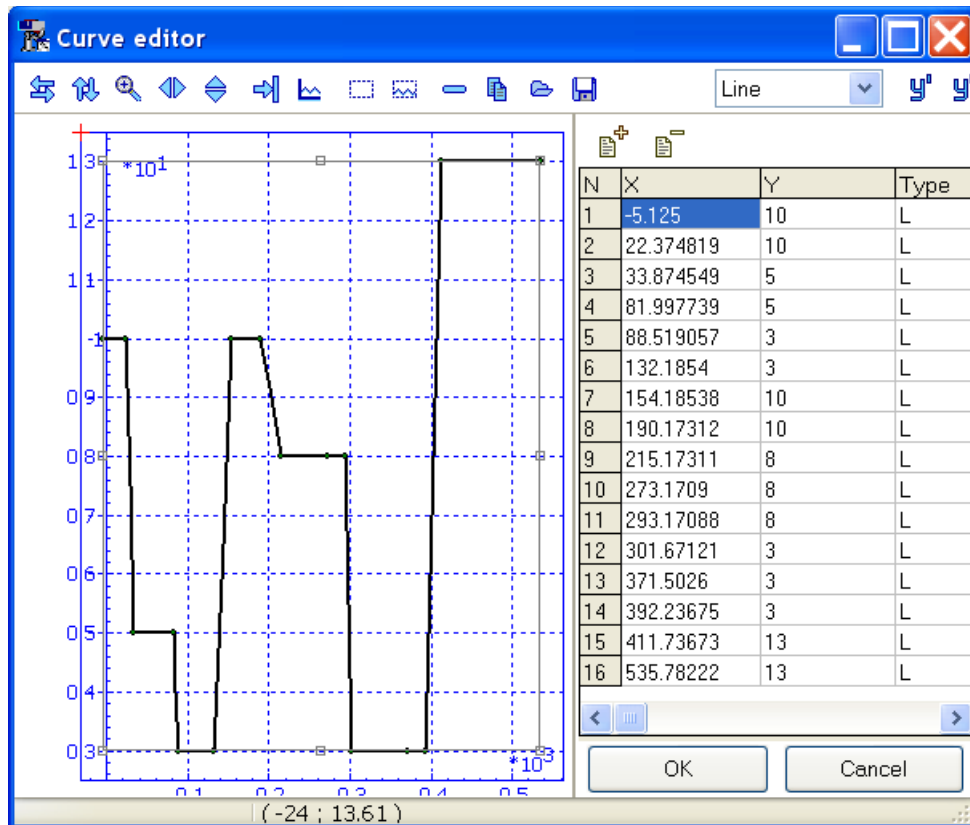
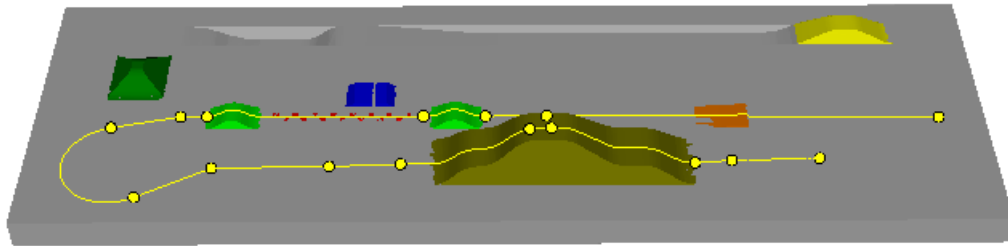



Figure 1.204. Setting speed along the route. Points on the plot correspond to the route markers

To set the plot of TV speed along the route, the button  is used. After the click on this button, the program opens the tab for setting speed history, Sect. 1.2.4.3. "Tools tab: setting speed history", p. 1-140. A plot template containing all the route markers is created automatically. All markers are shifted backwards on the TV length. The user should edit the plot in the curve editor, Figure 1.204, save data in a file and assign this file on the test parameter tab, the **Speed history** group, Figure 1.203.

1.2.5. Solver

The **Park parallel** solver is used for simulation of TV dynamics. This method is developed by authors of UM in 2009 specially for simulation of large models, in particular, with multi-core processors.

Parameters of the solver are set on the corresponding tab of the inspector. Typical parameter values are shown in Figure 1.205. The following remarks are important.

- The **Use threads** key can be used for **multi-core processors only**.
- The **Number of threads** parameter must not exceed the number of physical and logical cores on the local computer, which is specified automatically. It is recommended to test different values of this parameter to choose the optimal number of threads.
- The **CG error** parameter (parameter of accuracy of the conjugate gradient method) is selected by the user after a number of tests. The optimal value of this parameter corresponds to the fastest simulation.

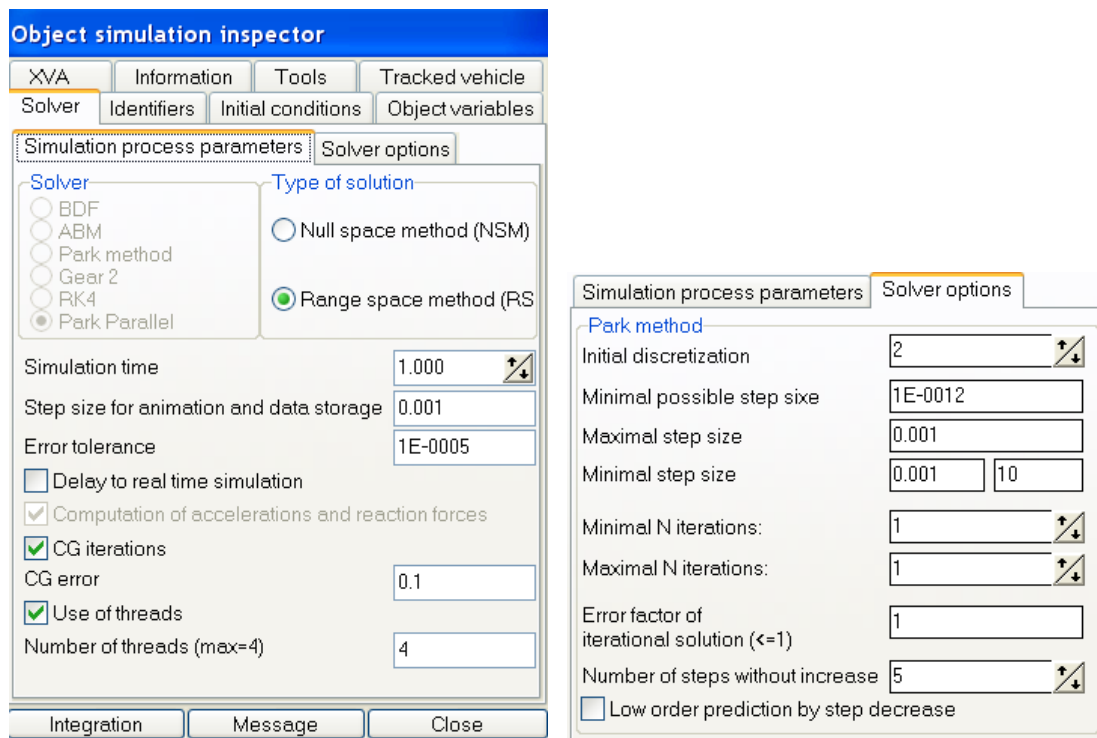

a

b

Figure 1.205. Recommended solver parameters

1.2.6. List of special variables for tracked vehicles

Analysis of TV dynamics is based on computation of dependences of some variables on time. Most of the variables are created with the **Wizard of variables**. To call the wizard, the **Tools | Wizard of variables...** menu command or the  button are used. Getting standard variables with the wizard is described in [Chapter 4](#), Sect. *Wizard of variables, List of variables*.

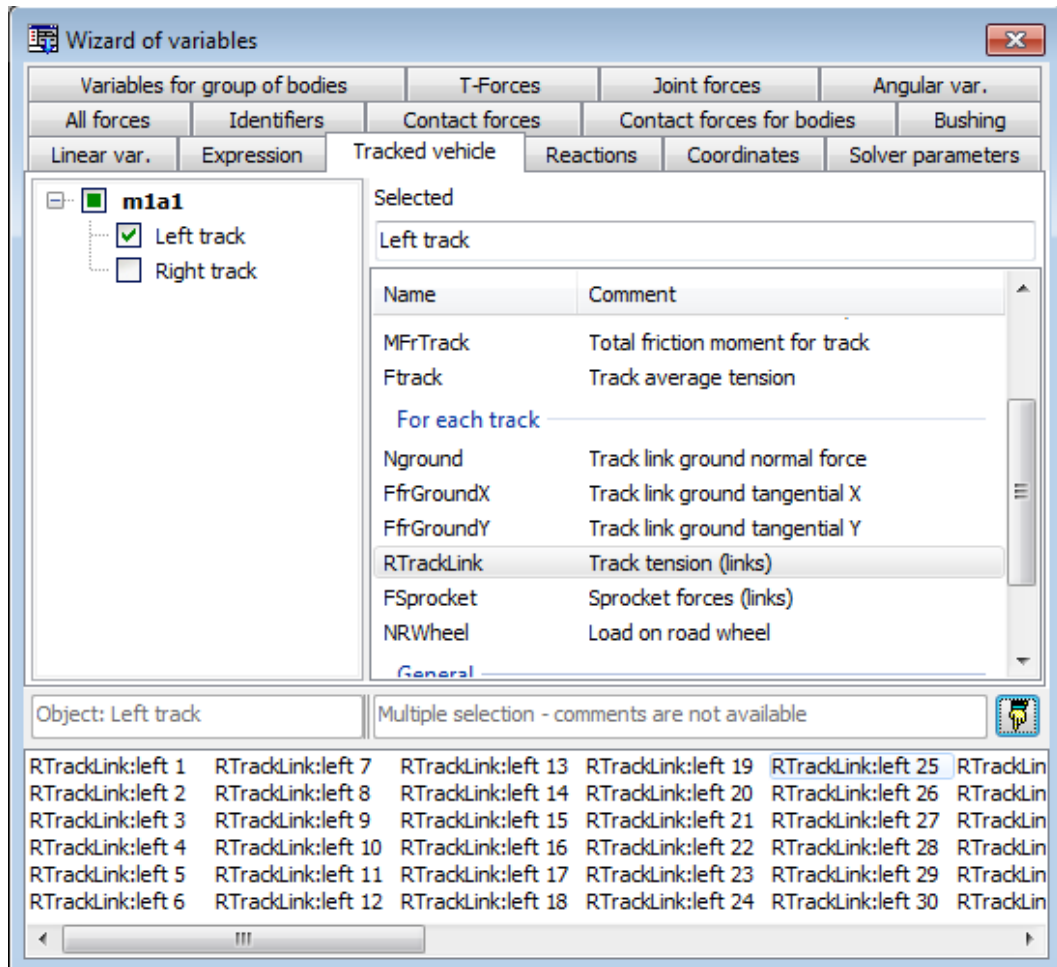

Figure 1.206. List of special TV variables

Here we consider variables related to the dynamics of TV only, the **Tracked vehicle** tab of the wizard, Figure 1.206, Table 1.23.

Table 1.23

Name of variable	Comments
VSprocket	(m/s) Circular velocity of sprocket $v = \omega R_s$, where ωR_s are the angular velocity of the sprocket and the radius on pin centers.
MSprocket	(Nm) Drive torque by control of TV speed.
FTrack	(N) Mean track tension, $S = \sum_{i=1}^n S_i/n$ where S_i is the force in the joint for track link i , n is the number of links.

NGround	(N) Normal force applied to a link from the ground. Number of variables is equal to the number of links.
FFrGroundX	(N) Friction force applied to a link from the ground in longitudinal direction. Number of variables is equal to the number of links.
FFrGroundY	(N) Friction force applied to a link from the ground in lateral direction. Number of variables is equal to the number of links.
RTrackLink	(N) Longitudinal force in a link joint Si. Number of variables is equal to the number of links.
FSprocket	(N) Magnitude of a pin\sprocket force. Number of variables is equal to the number of links.
NRWheel	(N) Road wheel loads. Number of variables is equal to the number of road wheels.
Distance	(M) Distance from the motion start. The variable is used in the main tests.

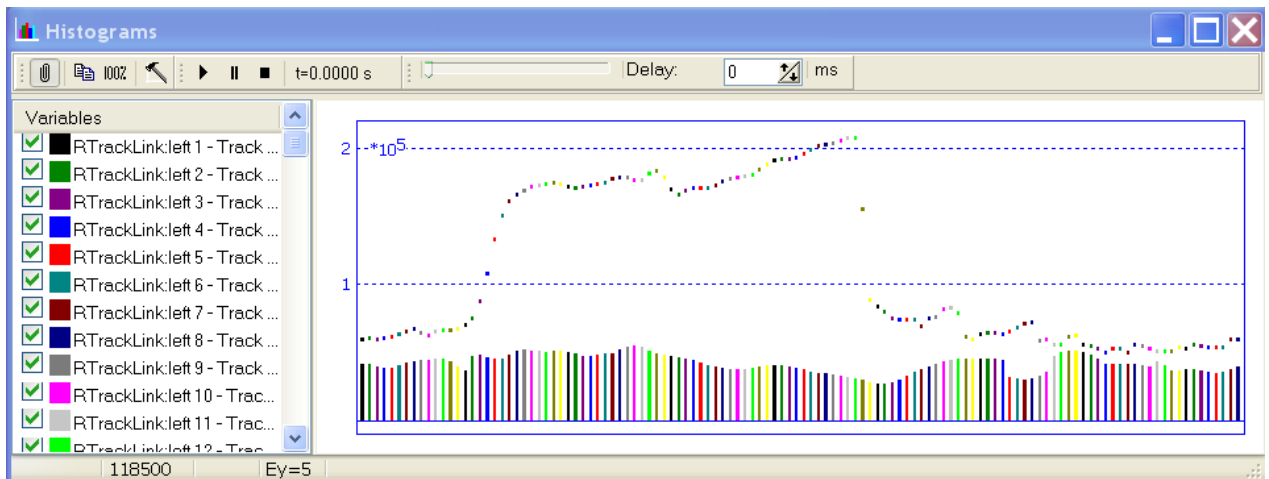

Figure 1.207. Histogram window

Remark. A histogram window is useful for analysis of large number of variables, Figure 1.207.

1.2.7. Features of multivariant calculations with TV

Consider some features of analysis of a TV dynamics with *UM Experiments* module.

1.2.7.1. Use of standard internal identifiers

Standard internal identifiers are introduced for some parameters specified by the user to increase the efficiency of the UM Experiments module in analysis of TV. These identifiers are used for variation of the corresponding parameters in the set of numeric experiments.

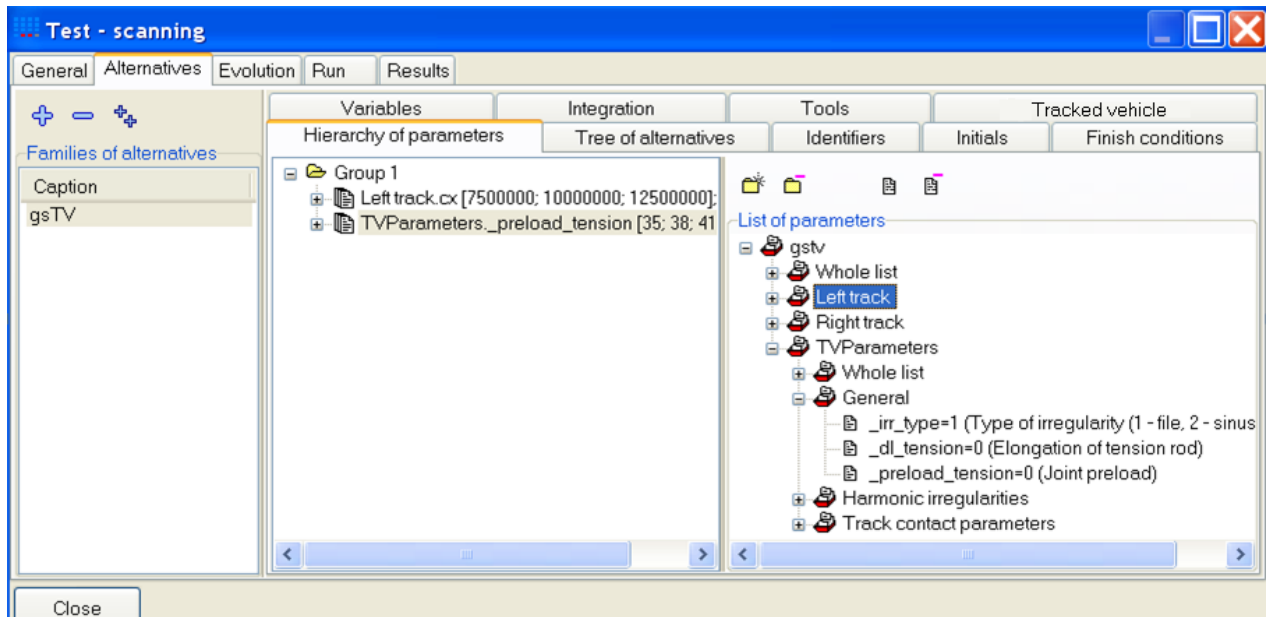

Figure 1.208. Use of standard internal identifiers

The list of standard internal identifiers is available in the parameter tree on the tab **Alternatives | Hierarchy of parameters | List of parameters**, branch **TVParameters**, Figure 1.208.

The standard internal identifier *_preload_tension* is used in the example in Figure 1.208 for planning of three computations with different stiffness constant in a flexible joint parameterized in the TV model by the usual identifier *cx*. The standard internal identifier is used for simultaneous modification of the bushing preload, which set the desired track tension for different values of bushing stiffness.

Test: tension by preload, as well as Figure 1.158). Three numeric experiments will be run according to the plan:

- variant 1: $c_x=67\,700\,000$ N/m, $_preload_tension=35$ kN,
- variant 2: $c_x=90\,252\,000$ N/m, $_preload_tension=38$ kN,
- variant 3: $c_x=112\,800\,000$ N/m, $_preload_tension=41.5$ kN.

The full list of standard internal identifiers is available in Table 1.24.

Table 1.24

List of standard internal identifiers

Branch of the parameter tree	Name of identifier	Comments
General	$_irr_type$	Type of irregularities: 1 – file, 2 – sinusoidal, Sect. 1.2.4.1.2. <i>"Irregularities"</i> , p. 1-129, Figure 1.159
	$_dl_tension$	(mm) Elongation of tension rod, Sect. 1.2.4.1.1. <i>"General options"</i> , p. 1-128, Figure 1.158
	$_preload_tension$	(kN) Joint (bushing) preload, Sect. 1.2.4.1.1. <i>"General options"</i> , p. 1-128, Figure 1.158
Harmonic irregularities Sect. 1.2.4.1.2.2. <i>"Harmonic irregularities"</i> , p. 1-130, Figure 1.159.	$_a$	(m) Amplitude
	$_l$	(m) Wave length
	$_x0$	(m) Phase shift of left wave
Track contact parameters Sect. 1.2.4.4.1. <i>"Track contact parameters"</i> , p. 1-142.	$_c_ground$	Ground stiffness (N/m)
	$_beta_ground$	Ground damping ratio
	$_ffr_ground$	Coefficient of ground friction
	$_c_sprocket$	Sprocket stiffness (N/m)
	$_beta_sprocket$	Sprocket damping ratio
	$_ffr_sprocket$	Coefficient of sprocket frict.
	$_c_roadwheel$	Road wheel stiffness (N/m)
	$_beta_roadwheel$	Road wheel damping ratio
	$_ffr_wheel$	Coefficient of wheel friction
	$_c_idler$	Idler stiffness (N/m)
	$_beta_idler$	Idler damping ratio
	$_c_roller$	Roller stiffness (N/m)
	$_beta_roller$	Roller damping ratio
	$_c_lateral$	Lateral stiffness (N/m)
$_beta_lateral$	Lateral damping ratio	
$_h_guidetooth$	Guide tooth height (mm)	

Let us consider an example of a multivariant experiment in which a TV moves on different sinusoidal irregularities with different speed values, Figure 1.209.

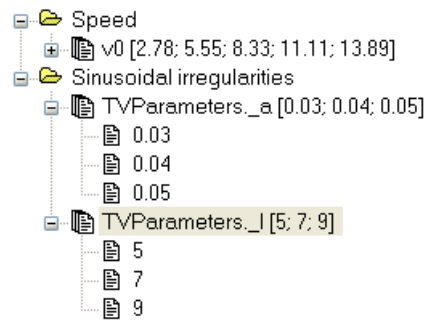

Figure 1.209. Plan of multivariant calculations

In this example, the plan includes 15 computations for five speeds (10, 20, 30, 40, 50 km/h). Three computations with different sinusoidal irregularities are planned for each of the speed values:

- variant 1: amplitude 3 cm, length 5 m;
- variant 2: amplitude 4 cm, length 7 m;
- variant 3: amplitude 5 cm, length 9 m.

1.2.7.2. Finish conditions of experiments by distance

It is useful to set the finish conditions by distance from the start for computation of motion with different speeds. As a result, the distance will be the same for all the experiments. The following steps are to be made to assign the corresponding finish condition.

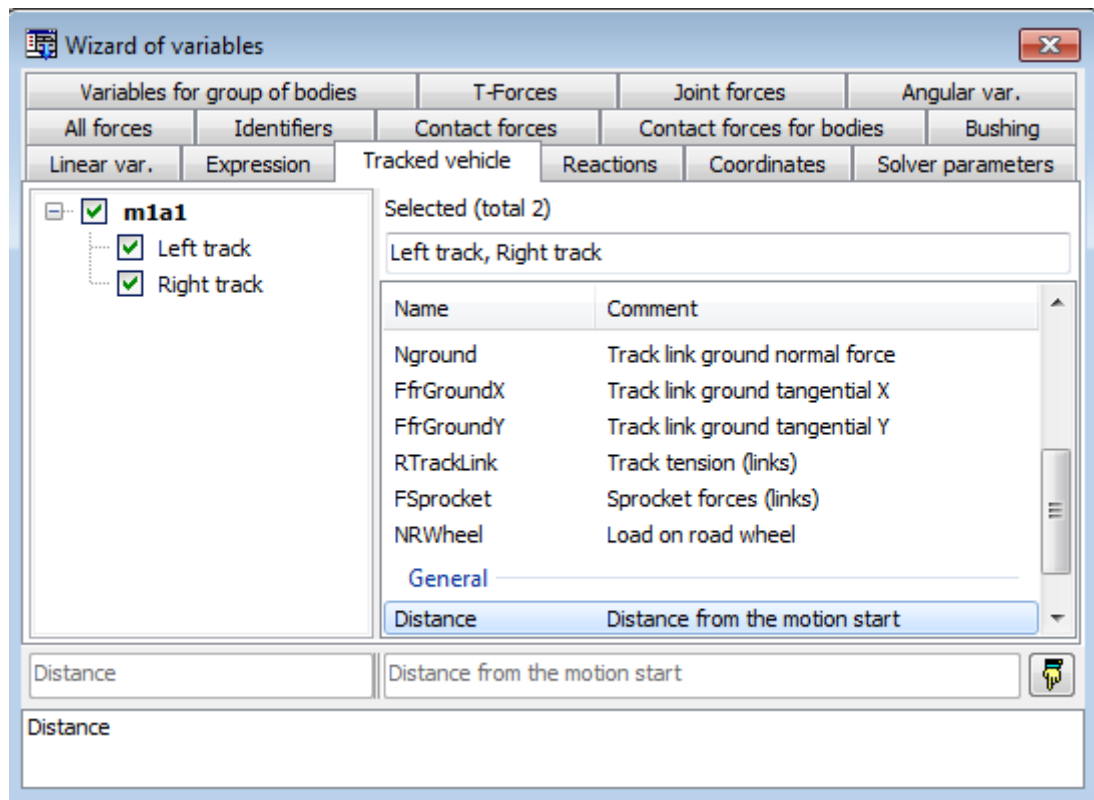

Figure 1.210. Distance as a variable

- Create the distance variable, Figure 1.210.

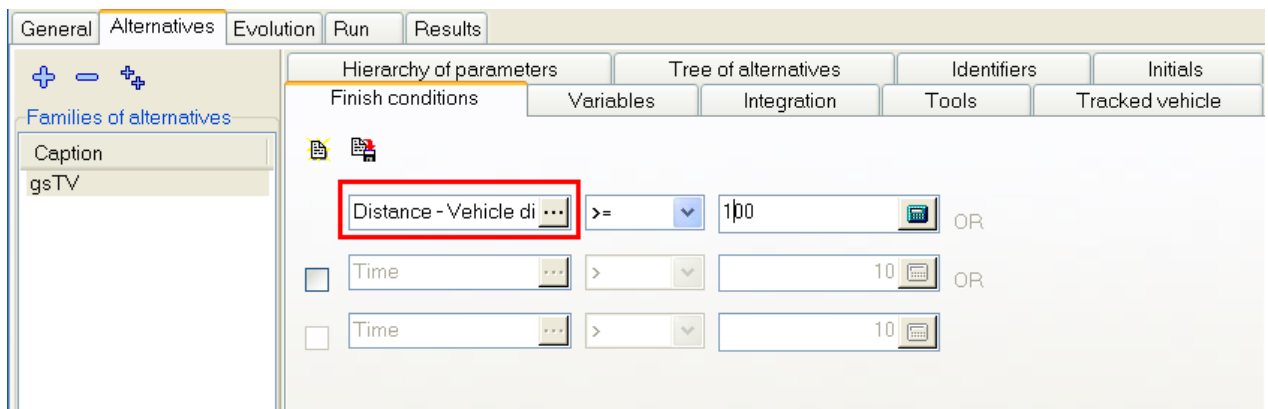

Figure 1.211. Finish conditions

- Drag the variable into the box on the **Alternatives | Finish conditions** tab, Figure 1.211.
- Set the distance value (100 m in Figure 1.211).

1.3. References

- [1] Wong J. Theory of ground vehicles, 3rd ed. John Wiley & Sons, 2001.
- [2] Edwards P., Differentials, the Theory and Practice. 3. Tank steering systems. Constructor Quarterly, No. 1, Sept 1988.
- [3] Johns W.E., Tracked Vehicle Steering. <http://www.gizmology.net/tracked.htm>.
- [4] Гусеничные транспортеры-тягачи / Под ред. В.Ф. Платонова. М.: Машиностроение. 1972.
- [5] Bekker M.G. Introduction to Terrain-Vehicle Systems. Univ. of Michigan Press. 1969.