



User`s manual



Simulation of Rail Vehicles and Bridges Interactions

The model of a rail vehicle and a bridge interaction taking into account flexibility of the bridge are considered. Issues of preparing model of flexible bridges and simulation of vehicle-bridge interaction are discussed

Contents

21. SIMULATION OF VEHICLE-BRIDGE INTERACTION	1-3
21.1. INTRODUCTION.....	1-3
21.2. MATHEMATICAL MODEL OF INTERACTION	1-3
21.3. MOVING LOAD	1-6
21.4. PREPARING THE MODEL OF FLEXIBLE BRIDGE.....	1-8
21.5. SIMULATION OF VEHICLE-BRIDGE INTERACTION	1-14
21.6. SAMPLE MODEL	1-18

1. Simulation of Vehicle-Bridge Interaction

1.1. Introduction

The module is aimed to build and analyze models that take into account the mutual influence of the dynamics of moving railway vehicles and flexible bridges. **UM VBI** module requires the following modules: **UM Loco** to simulate railway vehicle dynamics and **UM FEM** to simulate dynamics of flexible bridges.

The technique of modeling the dynamics of railway vehicles is described in [Chapter 4](#) of UM User's Manual. When moving on a flexible bridge all the variables related to the railway vehicle are calculated taking into account the influence of the dynamics of the bridge.

The bridge is considered as the flexible subsystem. A modal approach is used to simulate the dynamics of flexible bodies. An algorithm for creating a subsystem imported from finite element analysis (FEA) software ANSYS and MSC.NASTRAN, as well as tools to analyze its dynamics are described in [Chapter 11](#) of UM User's Manual. In this chapter a model of vehicle-bridge interaction is considered.

The main object of investigations can be both a bridge and a railway vehicle. As for a bridge the one of the purposes of researches could be the detection of resonance phenomena on railway bridges, dangerous operation conditions such as train speed and weight, specific bridge design and so on. As for high speed trains the dynamic analysis is necessary because of resonance phenomena of the structures due to regularly spaced axle groups of the train. In case of resonance excessive bridge deck vibration can cause loss of wheel/rail contact, destabilization of the ballast and exceeding the stress limits.

Analysis of dynamics of the railway bridge and time histories of stresses and strains are required for the calculation of their durability. In this case, stress loading blocks are results of dynamic simulation. These blocks are calculated based on time histories of bridge stresses obtained for selected mode of loading. The loading depends on weight and speed of rail vehicles, track irregularities on the bridge and so on.

As for railway vehicle dynamics it is important to consider additional flexibility of the bridge in both vertical and lateral dynamics on safety, stability and ride comfort.

Usually, research of dynamics of railway bridges is carried out based on simplified description of the vehicle-bridge interaction. The widespread approach supposes analysis of a finite element model of a bridge under action of the moving loading which simulates a train. In most cases, constant values of forces which correspond to weight distribution of the train vehicles are considered. Thus, dynamics of the vehicles is not taking into account within the simplified approach. Besides, such models do not take into account mutual influence between vehicles and bridges. It is their main disadvantage.

1.2. Mathematical model of interaction

Universal Mechanism software considers a rail as a massless visco-elastic force element. Mathematical model of a rail and used assumptions are described in Sect. 1.2. *"Mathematical*

model of interaction", p. 1-3. Forces in the wheel-rail contact depend on the current position and velocity of the points on a rail under the wheel (in the contact patch).

Lateral and vertical forces between the rail and the foundation are calculated according to the following formula (Figure 1.1):

$$R_y = -c_{ry}\Delta y_r - d_{ry}\Delta \dot{y}_r$$

$$R_z = -c_{rz}\Delta z_r - d_{rz}\Delta \dot{z}_r,$$

where R_y , R_z are lateral and vertical forces; c_{ry} , c_{rz} are lateral and vertical stiffness coefficients; d_{ry} , d_{rz} are lateral and vertical damping coefficients; Δy_r , Δz_r are lateral and vertical rail deflection. Stiffness and damping coefficients simulate mechanical properties of a superstructure of a bridge including ties, ballast layer, concrete slabs and rubber elements and so on.

Lateral and vertical rail deflections and their first derivatives (velocities) depend on the position and velocity of the attachment point K of the force element. Rotation of the rail is ignored. If the rail lies on the ground the point K does not move in lateral and vertical direction and its velocity is zero.

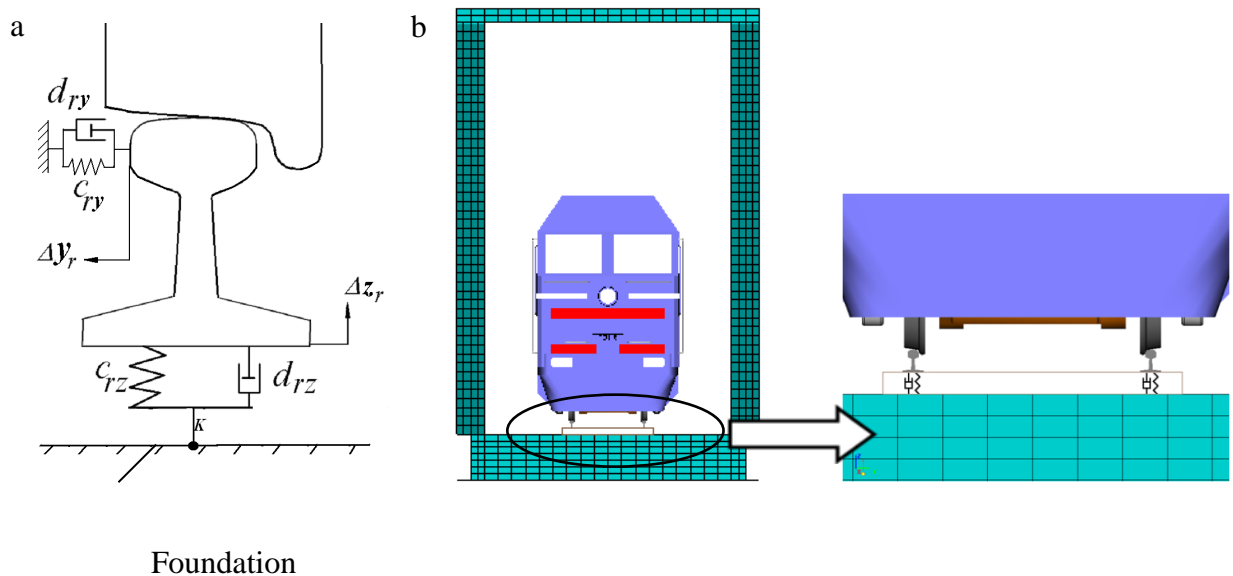

Figure 1.1. (a) rail as a massless force element; (b) visco-elastic foundation including bridge.

If the rail lies on the bridge, flexible deflection of the bridge influences on the rail position that calculates as a sum of the displacement of the rail relatively to the bridge and the flexible deflection of the bridge in the correspondent point. Generally the velocity of the K point on the bridge is not zero.

UM VBI tool considers the flexibility of the bridge while calculating contact forces between wheels and rails and lets the user a possibility to analyze bridge dynamics taking into account moving load caused by the railway vehicle through the rail.

Computer simulation is an effective approach to analyze the dynamics of railway bridges under train motion along them. The main object of investigations can be both a bridge and a railway vehicle.

Let us discuss two typical approaches for analysis of vehicle-bridge interaction and stress-strain state of a bridge: separate and coupled approaches. So called separate approach is the typi-

cal one that is used in many papers. It supposes considering a dynamical model of a railway vehicle and a model of a bridge separately. It means that wheel-to-rail contact forces are obtained from the simulation of a railway vehicle without taking into account the vehicle-bridge interaction. As a result of the dynamical analysis, time histories of contact forces are saved. Then the obtained wheel-to-rail contact forces are applied to the FE-model of a bridge as running loads at the points that correspond to positions of wheels, Figure 1.2. Since vehicle dynamics is simulated without any reference to a bridge, the separate approach cannot give us any vehicle-related performances like safety, stability or ride comfort that would describe exactly vehicle-bridge interaction. So the separate approach can be used as a good approximation for the bridge response, but it is completely useless with regard to obtaining the vehicle dynamical response to running through the bridge.

The so-called coupled approach supposes the mutual vehicle-bridge dynamics. Total displacements of rails are obtained as a sum of displacements between the rail and the bridge due to sleepers and roadbed and flexible displacements of the bridge itself. The obtained total displacements finally influence the contact wheel-to-rail forces that in fact act on wheelsets and the bridge and thereby coupled vehicle and bridge dynamics. So the coupled approach connects vehicle and bridge models in the integrated model and

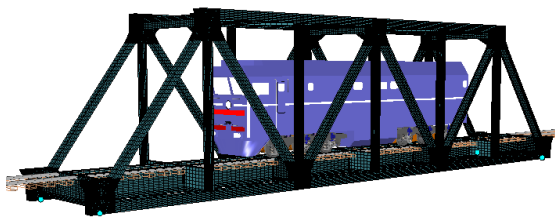

While the railway vehicle is moving on the bridge the following algorithm is performed on each step of numerical method.

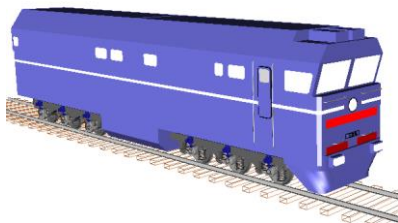

1. Equations of motions of the railway vehicle are generated without taking into account vehicle-bridge interaction.

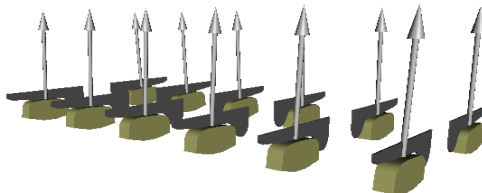

2. Wheel-to-rail forces are calculated.

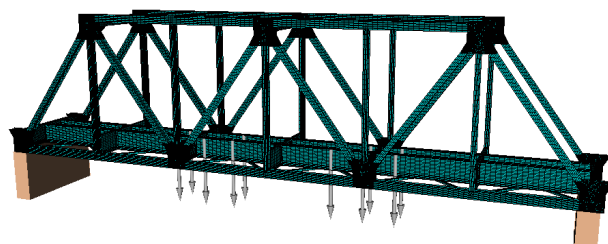

3. The obtained wheel-to-rail forces are applied to the correspondent points on the bridge.

Figure 1.2. Separate approach.

Both approaches suppose the following assumptions:

- both lateral and vertical forces are taking into account;
- vertical forces from each wheel are applied directly;
- lateral forces are averaged for each wheelset.

1.3. Moving load

While railway vehicle is moving on the bridge, the moving load (in fact, wheel-to rail contact forces) acts on the bridge. Attachment points of such moving load correspond to positions of contact patches between wheels and rails.

Load (force) is qualified as *fixed* if coordinates of its attachment point in the local reference frame of flexible bridge changes due to flexible deflections only. All wheel-to-rail forces are not fixed in the local reference frame of flexible bridge and are qualified as *moving*.

For example, such force elements as bipolar force element, linear force element, bushing force element and so on use body-fixed attachment points and are considered as *fixed*. Coordinates of the attachment point in the local reference frame for a rigid body are fixed in some pre-set node of a finite element mesh.

Moving load can be applied to any point on a surface of a flexible body and is not connected with any node. The following two simple algorithms are used: fast search of the point on the surface and reduction the moving force to nodal forces.

The *control area* conception is used for fast searching the point on a bridge that corresponds to wheel-to-rail contact patch. The *control area* is a set of finite elements on a surface of the bridge that includes *control finite element* that currently includes the attachment point, Figure 1.3. When the attachment point goes out of the current control finite element the next one should be among the control area and there is no necessary to check all finite element of the model that makes the algorithms to be pretty fast.

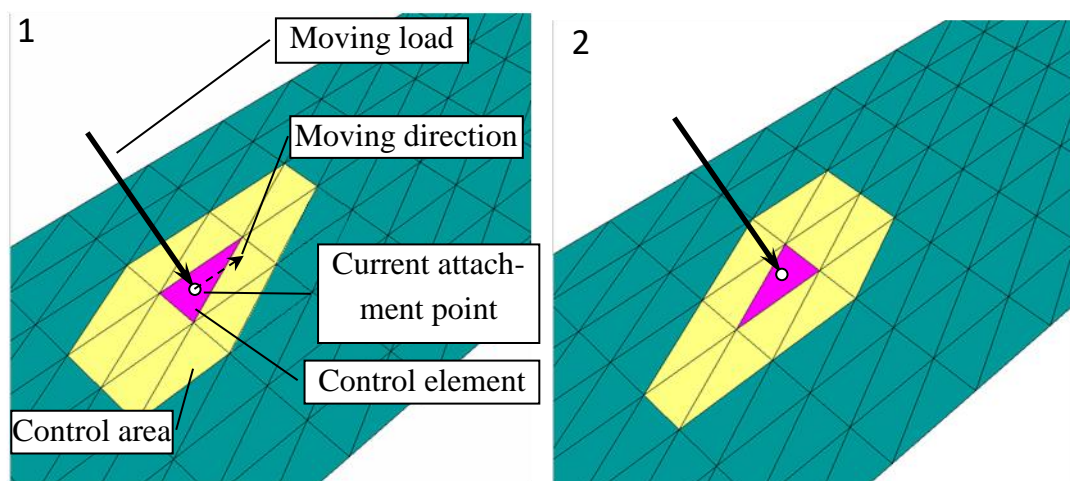

Figure 1.3. Control area for fast determination of the attachment point.

One can visualize *control areas* in animation windows. It will be considered in details in Sect. 1.5. "Simulation of vehicle-bridge interaction", p. 1-14.

Velocity \mathbf{v}_K of an arbitrary point K on the surface is linearly interpolated based on velocities of three nearest nodes that is illustrated in Figure 1.4. Here $\mathbf{v}_1, \mathbf{v}_2, \mathbf{v}_3$ are velocities of nodes in the global frame of reference; $\mathbf{v}_{31}, \mathbf{v}_{21}, \mathbf{v}_{K1}$ are velocities of third and second nodes and K point relative to the first node.

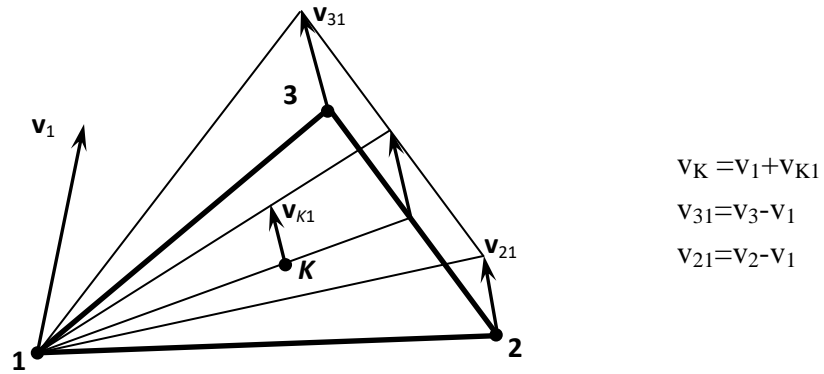

Figure 1.4. On calculation of velocity of an arbitrary point.

Moving load and its reduction to nodal forces can be shown in animation windows on each time-step, see Sect. 1.5. "Simulation of vehicle-bridge interaction", p. 1-14 for details.

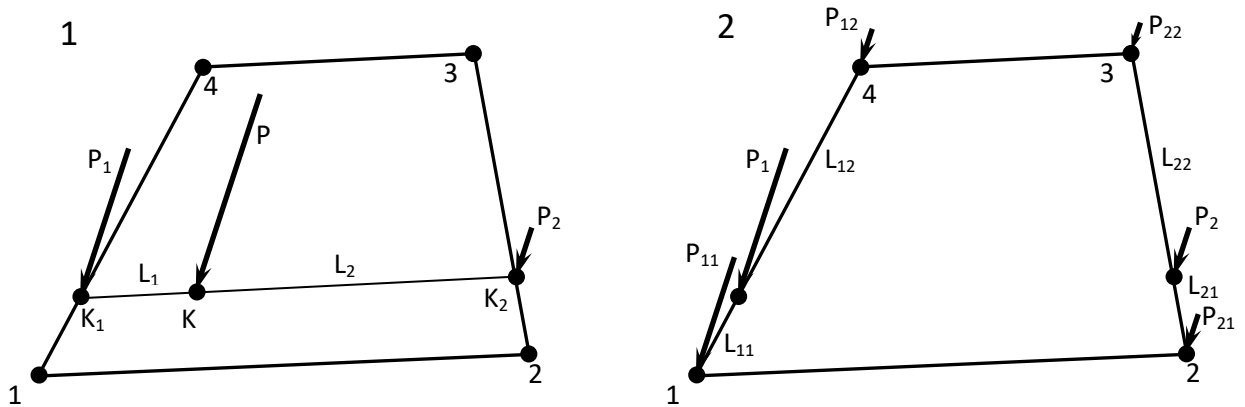

Figure 1.5. Reduction of arbitrary force to nodal forces.

1.4. Preparing the model of flexible bridge

The model of a bridge should be prepared with the rules of preparing the flexible subsystem given in Sect. 1.2. "*Mathematical model of interaction*", p. 1-3 - 1.4. "*Preparing the model of flexible bridge*", p. 1-8. Besides that rules, the model should meet the following requirements.

1. The longitudinal direction of the bridge should be oriented along the X-axis of the global frame of reference.
2. The plane of the bridge on which the rails are mounted should coincide with XY plane of the global frame of reference.
3. In order for UM to consider the subsystem as railway bridge, the subsystem comment should contain key string `@rwbridge=true@` in any place, no case sensitive. For example, "The subsystem simulates trestle bridge 60 meters in length `@rwbridge=true@`".
4. It is strongly recommended that the railway vehicle or first vehicle of the train should be positioned 5 meters as minimum from the nearest end of the bridge to avoid unwanted transient processes at the moment of the beginning of the simulation.

Let us consider some features related to description of the flexible bridge with the help of the sample UM-model. You can download the TGV_Bridge model from the Internet using the following link: http://www.universalmechanism.com/download/samples/um_samples_vbi.zip.

Bridge span is introduced as a flexible subsystem **Bridge**. It is rested on three piers in nine points, three points per pier. Nine joints of **6 d.o.f.** type were introduced. Joints on the 1st pier are ball ones and restrict all translational degrees of freedom. Joints on the 2nd and 3rd piers restrict only vertical and lateral d.o.f. and have longitudinal d.o.f.

UM model, presented in Figure 1.6, does not include piers as rigid bodies but includes them as graphical objects only for illustrativeness. The graphical object, that includes all three piers, are assigned with the scene (**Base0** body in terms of UM). Interface nodes of the flexible bridge are given in Figure 1.7. Coordinates of joint points in local frame of reference of flexible subsystem **Bridge** are given in Table 1.1. Graphical object **Bridge footing** is shown in Figure 1.8. Graphical object **3 bridge footing** that represents three piers includes graphical object **Bridge footing** three times.

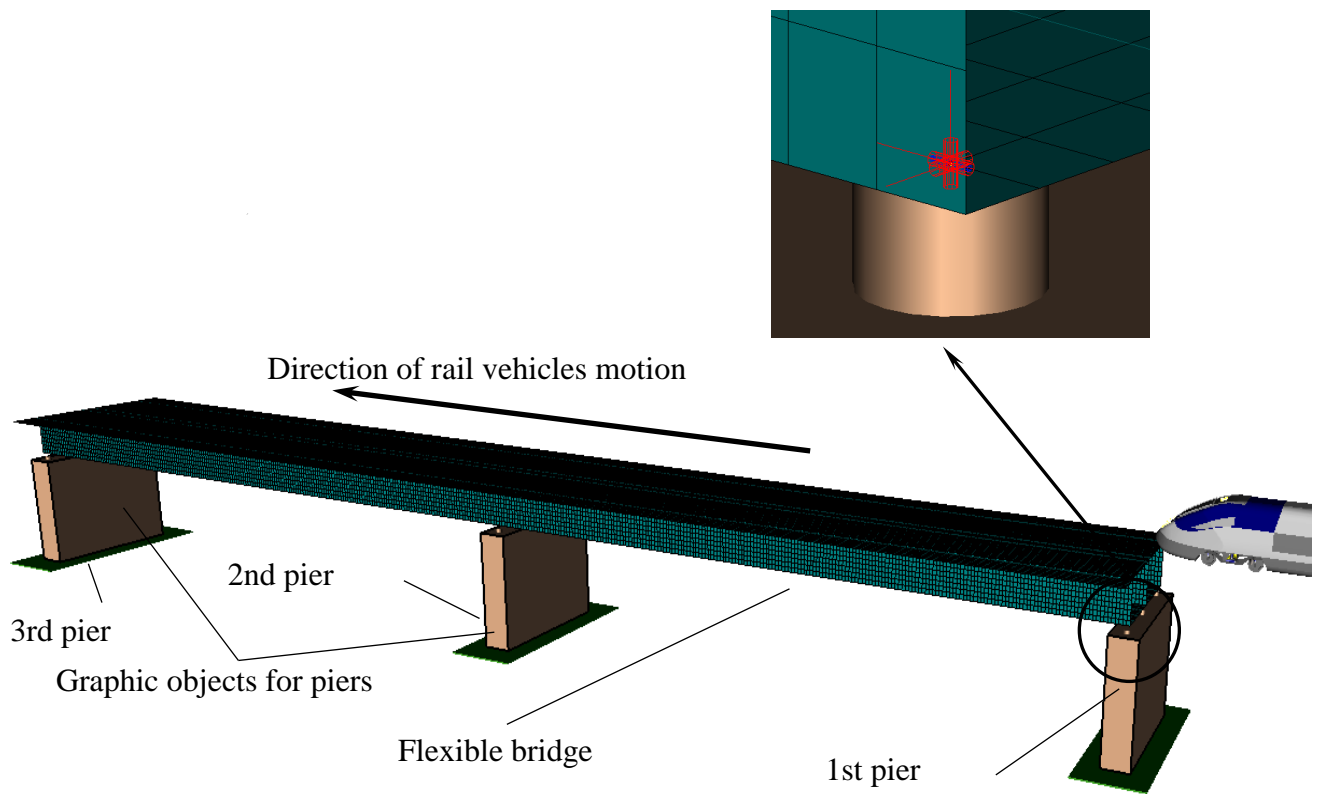

Figure 1.6. Bridge model

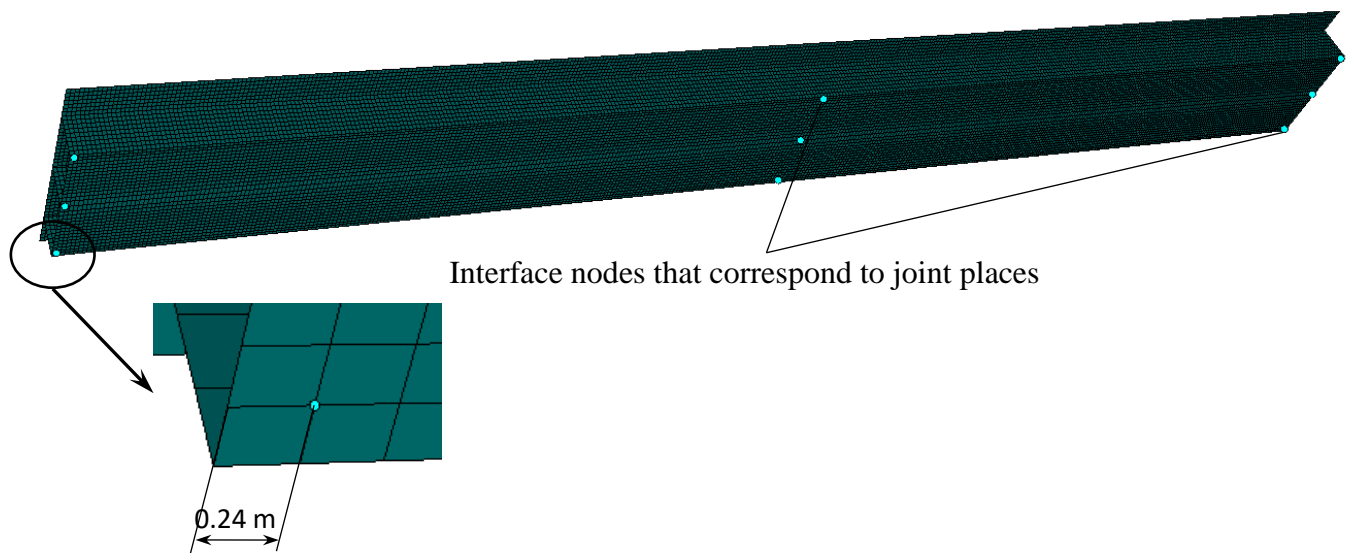

Figure 1.7. Interface nodes of flexible subsystem Bridge.

Table 1.1

Coordinates of joint points in local frame of reference of Bridge subsystem

No	X	Y	Z	Comment
1.	47.76	4.185	-1.66	3rd pier, left joint
2.	47.76	0.000	-1.66	3rd pier, middle joint
3.	47.76	-4.185	-1.66	3rd pier, right joint
4.	0.00	4.185	-1.66	2nd pier, left joint
5.	0.00	0.000	-1.66	2nd pier, middle joint
6.	0.00	-4.185	-1.66	2nd pier, right joint
7.	-47.76	4.185	-1.66	1st pier, left joint
8.	-47.76	0.000	-1.66	1st pier, middle joint
9.	-47.76	-4.185	-1.66	1st pier, right joint

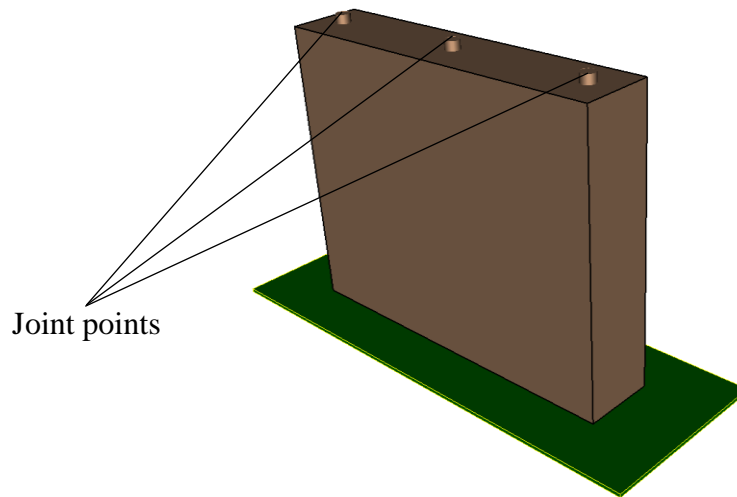

Figure 1.8. Graphical object **Bridge footing**.

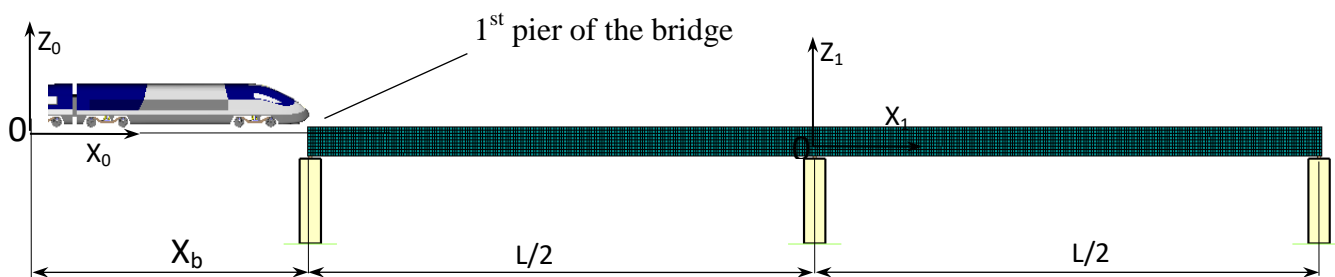

Figure 1.9. Position of **Bridge** subsystem in the railway track.

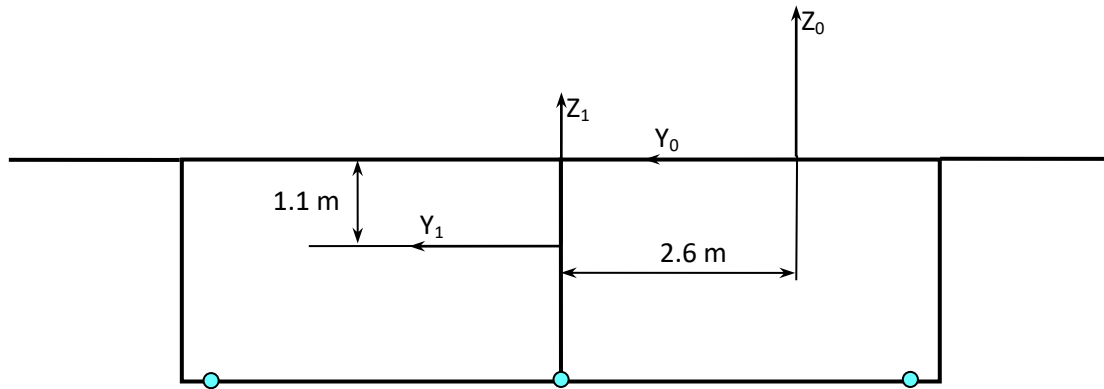

Figure 1.10. Bridge cross section and position of the local frame of reference.

It might be useful for multivariant calculation with varying longitudinal bridge position relative to the initial vehicle position. It is recommended to describe a model in such a way to have a possibility to move the bridge along the track quickly. Let us introduce the following three variables to set the longitudinal bridge position.

UM model parameter	Value	Comment
BridgeXBeginning	$X_b=10$ m	Distance from the origin of the global frame of reference to the 1st pier of the bridge.
ShiftXBridge	$X_b+L/2=10+48=58$ m	Longitudinal (X) shift of the bridge in SC0
ShiftYBridge	2.6 m	Longitudinal (Y) shift of the bridge in SC0
ShiftZBridge	-1.1 m	Longitudinal (Z) shift of the bridge in SC0

The model of a double-track bridge is considered here. The bridge should be moved along lateral Y axis to match the railway track (**X**-axis) in UM model and the right track of the bridge. **Z**-axis shift places the upper contact plane of the bridge in **XY**-plane of SC0.

In the figures below you can see the position of the subsystem (Figure 1.11), the position of graphical object (Figure 1.12) and coordinates of the left joint on the 1st pier (Figure 1.13, Figure 1.6). Parameter **bf_height**, see Figure 1.12, defines the height of the pier. The height of the cylinder at the top is 0.25 m. Finally the longitudinal position of the bridge on the track can be easily set with the **BridgeXBeginning** parameter.

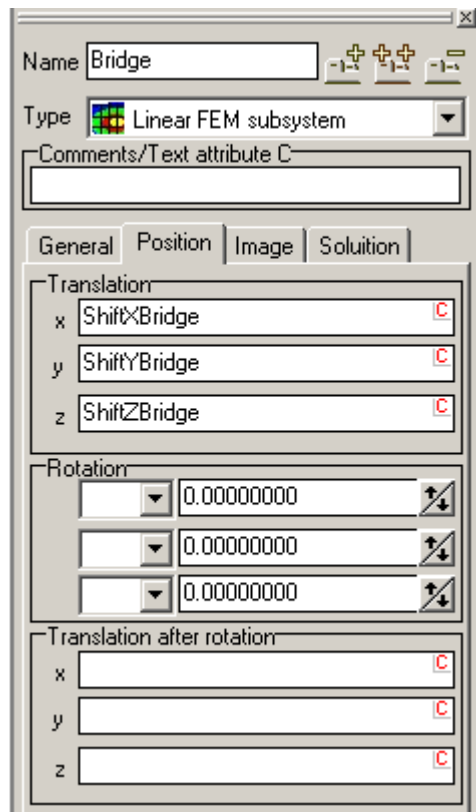

Figure 1.11. **Position** tab of **Bridge** subsystem.

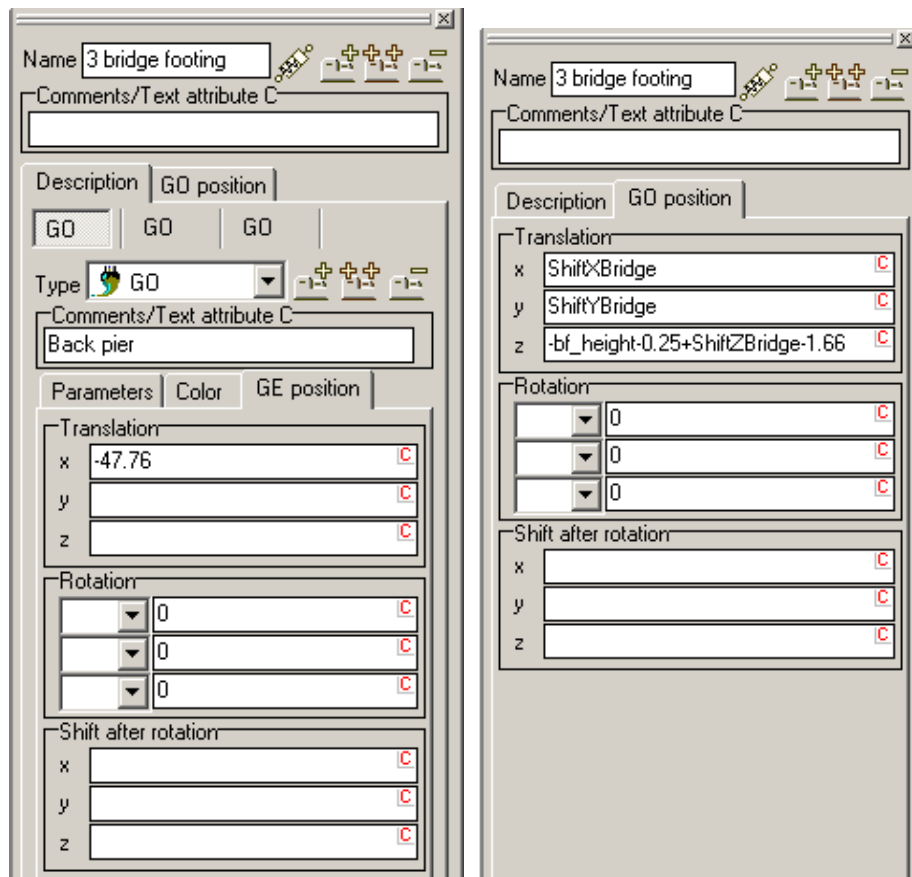

Figure 1.12. Position of the graphical object of the 1st pier (left) and position of **3 bridge footing** graphical object assigned to the scene (right).



Figure 1.13. Coordinates of the joint point of the left joint on the 1st pier in the SC0 (left) and the local frame of reference of the bridge (right).

1.5. Simulation of vehicle-bridge interaction

Let us consider the key features of simulation of vehicle-bridge interaction. If the model includes railway vehicle(s) then **FEM subsystems | Simulation | Railway bridge** tab appears on the parameter window of the flexible subsystem, see Figure 1.14. Flag **Subsystem is railway bridge** switches the flexible subsystem to be considered as a railway bridge.

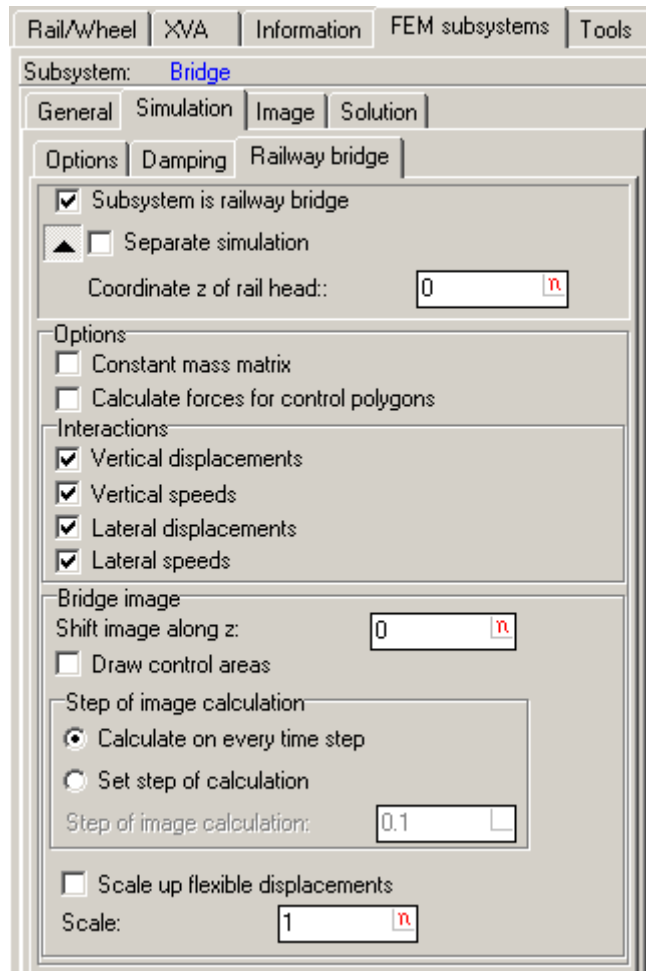

Figure 1.14. Default settings of **Railway bridge** tab.

- Flag **Separate simulation** turns on/off separate/combined approach to simulate vehicle-bridge interaction, see Sect. 1.2. *"Mathematical model of interaction"*, p. 1-3.
- Field **Coordinate z of rail head** corresponds to the lowest point on wheel rolling tread and as a rule is equal to zero. See Sect. 8.2.2 of UM User's Manual for details.

Button  hides/shows additional options. Let us consider them in details.

- **Constant mass matrix.** The flag defines if the mass matrix of the bridge calculates on each simulation step-size. If the FE-model includes many flexible degrees of freedom turning on the flag may help to make the calculations 5-10% faster with keeping practically the same accuracy. When the flag is turned on the mass matrix of the unstrained flexible bridge is used.

- **Calculate forces for control polygons.** The flag turns on/off the visualization of vehicle-bridge interaction forces and visualization of nodal forces. You can also visualize VBI and nodal force forces with the help of following steps.
 1. Open **Wizard of variables**.
 2. Select **User | Vectors** tab, see Figure 1.15. If a UM model includes flexible bridges then the **List of user vectors** has the vectors named according to the following principles.
 - **VBIForce+Number of a wheelset+L(R)**, where VBI means Vehicle-Bridge Interaction, **L(R)** mean left of right wheel of a wheelset.

Example. **VBIForce3R** mean VBI force for the right wheel of the third wheelset of the vehicle.

- Nodal forces have additional index of the node in the control area in the end, **VBI-Force3R.2**, for example.
- 3. You can select necessary vectors (Figure 1.15) and drag them to an animation window.
 - **Interactions.** This group lets the user a possibility to turn on/off considering vertical and lateral displacement and velocities of the points of bridge during the calculation of vehicle-bridge interaction force. By default, all flags are turned on. Turning on/off lets the user a possibility to estimate influence of the correspondent factor on the final solution.
 - **Bridge image.** This group joins some parameters that influence on visualization of the bridge.
 - **Shift image along z** moves the graphical image of the bridge along the vertical direction. In fact, dynamical model of the vehicle-bridge interaction supposes that the contact plane of the bridge coincide with rail heads in vertical direction. This parameter gives us a possibility to prepare visual representation corresponding to reality including ties and rails.
 - **Draw control polygons.** This flag turns on/off the visualization of control areas in animation windows during simulation of system dynamics. A control area corresponds to each wheel of the railway vehicle.
 - **Step of image calculation.** Possible values are **Calculate of every time step** and **Set step of calculation**. By default the image of the deformable bridge are calculated and redrawn on each time step. If the model of the flexible bridge includes many nodes (more than 70 000) and many degrees of freedom (more than 100) then recalculating deformable bridge for visualization takes even more CPU efforts than the simulation of system dynamics itself. It is recommended to use **Step of image calculation** in the interval [0.05÷0.2] seconds to accelerate bridge visualization and finally simulation process.
 - **Scale up flexible displacement.** This flag allows the user to draw the flexible bridge in animation windows applying preset scale for flexible displacements. Since the flexible displacements are normally rather small it is recommended to scale them up to watch them directly. Value bigger than 1 corresponds to increasing the flexible displacements during its animation.

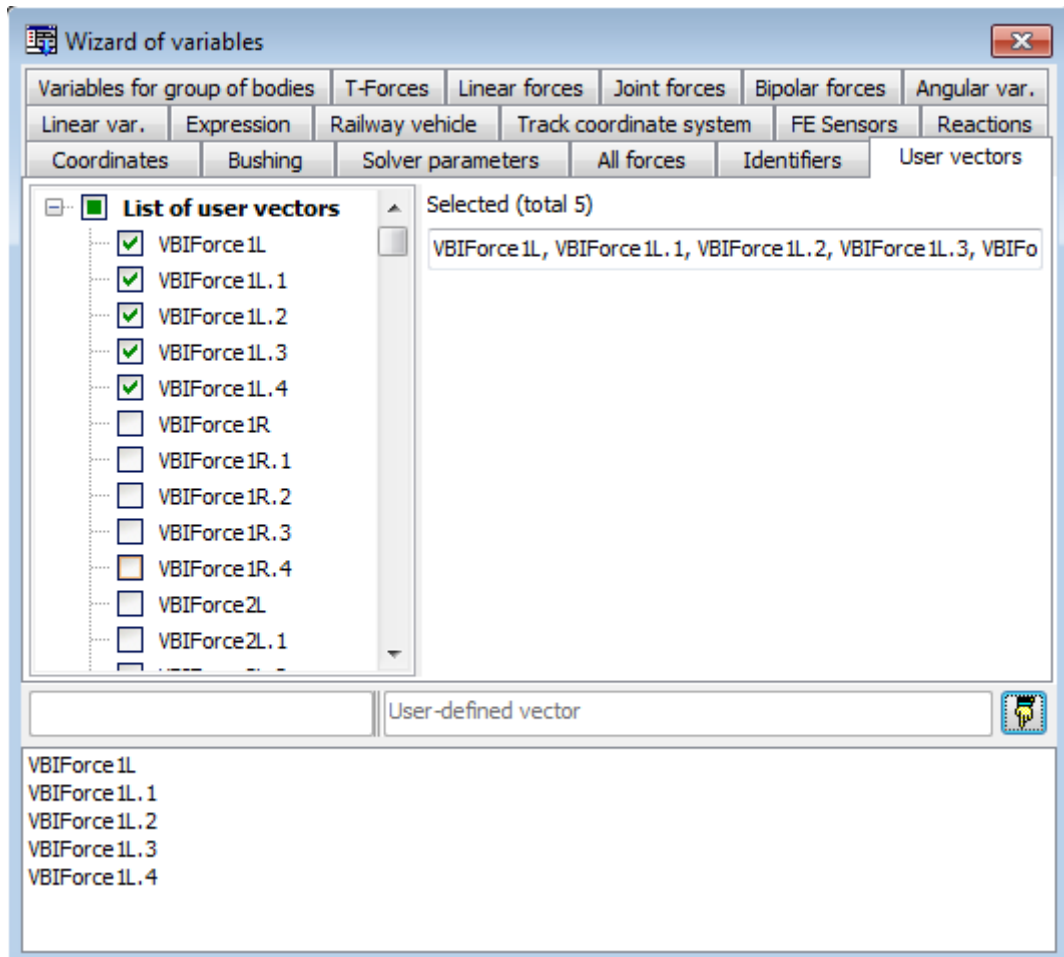

Figure 1.15. On creating the vector of forces of vehicle-bridge interaction.

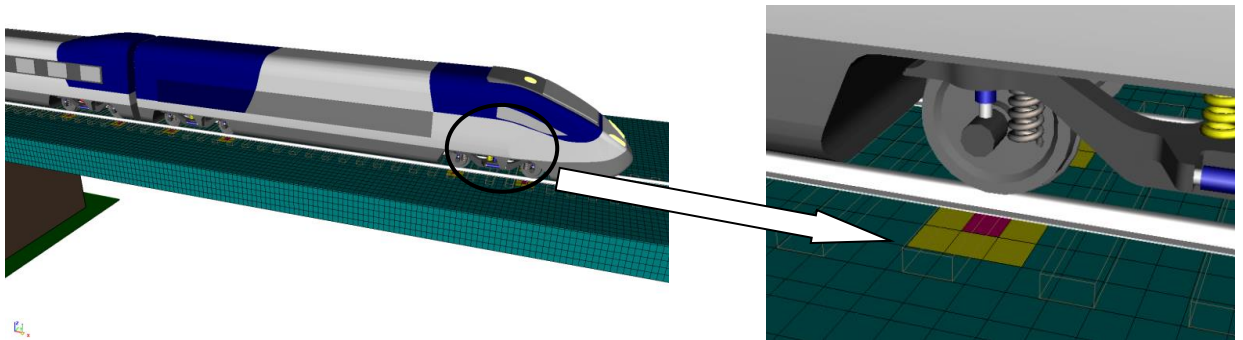

Figure 1.16. Control area in an animation window.

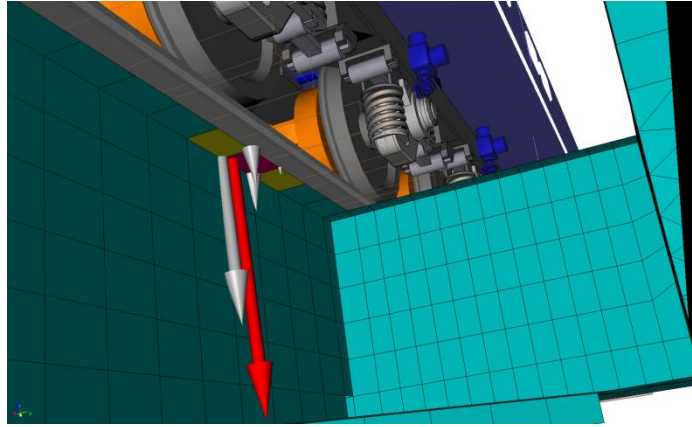

Figure 1.17. Vehicle-bridge interaction force and its reduction to nodal forces.

1.6. Sample model

Let us consider the sample model of the high-speed train which is moving on the flexible bridge, see Figure 1.18. You can download the TGV_Bridge model from the Internet using the following link: http://www.universalmecanismo.com/download/samples/um_samples_vbi.zip. The bridge model is described in details in Sect. 1.4. "Preparing the model of flexible bridge", p. 1-8.

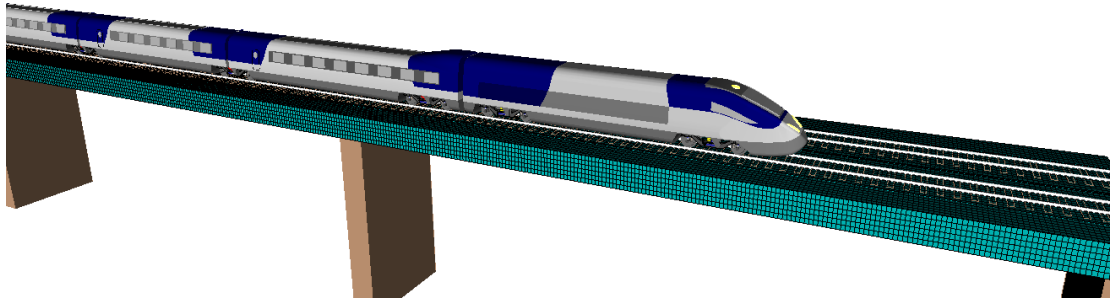

Figure 1.18. High-speed train on the bridge.

Let us briefly consider the train model. The model is based on TGV-KTX parameters, includes motor, motor-trailing and trailing cars, see Figure 1.19, Figure 1.20. The model has 294 d.o.f. Total mass of the train is 438 tons.

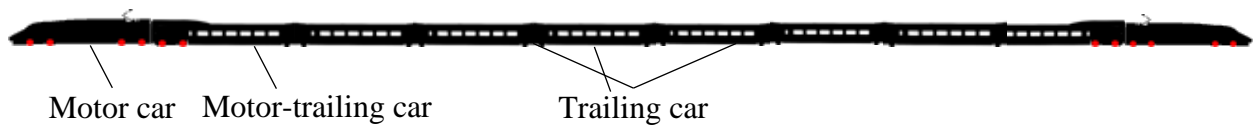
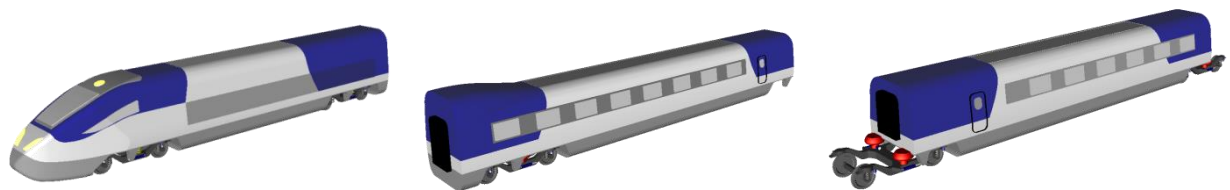

Figure 1.19. 10-car model of high-speed TGV-KTX train.



Motor car, 68 tons

Motor-trailing car, 48 tons

Trailing car, 33.5 tons

Figure 1.20. Vehicle models from the TGV high-speed train.

The list of variables that is distributed along with the model includes the following variables:

- vertical and lateral displacements of points that are situated on the top plane in the middles of each span;
- longitudinal stresses in the same points (nodes);
- vertical and lateral wheel-to-rail forces for the wheels of the first motor car;
- safety factor (Nadal criterion) for the same wheels.

Configuration of the model including desktop windows, model parameters, solver parameters, are saved in **tg_v_bridge.icf**.

To try the model, go through the following steps:

- run **UM Simulation**;
- load the configuration file using **File | Load configuration | tgv_bridge** menu item;
- click **Analysis / Simulation** menu item or press **F9** key;
- run simulation of system dynamics using **Integration** button or **F9** key;
- analyze obtained results.

Basic simulation tools are described in details in Sect. 4.3.4-4.3.8 of UM User's Manual. You can always create some more variables to analyze with the help of Wizard of variables, see Sect. 4.3.2.