

Flexible Railway Track

Interaction of railway vehicles and flexible railway track, which is simulated with different levels of details, is described in the present chapter

Contents

27. UM FLEXIBLE RAILWAY TRACK: INTERACTION OF RAILWAY VEHICLES AND TRACK	27-3
27.1. GENERAL INFORMATION.....	27-3
27.2. TRACK MODELS.....	27-3
27.3. MATHEMATICAL MODEL OF THE FLEXIBLE RAIL	27-5
27.4. CREATING FLEXIBLE RAILWAY TRACK IN UM INPUT	27-7
27.4.1. «Flexible railway track» subsystem	27-7
27.4.2. Finite element model of foundation	27-7
27.5. SIMULATION OF RAILWAY VEHICLE DYNAMICS IN UM SIMULATION.....	27-7
27.5.1. Flexible track description.....	27-8
27.5.2. Flexible railway track parameters	27-9
27.5.2.1. Parameters of rails	27-9
27.5.2.2. Parameters of sections	27-11
27.5.2.2.1. General parameters.....	27-11
27.5.2.2.2. Parameters of rail pads and fasteners.....	27-14
27.5.2.2.3. Sleeper models and its parameters.....	27-14
27.5.2.2.3.1. Rigid semi-sleepers	27-14
27.5.2.2.3.2. Flexible sleepers.....	27-15
27.5.3. Simulation.....	27-15
27.5.3.1. Choosing the track model	27-15
27.5.3.2. Preparing for simulation	27-16
27.5.3.3. Kinematic characteristics of flexible rails.....	27-18
REFERENCES.....	27-20

27. UM Flexible Railway Track: interaction of railway vehicles and track

27.1. General information

UM Flexible Railway Track module is aimed to automate creation of the railway track model and simulation of dynamics of interaction between railway vehicles and flexible railway track including flexible FE-models of infrastructure.

UM Flexible Railway Track module requires **UM Loco** module to simulate railway vehicle dynamics and **UM Loco / Multi-point Contact Model** tool to simulate contact interaction between railway wheels and flexible track. **Multi-point Contact Model** the only contact model that supports **Flexible Railway Track**. To simulate the interaction of the flexible railway track and the FE-model of the infrastructure (bridges, overpasses, tunnels etc.) **UM FEM** module is required.

Make sure that all required UM modules are available. Check it with the menu command **Help | About**, see Figure 27.1.

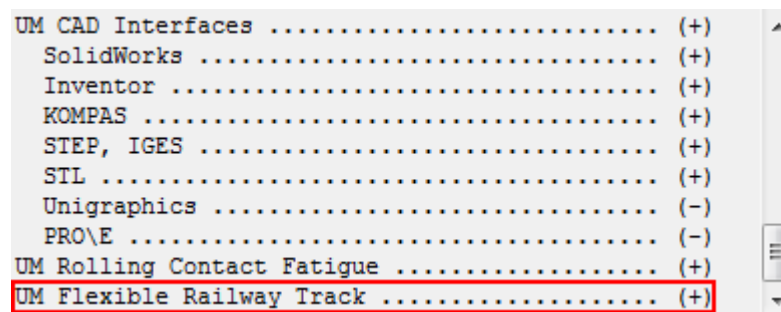

Figure 27.1. Current UM configuration in **About** window

27.2. Track models

Universal Mechanism supports three track models that consider track with different level of details:

- **Massless rail;**
- **Inertial rail;**
- **Flexible track.**

Massless rail track model treats rail as a massless force element. For such a rail model generalized coordinates are not introduced. Rail deflections are calculated as a result of solution of equilibrium equations ([Chapter 8](#), Sect. "Method for computation of rail deflections and contact force"). This model is recommended to use for analysis/optimization of running gears of railway vehicles since intrinsic rail dynamics weakly effects on simulation results of rail vehicles. **Massless rail** model is used as the default track model.

Inertial rail track model considers rails as rigid bodies under each wheel, see Figure 27.2. Every rigid body that simulates inertial rails has three degrees of freedom: two longitudinal d.o.f. relative to lateral (Y) and vertical (Z) axes and one rotational d.o.f. relative to longitudinal (X)

axis. Equations of motion for inertial rails are given in track coordinate system ([Chapter 8](#), Sect. "Track system of coordinates"). Underrail base is modelled as a *Special force* of **Bushing** type. **Inertial rail** model is recommended to use for simulation of complex scenario of wheel-to-rail contact: railway track evolution in the switches and turnouts, flange-back and conformal contacts, simulation of vehicle derailment cases, prediction of wheel and rail wear, etc.

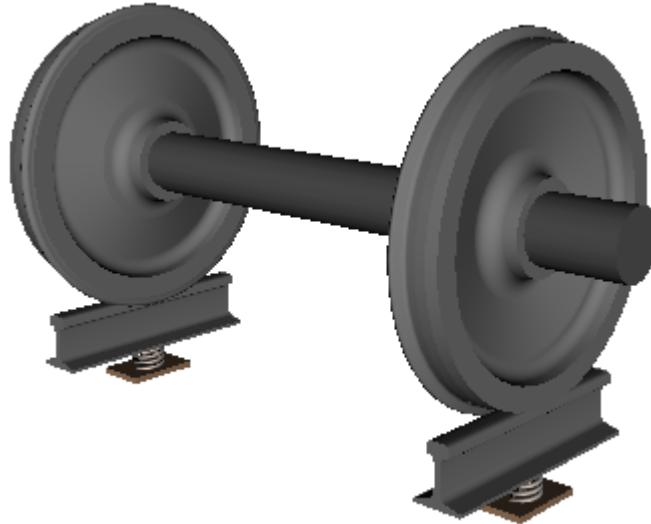

Figure 27.2. **Inertial rail** track model

Flexible track model is a detailed 3D track model that includes flexible rails, fasteners, sleepers and sleeper foundation. Rails are considered as Timoshenko beams. Fasteners are modelled as a *Special force* of **Bushing** type. Sleepers are simulated as rigid bodies (Figure 27.3) or flexible beams (Figure 27.4). The second option – simulation sleepers as flexible beams – is not supported in the current **UM Flexible railway track** release.

If sleepers are simulated as rigid bodies (Figure 27.3) then sleeper foundation is simulated with the help of a *Special force* of **Bushing** type that connect semi-sleepers with the rigid base or finite element flexible foundation. The second model considers ballast as an elastic foundation that simulates vertical reaction and a bipolar force that simulates lateral forces acting from the ballast to the sleeper at its lateral displacement.

Flexible track model is recommended for problems that are focused on dynamics of the railway track and railway track foundation. In **Flexible track** model can using finite element models as elements of track foundation (bridges, overpasses, tunnels etc.).

Listed above track models **Massless rail**, **Inertial rail** and **Flexible track** treat sequentially more and more complex models and approaches to simulation railway track. In fact, more complex models provide more accurate results but require more CPU efforts. The following rough estimations of relative CPU efforts while using different track models might be given. **Inertial rail** is about 2-3 times slower and **Flexible track** model is about 50-80 times slower than **Massless rail** model.

Please note that the frequency range for **Massless rail** model is 0-20 Hz. **Inertial rail** provides reliable simulation in the frequency range up to 100 Hz, and **Flexible track** – up to 1000 Hz.

Inertial rail and **Flexible track** models provide railway track kinematics (rail/sleeper position, speed, acceleration). Besides, that **Flexible track** model provides estimates of stresses and strains in flexible bodies (rails, sleepers, bridges).

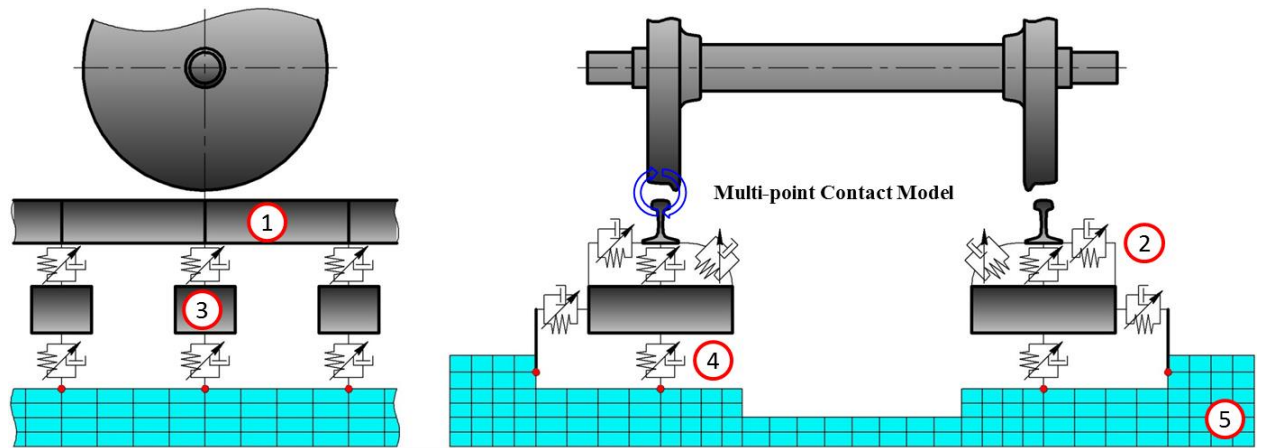

Figure 27.3. Flexible track model with rigid semi-sleepers
 1 is rail, 2 is fasteners, 3 is semi-sleepers, 4 is semi-sleeper pads, 5 is rigid/flexible foundation.

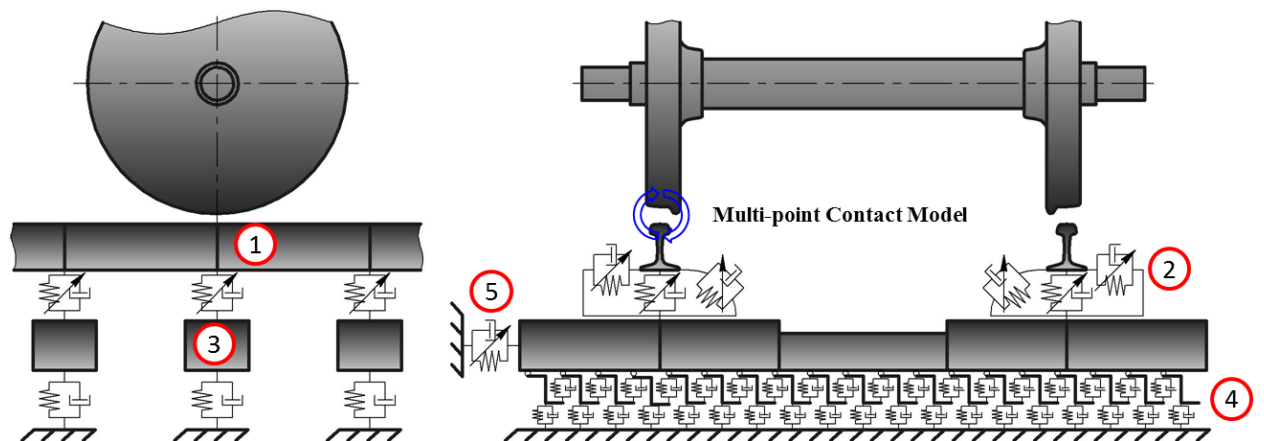

Figure 27.4. Flexible track model with flexible sleepers
 1 is rails, 2 is rail pad/fasteners, 3 is sleeper, 4 and 5 are ballast model.

27.3. Mathematical model of the flexible rail

In **UM Flexible Railway Track** module the finite-element approximation of the following system of differential equations is used:

$$\left\{ \begin{array}{l}
 EA \frac{\partial^2 u}{\partial x^2} - \rho A \frac{\partial^2 u}{\partial t^2} = F_x(t) \delta[x - x_w(t)] + \sum_{i \in \mathbb{N}} \delta(x - x_i^s) F_{x_i}^f(t) \\
 k_y AG \left(\frac{\partial^2 v}{\partial x^2} - \frac{\partial \theta}{\partial x} \right) - \rho A \frac{\partial^2 v}{\partial t^2} - \rho z_s A \frac{\partial^2 \varphi}{\partial t^2} = F_y(t) \delta[x - x_w(t)] + \sum_{i \in \mathbb{N}} \delta(x - x_i^s) F_{y_i}^f(t) \\
 k_z AG \left(\frac{\partial^2 w}{\partial x^2} + \frac{\partial \psi}{\partial x} \right) - \rho A \frac{\partial^2 w}{\partial t^2} + \rho y_s A \frac{\partial^2 \varphi}{\partial t^2} = F_z(t) \delta[x - x_w(t)] + \sum_{i \in \mathbb{N}} \delta(x - x_i^s) F_{z_i}^f(t) \\
 EJ_y \frac{\partial^2 \psi}{\partial x^2} - k_z AG \left(\frac{\partial w}{\partial x} + \psi \right) - \rho J_y \frac{\partial^2 \psi}{\partial t^2} = 0 \\
 EJ_z \frac{\partial^2 \theta}{\partial x^2} + k_y AG \left(\frac{\partial v}{\partial x} - \theta \right) - \rho J_z \frac{\partial^2 \theta}{\partial t^2} = 0 \\
 EJ_\omega \frac{\partial^4 \varphi}{\partial x^4} - GJ_x \frac{\partial^2 \varphi}{\partial x^2} - \rho J_\omega \frac{\partial^4 \varphi}{\partial x^2 \partial t^2} + \rho z_s A \frac{\partial^2 v}{\partial t^2} - \rho y_s A \frac{\partial^2 w}{\partial t^2} + \rho J_p \frac{\partial^2 \varphi}{\partial t^2} = \\
 = \delta[x - x_w(t)] M_x(t) + \sum_{i \in \mathbb{N}} \delta(x - x_i^s) M_{x_i}^s(t)
 \end{array} \right. \quad (27.1)$$

where E , G are modulus of elasticity and shear modulus, ρ is material density, A is a cross-section area, J_y , J_z are central principal moments of inertia, J_x is St. Venant's torsional constant, J_ω is warping constant, k_y , k_z are shear correction factors in principal planes, J_p is polar moment of inertia, y_s , z_s are coordinates of shear centre relative to centre of gravity in principal central frame of reference (see Figure 27.5), $\delta(\cdot)$ is Dirac delta function, $x_w(t)$ is current longitudinal coordinates of the wheelset, $F_x(t)$, $F_y(t)$, $F_z(t)$, $M_x(t)$ are forces (longitudinal, lateral and vertical) and moment (relative longitudinal rail axis) that act on the rail from the wheel, $F_x^f(t)$, $F_y^f(t)$, $F_z^f(t)$, $M_x^f(t)$ are forces and torques, that act on the rail from fasteners, x_i^s are longitudinal coordinates of sleepers.

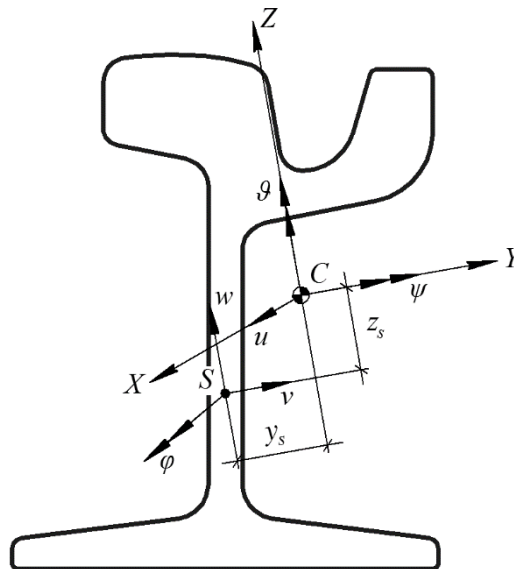

Figure 27.5. Geometry of the rail cross-section, C is a centre of gravity, S is shear centre

27.4. Creating flexible railway track in UM Input

27.4.1. «Flexible railway track» subsystem

Run **UM Input**. Load existing or create new model of a railway vehicle. Select **Subsystems** in the tree of elements on the left and add new **Flexible railway track** subsystem, see Figure 27.6. It is all what you need to create in **UM Input** program. All properties of the flexible railway track are defined in **UM Simulation** program.

Note: In **UM Simulation** program you can easily switch between all possible track models (**Massless rail**, **Inertial rail** and **Flexible track**) without changing model of the railway vehicle itself (Sect. 27.5.3.1 "Choosing the track model").

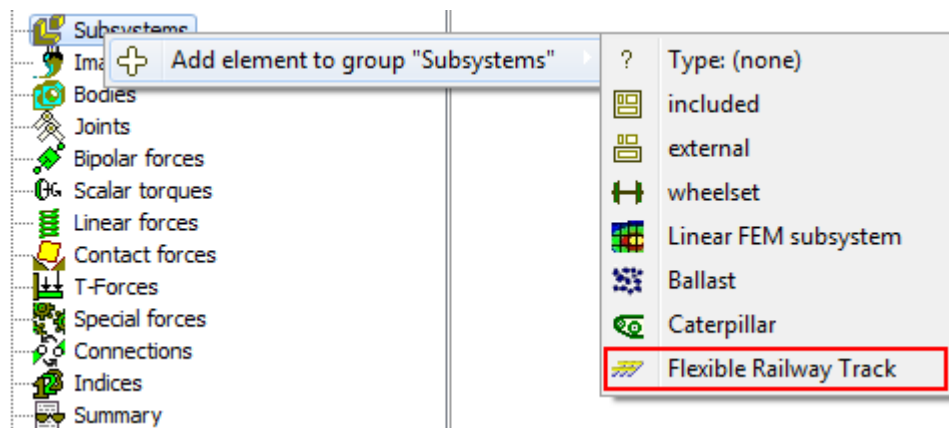

Figure 27.6. Adding new subsystem



27.4.2. Finite element model of foundation

Finite element model of flexible foundation/infrastructure should be prepared according to the general rules of preparing data of flexible subsystem described in [Chapter 11](#). beside mentioned above the following requirements should be satisfied.

- Flexible substructure centre line should coincide with track (macrogeometry) centre line.
- Surface of flexible substructure with what flexible railway track interacts should be parallel to XY plane of the global railway track coordinate system.
- Nodes of finite-element mesh should correspond to positions where flexible railway track interacts with flexible FE substructure.

27.5. Simulation of railway vehicle dynamics in UM Simulation

Use **Tools | Wizard of flexible railway track** menu command to show a dialog window where you can change parameters of the flexible railway track, see Figure 27.7.

-  **Load** parameters of the flexible railway track from *.rwt file;
-  **Save** current parameters of the flexible railway track to *.rwt file;
-  **Generates track model** according to current parameters.

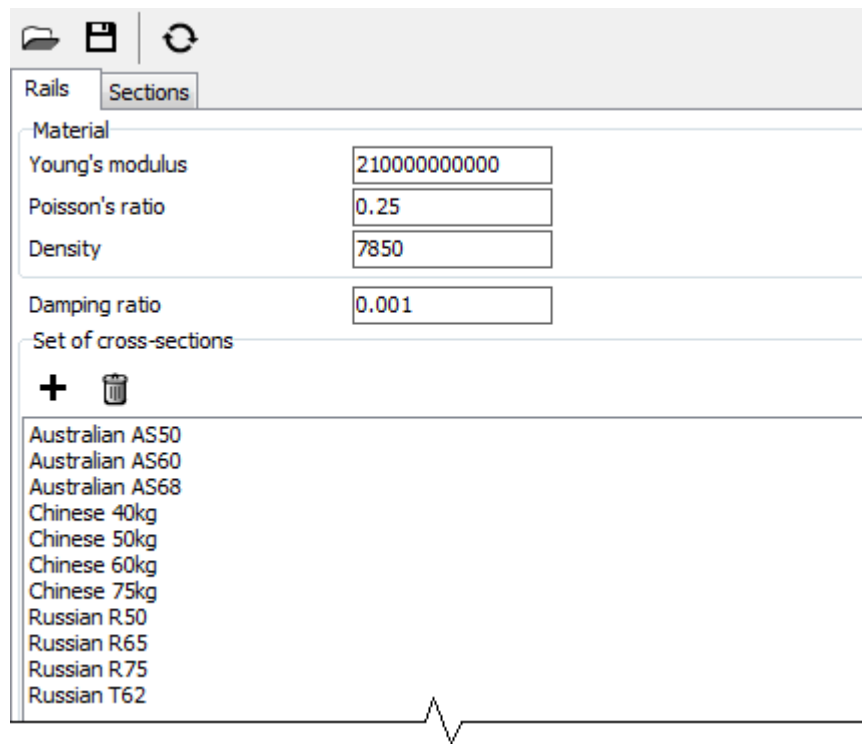

Figure 27.7. Wizard of flexible railway track

Note: Closing the **Wizard** without regenerating track model leads to losing all made changes.

27.5.1. Flexible track description

Flexible railway track is described as a sequence of sections with the constant parameters within the section, see Figure 27.8.

Flexible rails as beam have no breaks on ends of sections and are considered as uniform beams.

Fasteners and sleeper parameters might be changed from section to section. FE-model of flexible foundation should also cover the whole section length. Flexible foundation cannot cover the section length partially.

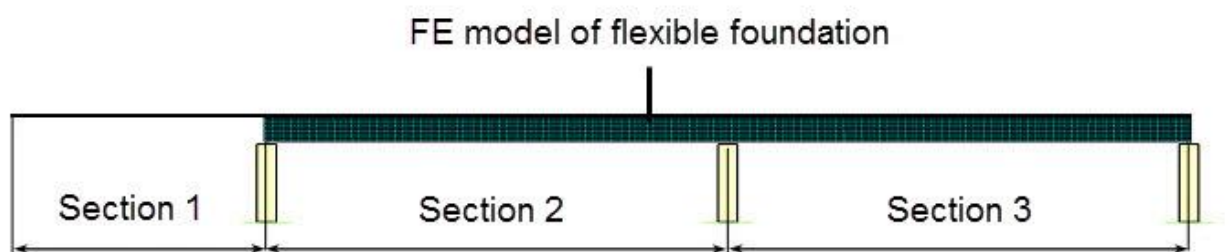

Figure 27.8. Description of flexible railway track in terms of sections

27.5.2. Flexible railway track parameters

27.5.2.1. Parameters of rails

User can change the following parameters of rail materials: **Young's modulus** (modulus of elasticity), **Poisson's ratio** and **Density**, see Figure 27.9.

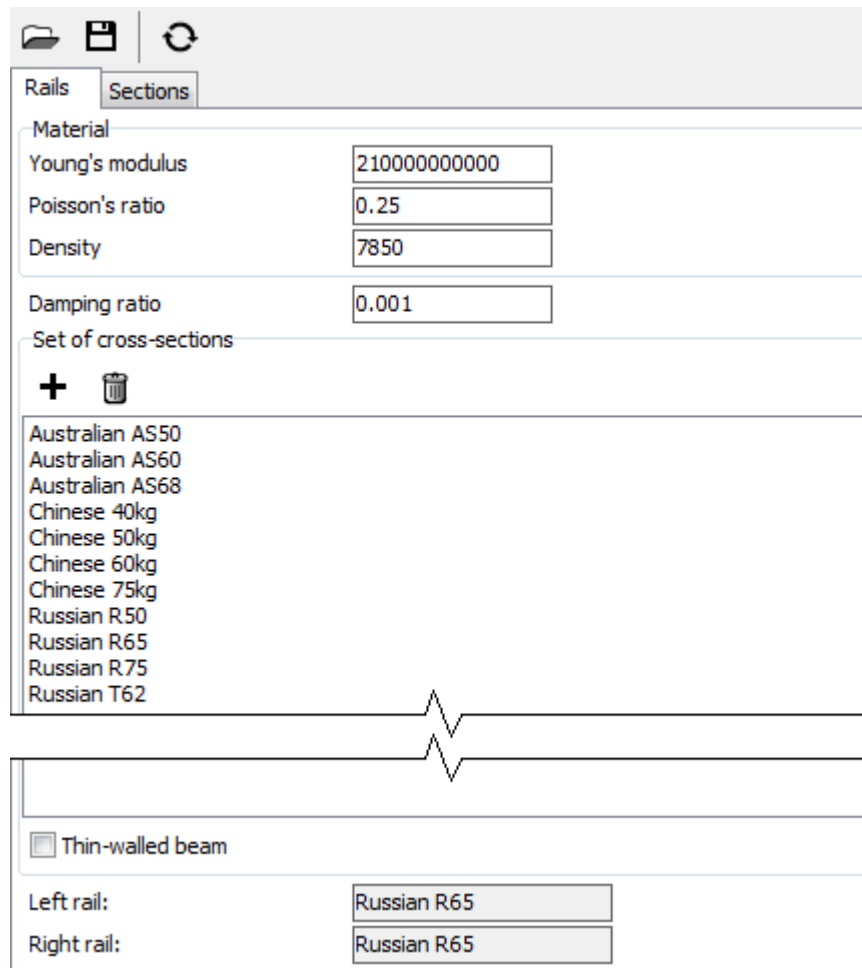

Figure 27.9. Rail parameters

Damping matrix **D** is calculated according to the following formula:

$$\mathbf{D} = \frac{2\xi}{\omega} \mathbf{K}, \tag{1.2}$$

where ξ is a **damping ratio**, ω is the lowest frequency that corresponds to pinned-pinned vibration mode (Figure 27.10), **K** is a stiffness matrix of rail.



Figure 27.10. Pinned-pinned vibration mode

Set of cross-sections includes the list of available rail cross-sections. By default the list has some predefined items. User can add new cross-section using **+** button. Detailed cross-section parameters are given in Table 27.1 and Figure 27.11.

Table 27.1

Rail cross-section parameters

Parameter	Description
Name	Cross-section name
A	Cross-section area [cm ²]
I_y	Moment of inertia relative to Y axis [cm ⁴]
I_z	Moment of inertia relative to Z axis [cm ⁴]
I_{yz}	Product of inertia [cm ⁴]
I_x	St. Venant torsion constant [cm ⁴]
I_ω	Warping constant [cm ⁶]
k_y	Shear correction factor in principal planes Y [-]
k_z	Shear correction factor in principal planes Z [-]
y_s	Coordinate Y of shear centre relative to centre of gravity [cm]
z_s	Coordinate Z of shear centre relative to centre of gravity [cm]
y_h	Coordinate Y central point of rolling surface relative to centre of gravity [cm]
z_h	Coordinate Z central point of rolling surface relative to centre of gravity [cm]
y_f	Coordinate Y central point of rail foot relative to centre of gravity [cm]
z_f	Coordinate Z central point of rail foot relative to centre of gravity [cm]

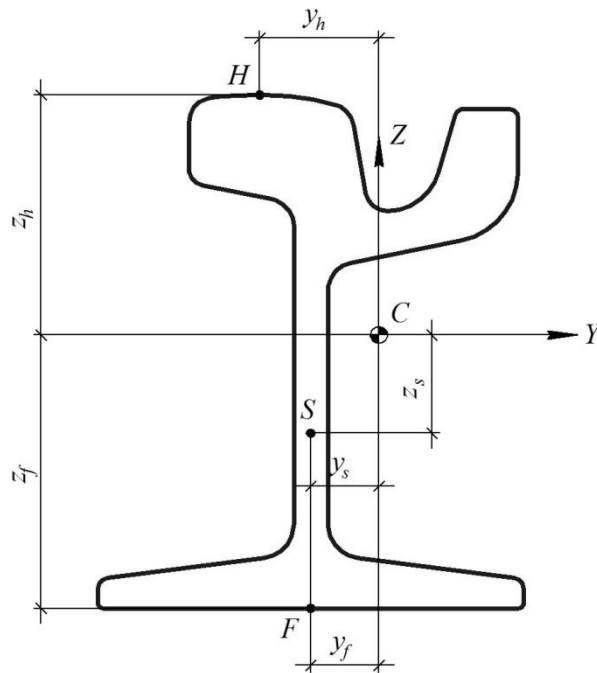

Figure 27.11. Rail cross-section parameters

Note: Y axis should be directed inside the railway track.

Use context menu commands to assign selected cross-section to left, right or both rails, see Figure 27.12.

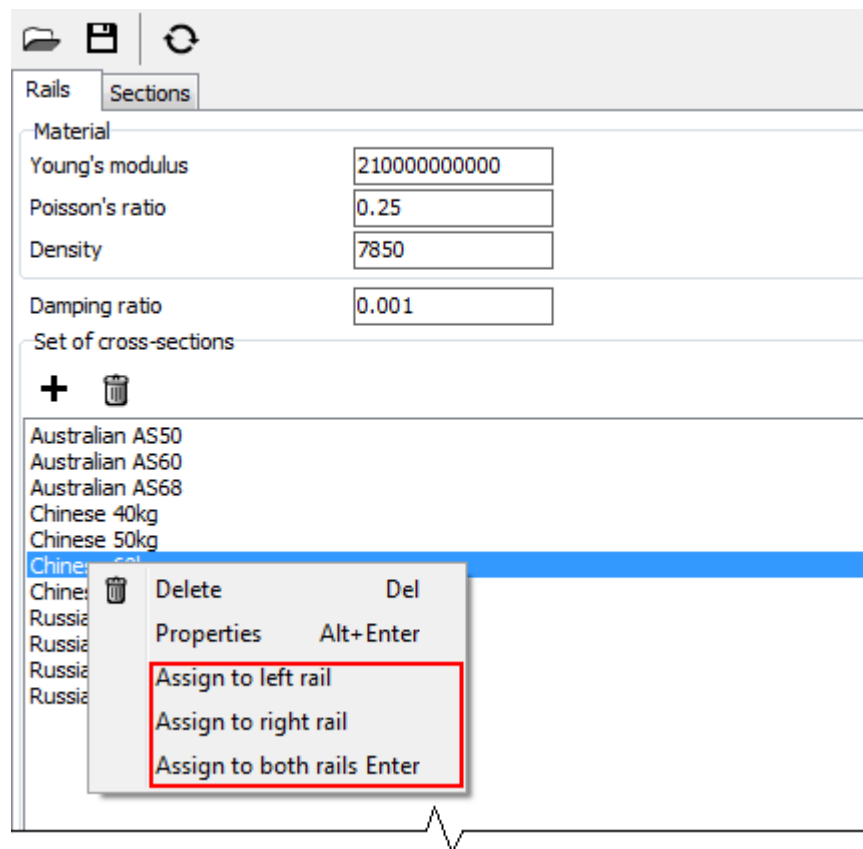

Figure 27.12. Assignment of rail cross-section

Checked **Thin-walled beam** flag turns on considering displacement of shear center relative center of gravity and cross-sectional warping effect.

27.5.2.2. Parameters of sections

Section properties are described in **Sections** tab sheet, Figure 27.13. The tab sheet includes all the sections and the following buttons:

- +** **Add section** to the flexible railway track;
- 🗑** **Delete section** from the flexible railway track;
- 📄** **Duplicate** currently selected **section**.

27.5.2.2.1. General parameters

The following control elements are available on **General** tab:

- **Name** of the current section. It should be unique.
- **Length** of section in count of sleepers;
- **Sleeper spacing** along the track.

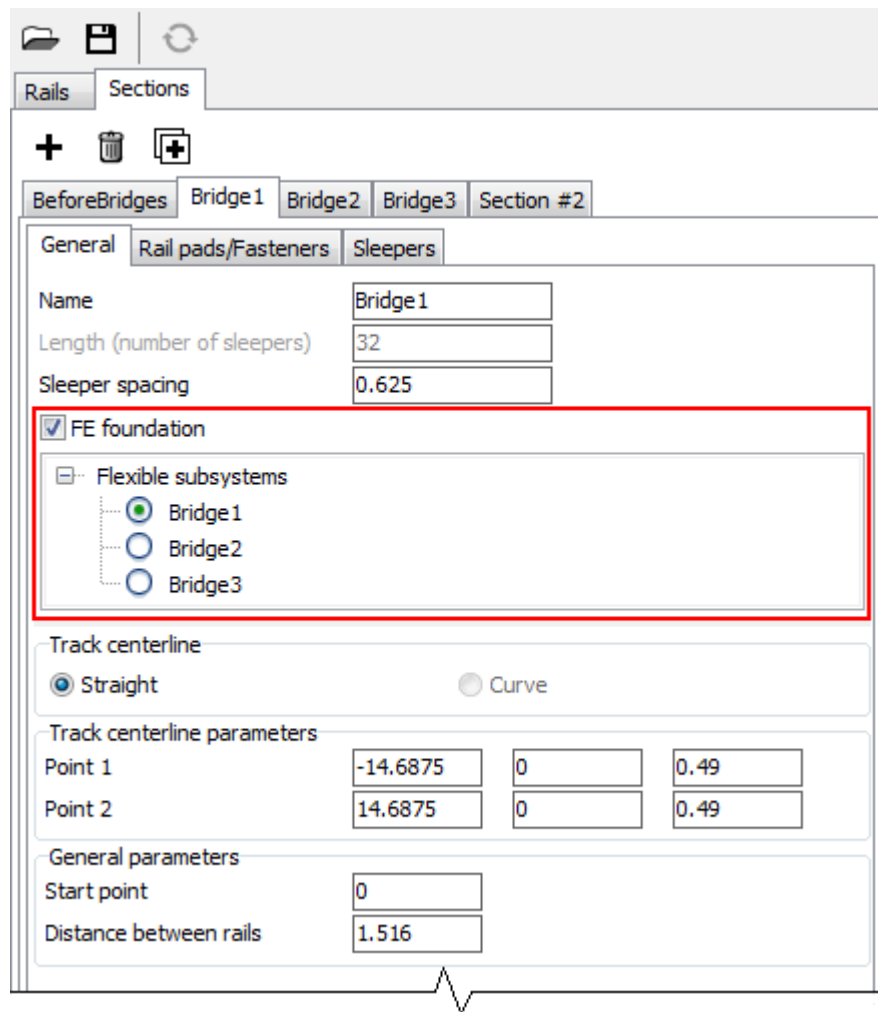

Figure 27.13. **General** parameters of section

If the section interacts with the flexible FE substructure (foundation) then you should turn on **FE foundation** check box and select the correspondent FE subsystem in **Flexible subsystems** list. There are three groups where parameters described flexible track and flexible substructure interaction are listed: **Track centerline**, **Track centerline parameters** and **General parameters**.

Track centerline defines **Straight** or **Curve** (not available in the present version) centerline.

In **Track centerline parameters** group start and end points of the straight line are defined in the local frame of reference of flexible body.

General parameters group includes **Start point**, which defines the position of the first sleeper on the centerline, and **Distance between rails**, which defines distance between centers of rail foots, see Figure 27.14.

To avoid edge effect it is recommended to set the length of the section prior the flexible FE-foundation (Section 1 in Figure 27.8) according to the following formula:

$$L = L_1 + L_2 + L_3 \tag{1.3}$$

where L_1 is the distance from the first wheelset to the flexible foundation; L_2 is the distance between the first and the last wheelsets of the vehicle; $L_3 = (32 \dots 64)L_s$, here L_s is the sleeper spacing.

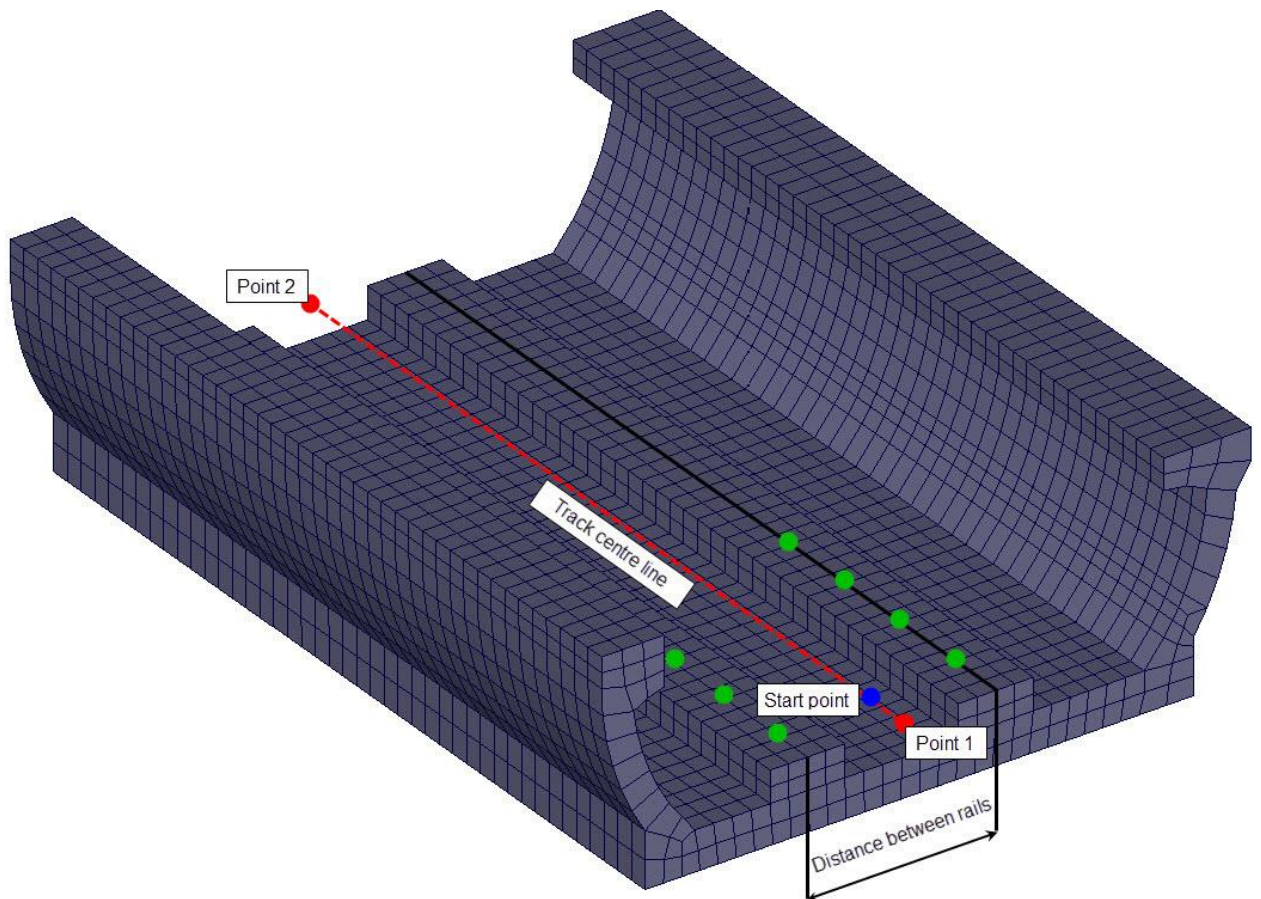

Figure 27.14. Finite element model of flexible foundation

Turn off flag **Set initial speed to v0** for all subsystems that represent FE model of a substructure. Keep the flag turned on for parts of railway vehicle model only: flexible car bodies, flexible bogie frames etc. The flag is situated in **Object simulation inspector | FEM subsystems | Simulation | Options** tab sheet, see Figure 27.15.

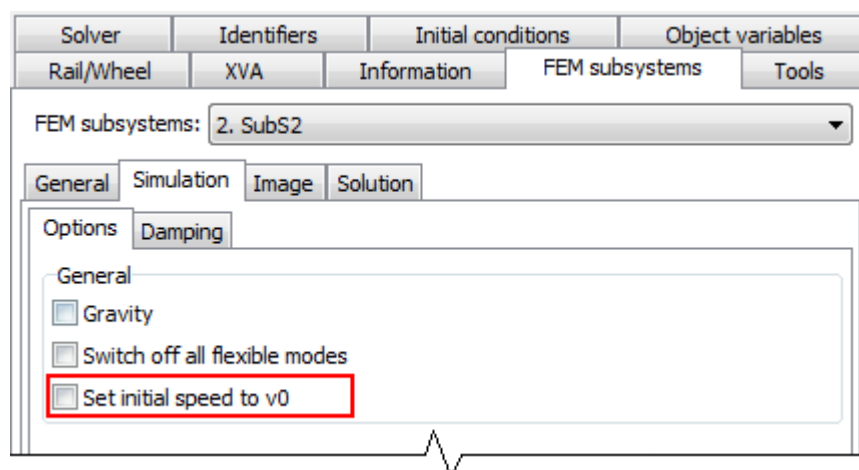

Figure 27.15. Initial speed for flexible substructure

The ready-to-use example of modeling the vehicle-track-bridge interaction can be found in the [{UM Data}\Samples\Flexible railway track\Vehicle-track-bridge_interaction](#) directory.

27.5.2.2.2. Parameters of rail pads and fasteners

Special force of **Bushing** type is used for simulation of rails pads and fasteners. This force model is described in [Chapter 2](#), Sect. "*Bushings*".

27.5.2.2.3. Sleeper models and its parameters

There are two approaches for simulation of sleepers in UM.

- Sleepers are simulated as two rigid bodies that correspond to left and right semi-sleepers. This model is given in Figure 27.3.
- Sleepers are simulated as beams on elastic foundation. This model is described in Figure 27.4.

You may also not consider the sleepers and select **None** as sleeper model. In this case rails will interact with rigid or flexible (as FE-mesh) foundation directly without sleepers in between.

27.5.2.2.3.1. Rigid semi-sleepers

Every rigid semi-sleeper has three degrees of freedom: two translational degrees of freedom relative lateral Y-axis and vertical Z-axis and one rotational degree of freedom relative longitudinal X-axis.

Rigid semi-sleeper is characterized with the following list of parameters (Figure 27.17):

- M is a mass of semi-sleeper;
- I_x is a moment of inertia relative longitudinal X-axis;
- H_1 is the distance between the top of semi-sleeper under the rail and the center of gravity, see Figure 27.16;
- H_2 is the distance between the center of gravity and bottom of semi-sleeper, see Figure 27.16.

To simulate sleeper bearing the special force of **Bushing** type is used, see [Chapter 2](#), Sect. "*Bushings*".

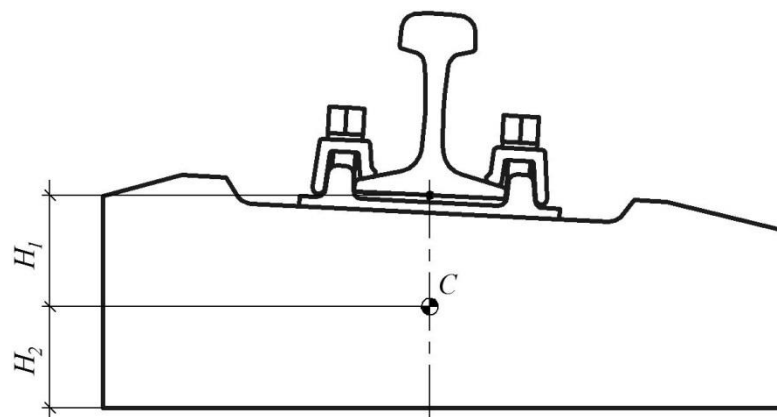

Figure 27.16. Parameters of rigid semi-sleepers

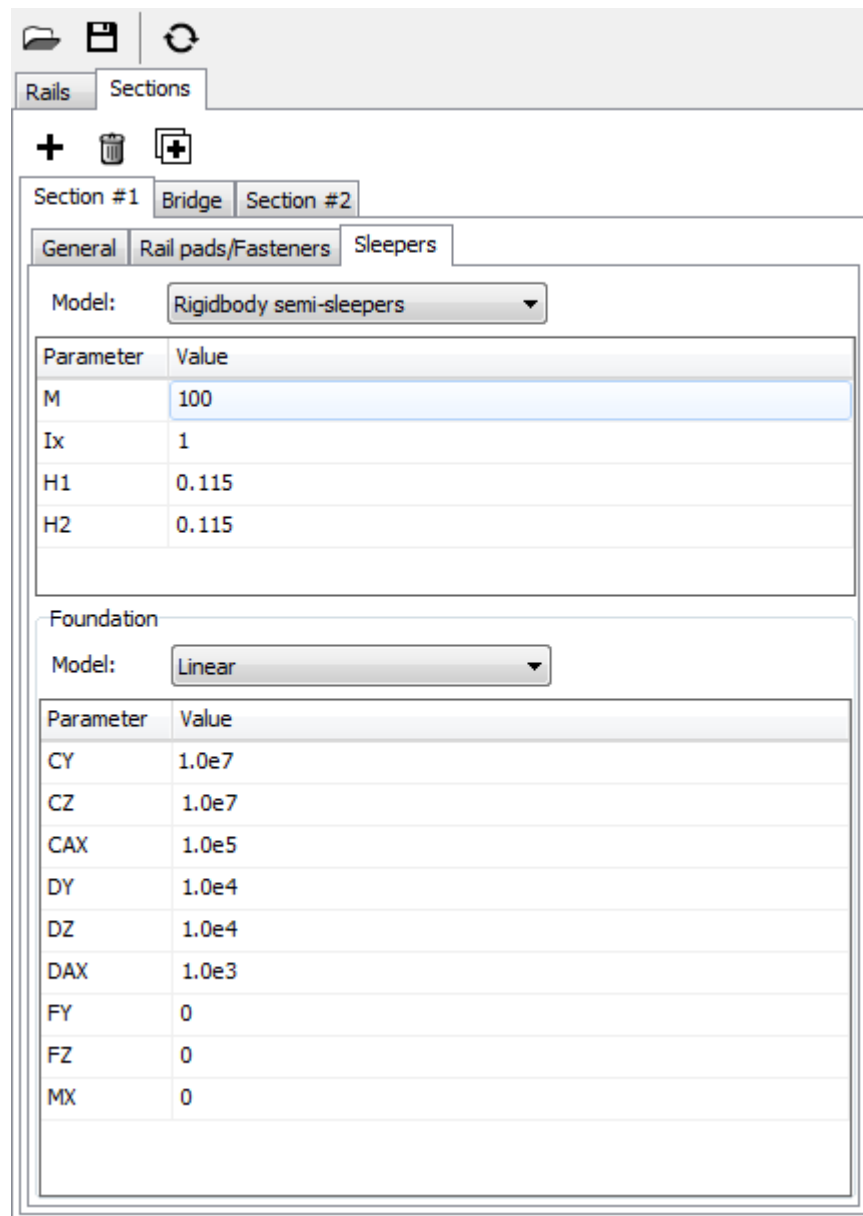

Figure 27.17. Parameters of rigid semi-sleepers

Example of the track model with rigid semi-sleepers is located in the [{UM_Data}\Samples\Flexible railway track\Single_wheelset](#) directory.

27.5.2.2.3.2. Flexible sleepers

Current UM version does not support flexible sleepers. It will be implemented in the future UM releases.

27.5.3. Simulation

27.5.3.1. Choosing the track model

Track model can be chosen on the **Rail/Wheel | Track | Model and parameters** tab sheet in **Object simulation inspector**, see Figure 27.18.

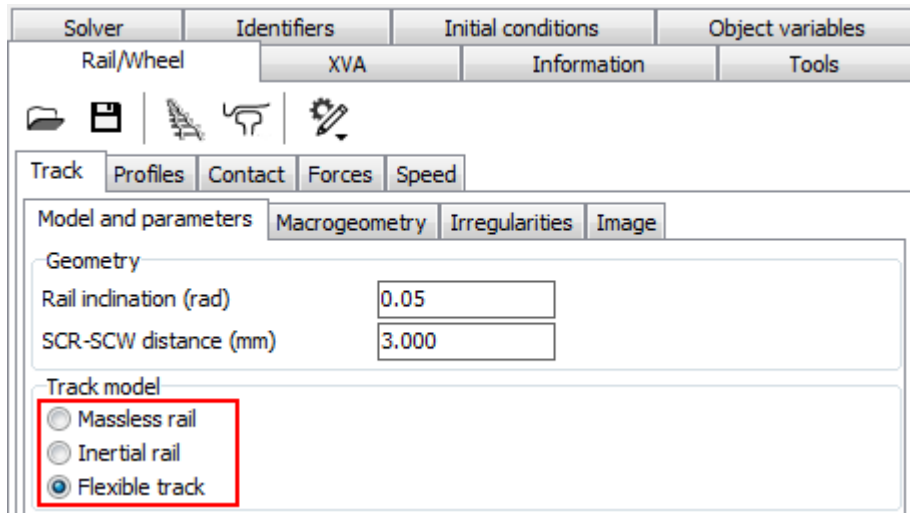

Figure 27.18. Choosing the track model

27.5.3.2. Preparing for simulation

To avoid intensive transition processes in the starting of simulation it is recommended to find the equilibrium position of the system first. As a rule, it is the first step that precedes working with the new UM model with the flexible railway track. To find the equilibrium position set **Object simulation inspector | Rail/Wheel | Speed | Mode of longitudinal motion** to $v=0$ and turn on **Finish test automatically** option, see Figure 27.19. Then run simulation and wait till the simulation finishes automatically.

It might be useful to watch total kinetic energy of the system during the simulation. You can create the **kinetic energy of the system** variable using **Wizard of variables | Variables for groups of bodies** tab, see Figure 27.20. Simulation finishes automatically when the total kinetic energy of the system less than the preset threshold, Figure 27.21.

Simulation of dynamics of flexible railway track is supported by **Park Parallel** solver only. This method is aimed for simulation of models with many d.o.f. using multi-core CPU architecture. Recommended options of **Park Parallel** solver are shown in Figure 27.22.

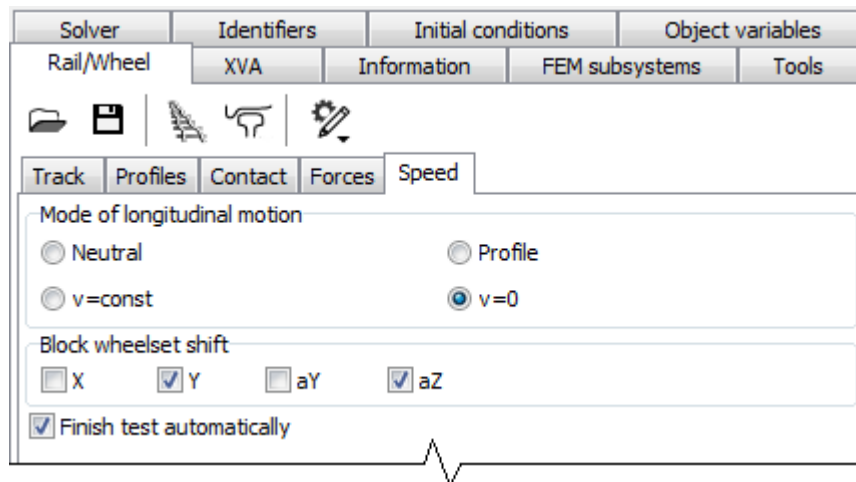

Figure 27.19. Settings for equilibrium test

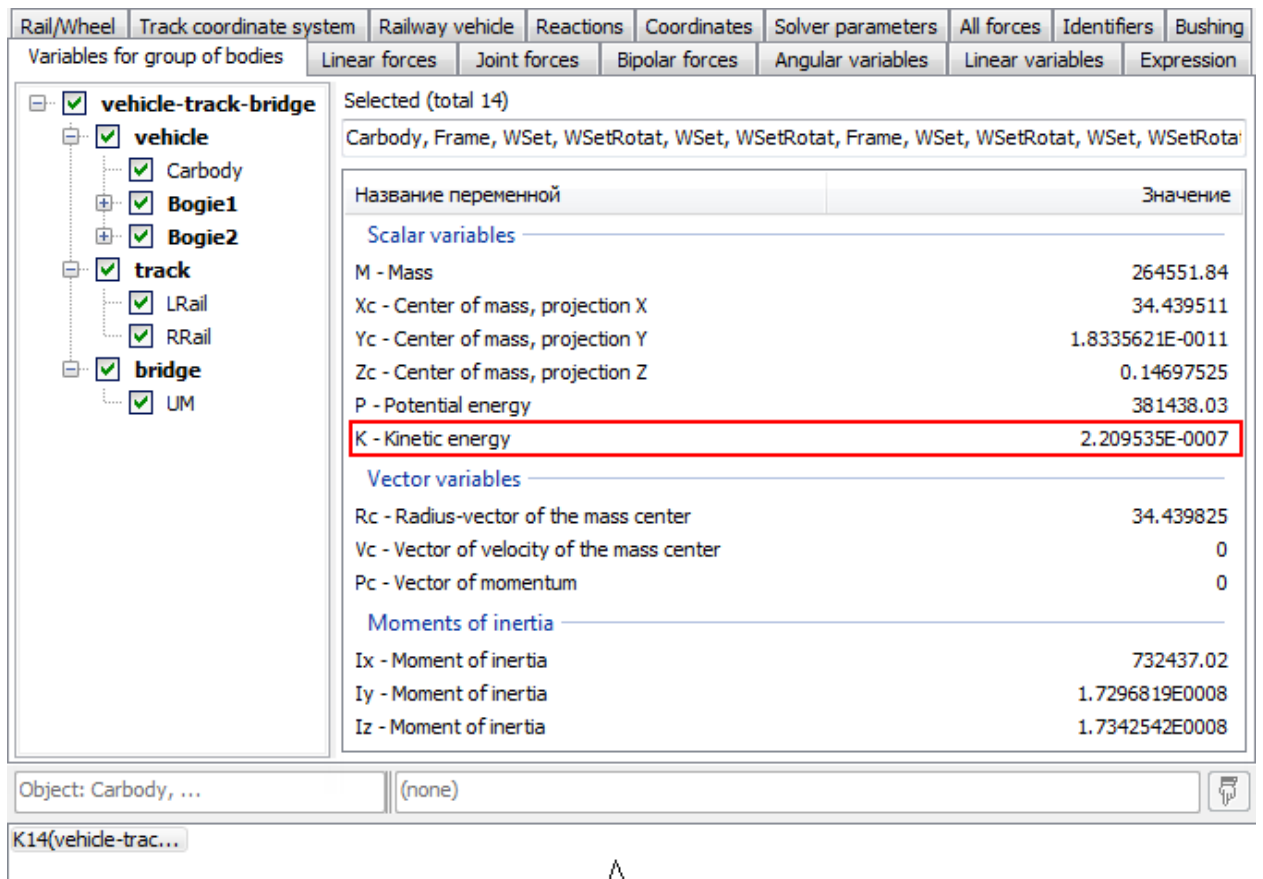

Figure 27.20. Kinetic energy of the system

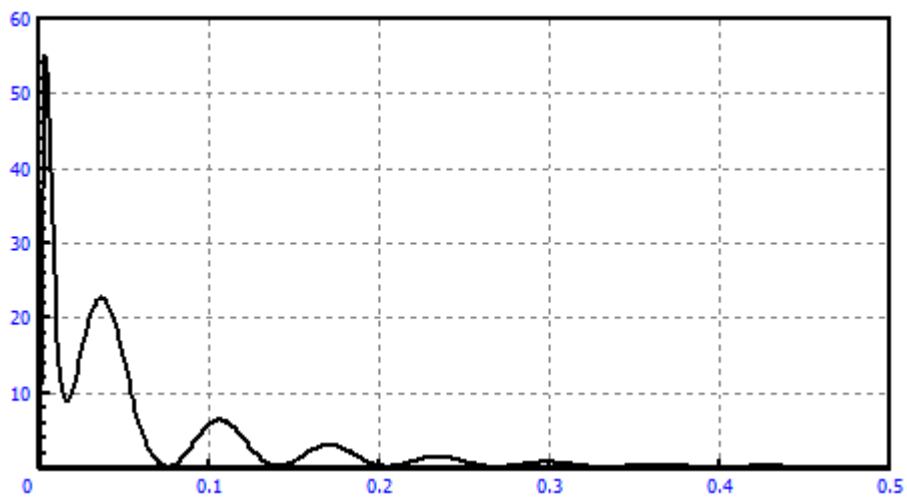

Figure 27.21. Kinetic energy time history during equilibrium test

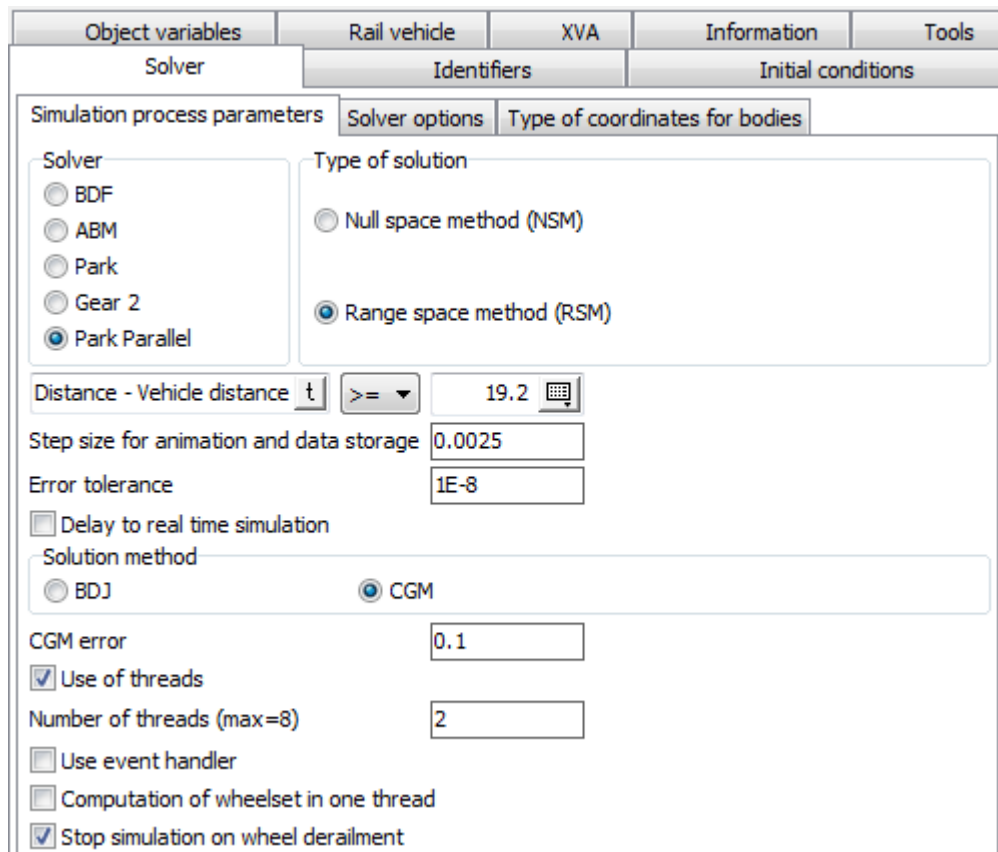

Figure 27.22. Recommended options of **Park Parallel** solver

27.5.3.3. Kinematic characteristics of flexible rails

Variables that correspond to kinematic performances of flexible rails are created with the help of **Wizard of variables** at **Linear variables** tab sheet, see [Chapter 4](#), Sect. "*Linear variables*" of UM user's manual. Creating kinematical variables please note the following comments regarding the body-fixed frame of reference of the flexible rails. X coordinate is the global longitudinal curvilinear coordinate of the considered rail cross-section. Y and Z coordinates should be expressed in central frame of reference of a rail cross-section, see Figure 27.11 and Figure 27.23. For example, to analyze kinematics of the central point on the rail foot of the rail R65 it needs to set Y to 0 and Z to -0.0813 m.

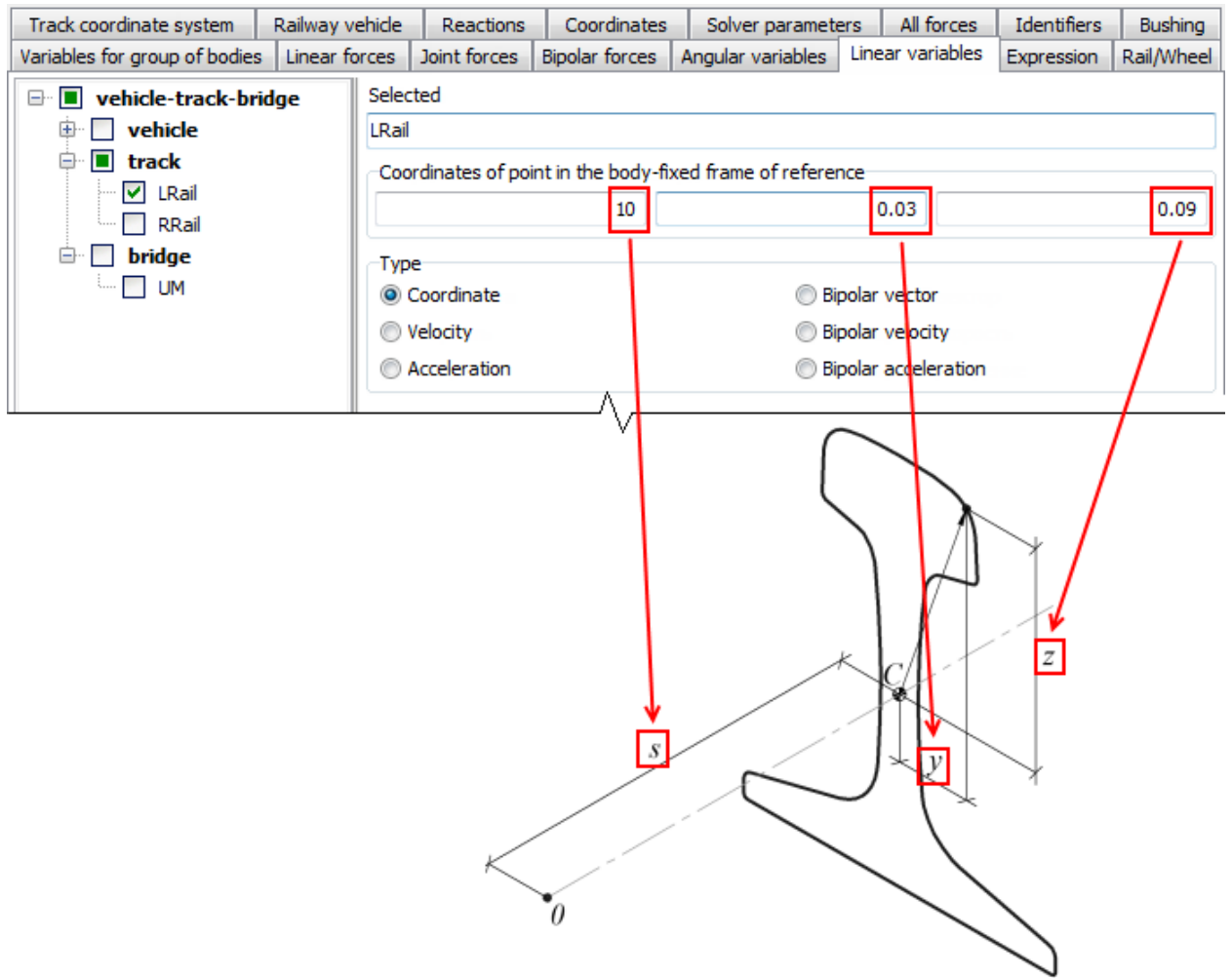

Figure 27.23. Features of flexible rail kinematics

References

- [1] Traian Mazilu, "Green's functions for analysis of dynamic response of wheel/rail to vertical excitation," *Journal of Sound and Vibration*, vol. 306, no. 1-2, pp. 31–58, 2007.
- [2] Riccardo Ferrara, A numerical program for railway vehicle-track-structure dynamic interaction using a modal substructuring approach, PhD thesis, University of Reggio Calabria, Reggio Calabria, 2013.
- [3] Simon Iwnicki, *Handbook of Railway Vehicle Dynamics*. – CRC Press, 2006. – 527 p.
- [4] Ahmed A. Shabana, Khaled E. Zaazaa, Hiroyuki Sugiyama, *Railroad Vehicle Dynamics: A Computational Approach*. – CRC Press, 2008. – 362 p.
- [5] David Thompson, *Railway Noise and Vibration Mechanisms, Modelling and Means of Control*. – Elsevier Science, 2009. – 536 p.
- [6] Popp K., Schiehlen W. (Eds.), *System Dynamics and Long-Term Behaviour of Railway Vehicles, Track and Subgrade*, *Lecture Notes in Applied and Computational Mechanics*, vol. 6. – Springer-Verlag, 2003. – 488 p.
- [7] Knothe K., Grassie S.L., "Modelling of Railway Track and Vehicle-Track Interaction at High Frequencies", *Vehicle System Dynamics*, vol. 22, no. 3-4, pp. 209-262, 1993.
- [8] Traian Mazilu, Green's functions for analysis of dynamic response of wheel/rail to vertical excitation, *Journal of Sound and Vibration*, vol. 306, no. 1-2, pp. 31–58, 2007.
- [9] Knothe K. and Grassie S.L., *Modelling of Railway Track and Vehicle-Track Interaction at High Frequencies*, *Vehicle System Dynamics*, vol. 22, no. 3-4, pp. 209-262, 1993.