



User`s manual



# Dynamic simulation of rail vehicles taking into account flexibility of wheelsets

Tools and methods of Universal Mechanism software for simulation of rail vehicle dynamics taking into account wheel sets flexibility are considered

## Contents

<b>28. DYNAMIC SIMULATION OF RAIL VEHICLES TAKING INTO ACCOUNT FLEXIBILITY OF WHEELSETS .....</b>	<b>3</b>
<b>28.1. GENERAL INFORMATION.....</b>	<b>3</b>
<b>28.2. FIELD OF APPLICATION .....</b>	<b>3</b>
<b>28.3. APPROACHES AND METHODS .....</b>	<b>4</b>
28.3.1. Flexible wheelset kinematics .....	4
28.3.2. Kinematics of wheel profile .....	7
28.3.3. Simulation of rolling .....	9
28.3.3.1. Lagrange approach.....	9
28.3.3.1.1. Calculation of generalized forces .....	10
28.3.3.2. Euler approach.....	12
<b>28.4. CREATING DYNAMIC MODEL OF FLEXIBLE WHEELSET.....</b>	<b>13</b>
28.4.1. Creating finite element model.....	13
<b>28.5. INCLUSION OF FLEXIBLE WHEELSET IN UM INPUT PROGRAM.....</b>	<b>16</b>
28.5.1. Addition of external flexible subsystem .....	16
28.5.2. Introduction of auxiliary coordinate systems .....	21
28.5.3. Editing of model AS4 after introduction of flexible wheelset .....	23
<b>28.6. SIMULATION OF WHEELSET DYNAMICS IN UM SIMUL PROGRAM .....</b>	<b>25</b>
28.6.1. Wizard of variables .....	25
28.6.2. Simulation example .....	32
28.6.2.1. Creating variables .....	33
28.6.2.2. Calculation of equilibrium .....	35
28.6.2.3. Moving in straight track without irregularities .....	40
28.6.2.4. Motion in curvilinear track taking into account irregularities.....	46

## 28. Dynamic simulation of rail vehicles taking into account flexibility of wheelsets

### 28.1. General information

Universal Mechanism software (UM) allows dynamic simulating of rail vehicles taking into account flexibility of wheelsets if the following modules present in the UM configuration: **UM Subsystems**, **UM Loco**, **UM FEM** and **UM Flexible Wheel Set**. This manual describes the rules of creating models of the flexible wheelsets (WS) and analyzing their dynamics.

The following chapters of manual are recommended to study before reading this paper:

- [Chapter 2](#) “Mechanical system as an object for modeling”;
- [Chapter 3](#) “UM Input program”;
- [Chapter 4](#) “UM Simulation program”;
- [Chapter 8](#) “Simulation of rail vehicle dynamics”;
- [Chapter 11](#) “Simulation of dynamics of flexible bodies”.

Besides, it is recommended preliminary study of the documents [gs um](#), [gs um loco](#) and [gs um fem](#) of series “Getting Started” which consist the lessons describing the actions for creating and analyzing dynamic models.

### 28.2. Field of application

Simulation of a wheelset by rigid body interacting with the massless rail is the acceptable approach for analysis of vehicle dynamics in the frequency range up to 50 Hz. However, many studies are impossible without taking into account the flexibility of wheelsets and without detailed models of railway including its inertial and flexible properties. Examples of such researches are analysis of high-frequency (including sound) vibrations of wheelsets and rails, calculating stressed-deformed state and durability of wheelsets, study of corrugation of wheels and rails etc.

Wheel-rail contact force is very stiffness. That is, very small variations of coordinates and velocities of contact areas points lead to significant changes of contact forces. Therefore, simulation of the wheelset in the range above 50 Hz taking into account its flexibility can effect on results of the following kind of studies:

- analysis of the lateral stability of a vehicle;
- calculation of wheel-rail contact forces;
- simulation of wear and changes of wheels and rails profiles;
- analysis of high frequency vibrations including sound.

The following researches can be implemented using flexible wheelset model.

1. Specifying of stress loading and calculation of durability of wheel, wheelset axels and railway components.
2. Dynamic simulation of wheelsets with sliders.
3. Modelling of pass of point switches.
4. Study of wheels and rails corrugation.
5. Study of noises arising with vibrations of wheelsets and rails.

6. Study of bending of wheelset axels and connected with it changes of clearances in track.
7. Researches of bending and torsions of wheelset axels of traction engines under static and dynamic loading and associated with them skews in bearings and gears.
8. Simulation of the tensometric wheelset and analysis its stressed-deformed state.

Theoretically, the frequency range of researches using flexible wheelsets can be widen up to 2,5 kHz.

### 28.3. Approaches and methods

Dynamics of the flexible wheelset are simulated using methods of simulation of the flexible body dynamics, implemented in **UM FEM** ([Chapter 11](#) of **UM User's manual**), and analysis methods of rigid wheelsets, implemented in **UM Loco** ([Chapter 8](#) of the manual).

#### 28.3.1. Flexible wheelset kinematics

In accordance with the underlying approaches of **UM FEM**, the flexible wheelset can move arbitrary as a rigid body, but displacements of its points because of deformations are assumed to be small. Equations of wheelset motion are derived using the finite element method and the modal approach. Flexible node displacements are approximated by a set of the constraint and normal modes calculated in accordance with Craig-Bampton method. Finite element models of wheelsets are created in external FEA programs, the modal analysis is carried out and then required data is imported in **UM**. The algorithms of generation and analysis of dynamic models of flexible bodies as well as the list of FEA programs with which **UM** have the interfaces are given in [Chapter 11](#) of **User's manual**.

The basic ideas and approaches applied for dynamic simulation of flexible WS are shortly explained here. WS kinematics is described using the floating frame of reference method. (Figure 28.1.).

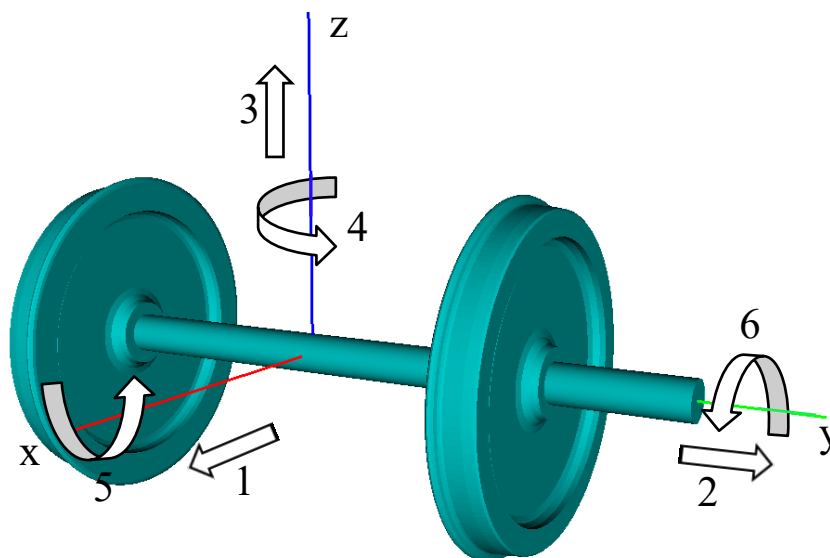

Figure 28.1. Wheelset coordinate system and numeration of degrees of freedom defining it position and orientation

Position of an arbitrary point  $K$  relative to the global coordinate system 0 (SC0) is the sum of the radius-vector to the origin of the local SC1 and the radius-vector of the point relative to SC1 (Figure 28.2):

$$\mathbf{r}_k^{(0)} = \mathbf{r}_1^{(0)} + \mathbf{A}_{01}\mathbf{p}_k^{(1)},$$

where  $\mathbf{A}_{01}$  is the rotation matrix of SC1 relative to SC0, the vectors are presented in the coordinate systems marked by upper indices in brackets.

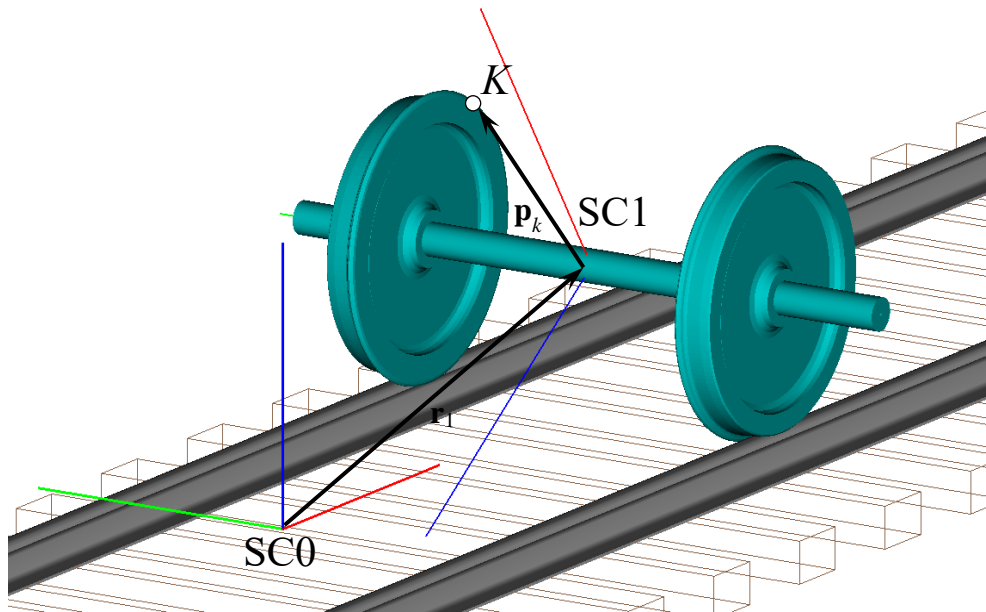

Figure 28.2. Specifying of position of wheelset point  $K$  using local SC1

Radius-vector  $\mathbf{p}_k$  can be presented as the sum (Figure 28.3)

$$\mathbf{p}_k = \boldsymbol{\rho}_k + \mathbf{d}_k,$$

where  $\boldsymbol{\rho}_k$  is the radius-vector of point  $K$ , it is constant relative to SC1 in the undeformed WS state,  $\mathbf{d}_k$  is the displacement of the point  $K$  due to deformation.

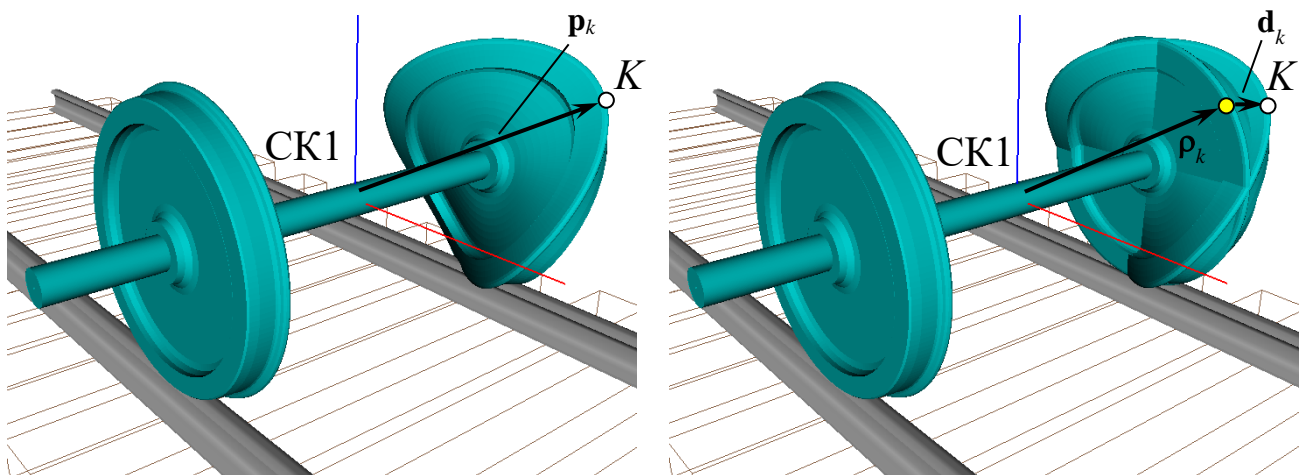

Figure 28.3. Definition of position of an arbitrary point  $K$  relative to the local SC of wheelset

Flexible displacements of wheelset points are calculated applying the finite element method and modal approach. Node displacements in the local reference frame are the product of the modal matrix and the matrix-column of modal coordinates

$$\mathbf{x} = \sum_{j=1}^H \mathbf{h}_j w_j = \mathbf{H} \mathbf{w}$$

where  $\mathbf{x}$  is the  $N \times 1$  matrix-column of nodal coordinates,  $N$  is the number of degrees of freedom of the FE model,  $\mathbf{h}_j$  is the  $j$ -th mode of the flexible wheelset,  $w_j$  is the  $j$ -th modal coordinate,  $\mathbf{H}$  is the number of used modes,  $\mathbf{H}$  is the  $N \times H$  modal matrix.

Thus, the replacement and considerable decreasing the number of coordinates are carried out. The nodal coordinates, which number  $N$  can be several hundreds of thousand, are substituted by modal coordinates which number  $H$  is relative small. Usually, it does not exceed one hundred.

If a node is placed in point  $K$ , its flexible displacements can be presented by the product

$$\mathbf{d}_k = \mathbf{H}_k \mathbf{w}$$

where  $\mathbf{H}_k$  is the part of the modal matrix corresponding to node  $K$ .

The flexible modes  $\mathbf{h}_j$  are calculated in accordance with the Craig-Bampton method. At the beginning, interface nodes are selected in joint points and in points of force elements attachment. Then the constraint static modes from unit displacements in the interface nodes and the fixed-interface normal modes are calculated. The number of used normal modes is chosen by a researcher depending on a necessary frequency range.

The examples of constraint and fixed-interface modes of WS are shown in Figure 28.4. Two interface nodes are selected in the axle ends.

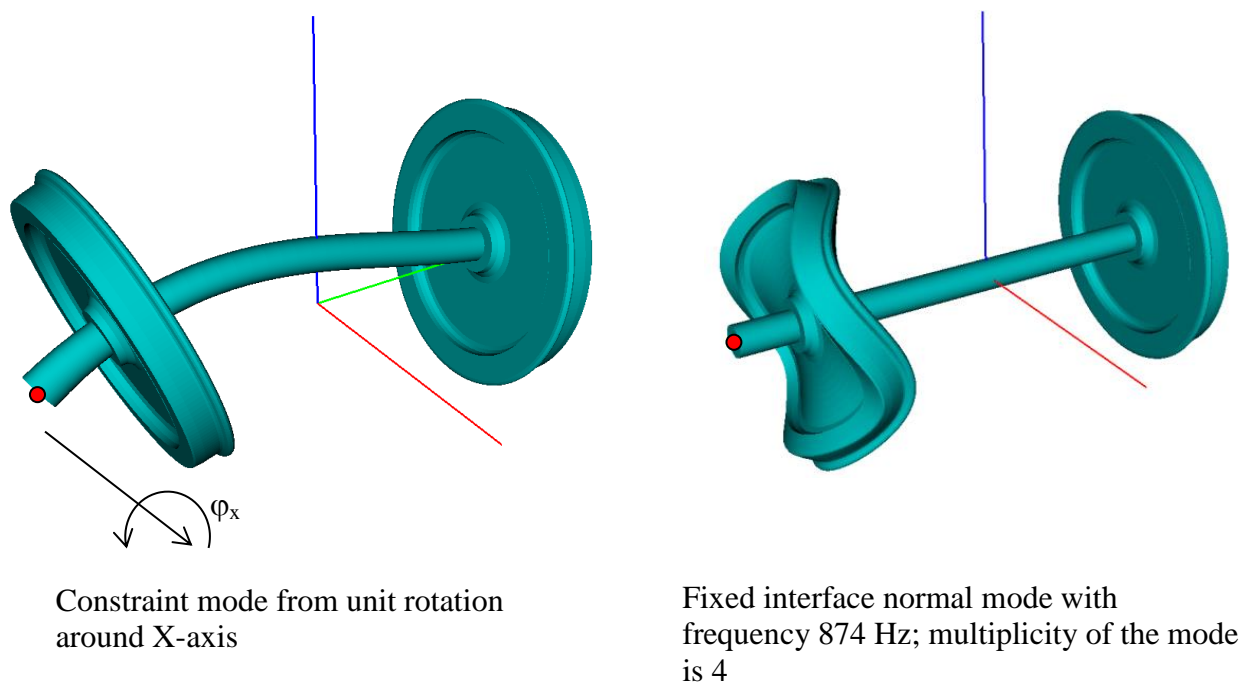

Figure 28.4. Examples of wheelset Craig-Bampton component modes

In order to exclude rigid body motion relative to the local reference frame, component modes are transformed using solution of generalized eigenvalue problem with the reduced matrices of the wheelset.

Usually, connecting points of force elements and joints placed in the nodes of finite element mesh. In this case, Craig-Bampton method leads to accurate enough results using relative small number of the modes.

### 28.3.2. Kinematics of wheel profile

A wheel-rail contact force is the moving loading. That is, the application point is changed relative to the local coordinate system during vehicle motion; it does not coincide with any node of FE mesh. This is one of the main problems for simulation of the flexible wheelset.

In additions, a way of description of wheel profile kinematics should be suggested taking into account the wheelset flexibility. For rigid wheels, a profile is described with the help of the curve editor in the coordinate system with the origin on the running circle. (see items 8.1.3.5 “Wheelset geometry” and 8.5.1.1 “Creation of wheel and rail profiles” of [Chapter 8](#) of User’s manual). The profile is undeformed during wheelset motion. Position of any point relative to global SC0 is defined by position and orientation of the local SC of the wheelset and by radius-vector of point *K* on running circle relative to the local SC. The coordinates defining position and orientation of profile relative to the rail SC are shown in Figure 28.5. This figure is the copy of figure 8.88. It is presented here for handy study of this chapter.

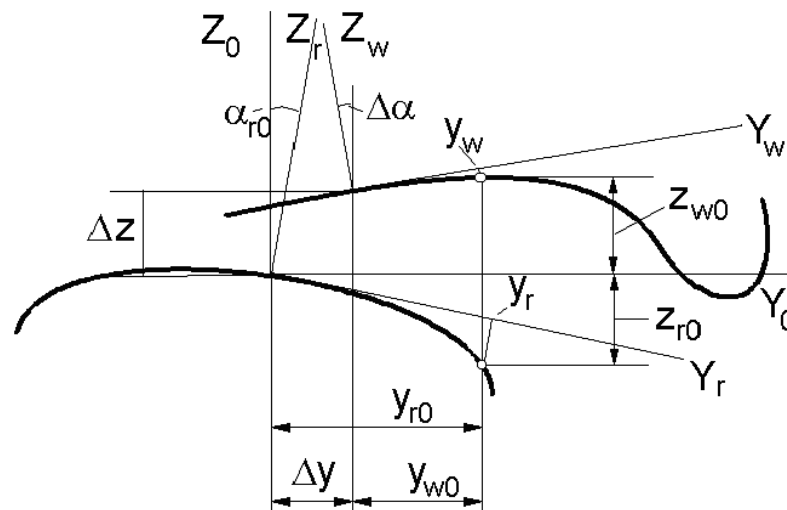

Figure 28.5. Relative position of wheel and rail profiles

Similar to the rigid wheelset, the profile of the flexible wheelset is also assumed to be non-deformable but its position and orientation are computed taking into account displacements of nodes on wheel rolling surface applying ordinary least squares.

Let us shortly consider this method. The wheelset FE model is created by rotation of a planar half-section mesh around the wheelset axis with angle the step  $\Delta\alpha$ . This mesh must contain some nodes locating exactly on the wheel profile. Thus, there are nodes belonging to the wheel profile in each *i*-th section turned on the angle  $i\Delta\alpha$ . Position and orientation of the wheel profile in contact with the rail are calculated taking into account flexible displacements of the intersection points of profile with the mesh lines between two sections (Figure 28.6). The point displacements are computed by interpolation of the corresponding values of the neighboring nodes.

At the beginning, let us suppose that the profile contacting with the rail passes through nodes of the mesh and describe the profile kinematics (Figure 28.6).

The interpolation when the profile is placed between mesh lines will be considered in the next item.

The following designations are introduced for the description of the calculation algorithm of current profile position:

$\rho_{i0}$  is the position of  $i$ -th node on profile in the flexible WS model without deformations;

$\delta\mathbf{r}_i$  is the flexible displacement of  $i$ -th node;

$\delta X, \delta Z(\delta\mathbf{R})$  is the required displacement of SC of wheel profile;

$\delta\alpha$  is the required rotation angle of SC of wheel profile.

The nodes positions can be presented taking into account flexible displacements as the sum:

$$\rho_i = \rho_{i0} + \delta\mathbf{r}_i .$$

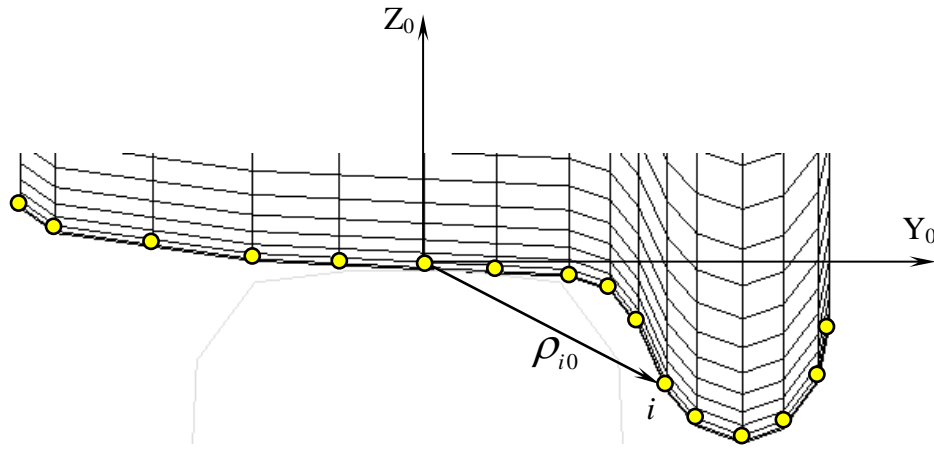

Figure 28.6. Position of  $i$ -th profile node in the SC wheel profile

From other side, the nodes positions can be written taking into account changes the position and orientation of the profile as the following:

$$\mathbf{R}_i = \rho_{i0} + \delta\mathbf{R} - \tilde{\rho}_{i0} \mathbf{e}_x \delta\alpha ,$$

where  $\tilde{\rho}_{i0}$  is the skew-symmetric tensor, created on the vector  $\rho_{i0}$ ,  $\mathbf{e}_x$  is the unit vector along X-axis, perpendicular to the picture plane (the direction of vehicle motion).

Let us define the total residual by the following expression:

$$\varepsilon(\delta\mathbf{R}, \delta\alpha) = \sum (\mathbf{R}_i^T - \rho_i^T) (\mathbf{R}_i - \rho_i) .$$

Then, extremum conditions using in the least squares method can be presented by the following equations:

$$\frac{\partial \varepsilon}{\partial \mathbf{R}} = 2 \sum (\delta\mathbf{R} - \tilde{\rho}_{i0} \mathbf{e}_x \delta\alpha - \delta\mathbf{r}_i) = 0 ,$$

$$\frac{\partial \varepsilon}{\partial \alpha} = 2 \mathbf{e}_x^T \sum \tilde{\rho}_{i0} (\delta\mathbf{R} - \tilde{\rho}_{i0} \mathbf{e}_x \delta\alpha - \delta\mathbf{r}_i) = 0 .$$

These equations are transformed to following form handy to calculation of required values  $\delta\mathbf{R}, \delta\alpha$ :

$$(-n \|\boldsymbol{\rho}\|^2 + \sum \|\rho_{i0}\|^2) \delta\alpha + \mathbf{e}_x^T (n \tilde{\boldsymbol{\rho}} \delta\mathbf{r} - \sum \tilde{\rho}_{i0} \delta\mathbf{r}_i) = 0 ,$$

$$\delta \mathbf{R} = \frac{1}{n} (\sum \delta \mathbf{r}_i + (\sum \tilde{\rho}_{i0}) \mathbf{e}_x \delta \alpha) = \delta \mathbf{r} + \tilde{\rho} \mathbf{e}_x \delta \alpha,$$

where  $n$  is the number of nodes on the wheel profile.

### 28.3.3. Simulation of rolling

The wheel profiles contacting with the rail during vehicle motion are placed between the lines of the finite element mesh. The calculation algorithm of profile kinematics should be modified taking into account this fact. Besides, a method of calculating generalized force from a force applied in an arbitrary point on the wheel surface should be proposed. In **UM**, two approaches to solution of the problem are implemented. They are conventionally called Lagrange and Euler approaches.

Speaking by simple words, in accordance with Lagrange approach a researcher observes the points of an object moving in the space. It is usual approach for multibody system dynamics. It is applied for derivation of equation of motion in **UM**.

In accordance with Euler approach, the points of space are observed. That is, the equations of motion describe behavior of the points of space occupied by the simulated object. In Eulerian coordinates, the flexible displacements are described by Navier-Stokes equations of motion non-typical for multibody system dynamics. The finite element mesh not rotate in Eulerian coordinates. If in the initial time a wheel are oriented so, that line of the contacting profile pass through nodes, this small set of nodes will define the profile kinematics to the end of numerical integration of equation. The forces from contact interactions with the rail are applied to the nodes of this set as well. Thus, it can be suppose that use of Euler approach allows increasing the simulation effectiveness and makes some researches handier.

In **UM**, Euler approach is not used as it is described above. That is, Navier-Stokes equations of motion are not used for description of the flexible displacements. Instead of this, the algorithm simulating Euler approach is developed and implemented. It is executed on the stage of numerical integration of equations of motion. Non rotating finite element mesh is the main result of application of this algorithm. Therefore, fixed set of nodes in a single wheelset section can be used for calculation of the profile kinematics and the generalized forces from contact interactions.

Let us describe the proposed approaches in more detail.

#### 28.3.3.1. Lagrange approach

In arbitrary instant, the wheel profile contacting with the rail is placed between nodes of the finite element mesh (Figure 28.7).

In this case, profile kinematics is computed using characteristics of the corresponding points. Let us consider the cylindrical coordinate system  $(\rho, \varphi, z)$ . The axis of this SC coincides with the rotation axis of the wheelset.

The wheelset FE model is created by rotation of a planar half-section mesh around the wheelset axis with the angle step  $\Delta\alpha$ . This mesh must contain some nodes locating exactly on the wheel profile. Thus, there are nodes belonging to the wheel profile in each  $i$ -th section turned on

the angle  $i\Delta\alpha$ . The rules of making finite element model of a wheelset are given in section 2 of this manual.

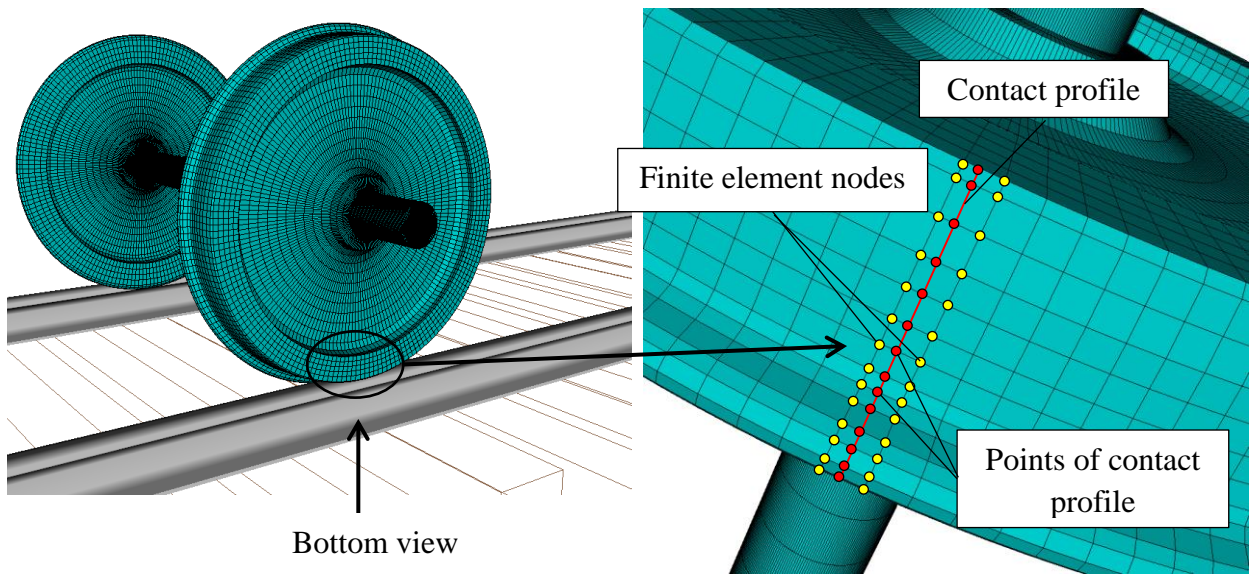

Figure 28.7. On description of position and orientation of flexible WS profile

Then, after rotation of the wheelset on angle  $\varphi_p$ , the flexible displacements of each of  $n$  points defining profile kinematics are calculated using two nearest nodes with the equal cylindrical coordinates  $\rho$  and  $z$  (Figure 28.8):

$$\delta \mathbf{r}_i = a \delta \mathbf{r}_{i,j} + b \delta \mathbf{r}_{i,j+1}, \text{ where } a = \frac{\varphi_{j+1} - \varphi_p}{\varphi_{j+1} - \varphi_j}, \quad b = \frac{\varphi_p - \varphi_j}{\varphi_{j+1} - \varphi_j}, \quad i=1..n, \quad j=1..m, \quad m \text{ is the section}$$

number of the FE model.

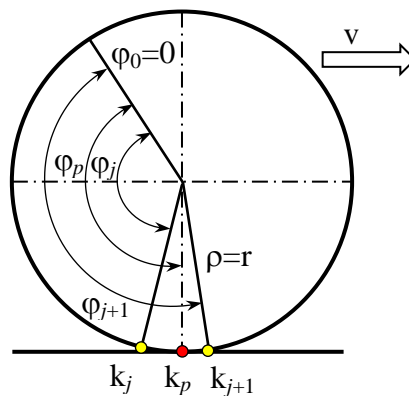

Figure 28.8. On calculation of positions and velocities of the contact profile in the cylindrical SC

Flexible velocity of the points is computed similarly.

### 28.3.3.1.1. Calculation of generalized forces

The WS model consists of the eight-node hexahedral finite elements. Let us consider the basic ideas underlying the calculation algorithm for generalized forces from loads applied in an arbitrary point on a FE face. That is, a way of the load distribution between the nodes of the FE

face should be applied. After that, the generalized forces are computed using the algorithms for immovable forces developed before in **UM FEM**.

In **UM**, two ways of calculation of nodal forces can be applied: 1) simplified way taking into account only geometry of polygon on which the force acts and 2) distribution of applied force using form functions of the finite element.

If the simplified way is used, the external force is distributed between the face nodes in two stages inversely to the distances from the force to the face nodes. (Figure 28.9).

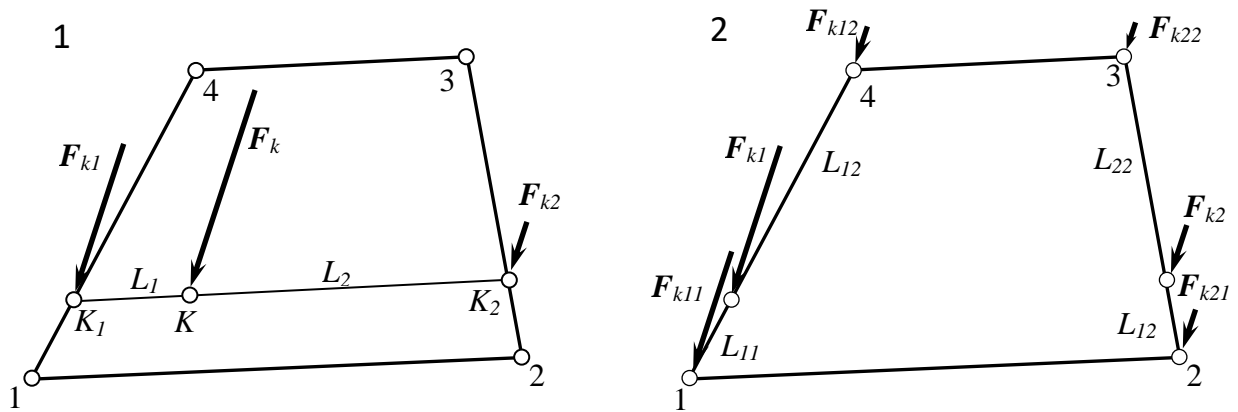

Figure 28.9. Simplified way of calculation of node forces

Let us consider the isoparametric form of the hexahedral finite element for the description of algorithm of nodal forces calculation. The auxiliary system of dimensionless coordinates  $\xi, \eta, \zeta$  with the origin in the FE center is introduced (Figure 28.10).

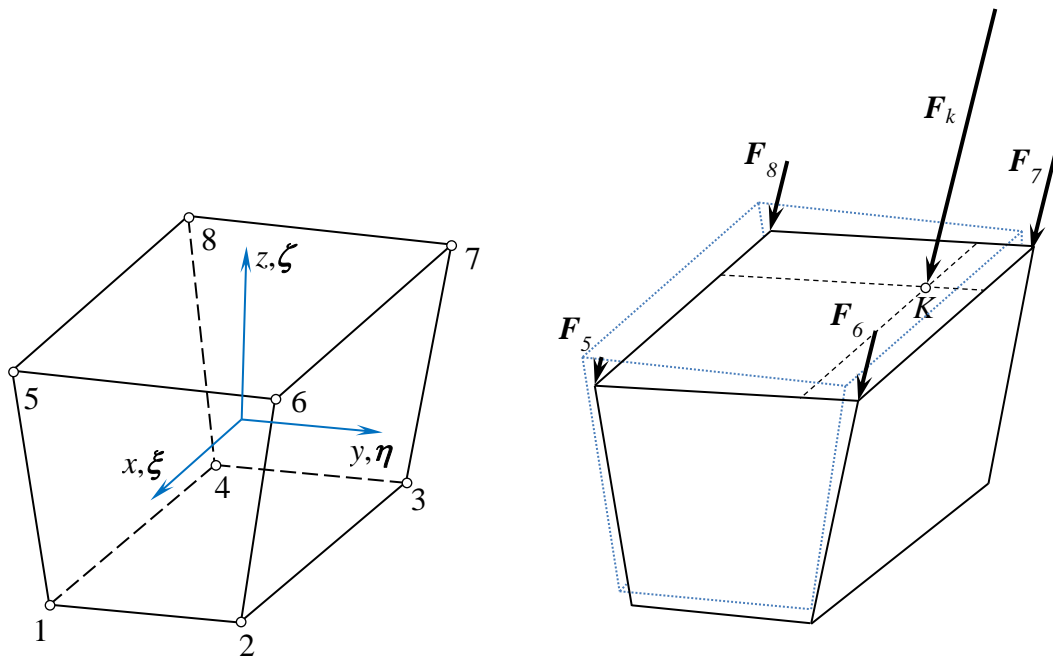

Figure 28.10. To calculation of nodal forces using form functions of the finite element

Values of the dimensionless coordinates in the nodes are equal to  $\pm 1$ . The displacements of points of the finite element along  $x, y$  and  $z$  axis are correspondingly designated as  $u, v, w$ . Then, displacement fields are defined by the following expressions:

$$u(\xi, \eta, \zeta) = \mathbf{N}(\xi, \eta, \zeta) \mathbf{u}_e,$$

$$v(\xi, \eta, \zeta) = \mathbf{N}(\xi, \eta, \zeta) \mathbf{v}_e,$$

$$w(\xi, \eta, \zeta) = \mathbf{N}(\xi, \eta, \zeta) \mathbf{w}_e,$$

where  $\mathbf{u}_e = [u_1, \dots, u_8]^T$ ,  $\mathbf{v}_e = [v_1, \dots, v_8]^T$ ,  $\mathbf{w}_e = [w_1, \dots, w_8]^T$ ,  $\mathbf{N} = [N_1, \dots, N_8]$ ,

$$N_i = 1/8 \cdot (1 + \xi \xi_i)(1 + \eta \eta_i)(1 + \zeta \zeta_i), \quad i=1..8, \text{ for example,}$$

$$N_3 = 1/8 \cdot (1 - \xi)(1 + \eta)(1 - \zeta).$$

The nodal forces from the force applied in an arbitrary point  $K$  are calculated using the following relations:

$$\mathbf{F}_{ex} = \mathbf{N}^T(\xi_K, \eta_K, \zeta_K) F_{kx},$$

$$\mathbf{F}_{ey} = \mathbf{N}^T(\xi_K, \eta_K, \zeta_K) F_{ky},$$

$$\mathbf{F}_{ez} = \mathbf{N}^T(\xi_K, \eta_K, \zeta_K) F_{kz},$$

where  $\mathbf{F}_{ex} = [F_{x1}, \dots, F_{x8}]^T$ ,  $\mathbf{F}_{ey} = [F_{y1}, \dots, F_{y8}]^T$ ,  $\mathbf{F}_{ez} = [F_{z1}, \dots, F_{z8}]^T$ ,  $\xi_K, \eta_K, \zeta_K$  are the dimensionless coordinates of point  $K$ ,  $F_{kx}, F_{ky}, F_{kz}$  are the projections of force  $\mathbf{F}_k$ . The forces applied in the nodes 1–4 are not shown in Figure 28.10. They are very small but, strictly speaking, not equal to zero in general case. The algorithms of calculation of the dimensionless coordinates of point  $K$  using its Cartesian coordinates are implemented in **UM**.

### 28.3.3.2. Euler approach

In this section, the basic ideas of the algorithm simulating Euler approach on the stage of numerical integration of the equations are explained. The following designates are introduced (Figure 28.11):

$\Delta \mathbf{r}_k$  is the flexible displacement in the node with index  $k$  on the previous integration step,

$\Delta \mathbf{r}_{k'}$  is the flexible displacement in the point, occupied by node  $k$  before current integration step, after rotation of the wheelset on angle  $d\alpha$ ,

$d\alpha = \varepsilon \Delta \alpha$ , where  $\Delta \alpha$  is the angle step of FE mesh,  $\varepsilon \in [0, \varepsilon_{\max}]$ .

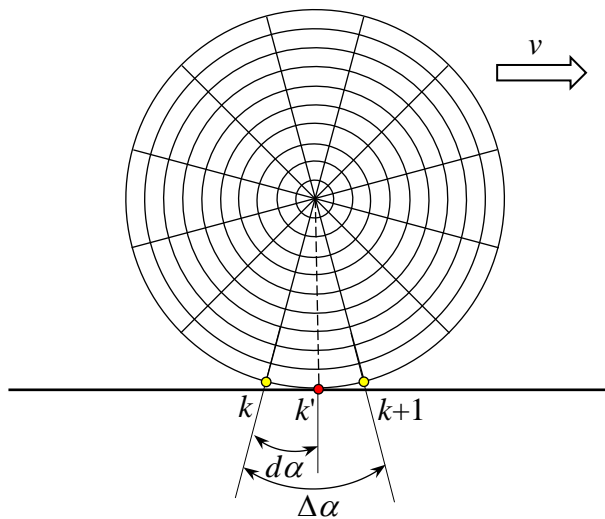

Figure 28.11. To description of Euler approach

The basic idea of the proposed approach is that the flexible displacement of point  $k'$  and its flexible velocity are calculated approximately using kinematic characteristics of nodes  $k$ ,  $k+1$  and possibly  $k+2$ . The nodes  $k$ ,  $k+1$  and point  $k'$  lie on the single circle. More precisely, their coordinates  $\rho$  and  $z$  are equal in the cylindrical coordinate system if deformations are absent. The node  $k+1$  are called "next node" relative to node  $k$ , that is the next node will fill place of previous node after rotation of the wheelset on angle  $\Delta\alpha$ .

These calculations are carried out for all nodes of the FE model, after that the mesh is "turned" backwards on angle  $-\Delta\alpha$  and calculated flexible displacements and velocities are set for the corresponding nodes. Besides, the transformations of equations providing their correctness on every integration step are carried out.

The linear and quadratic interpolations of the flexible displacements are implemented:

$$\Delta\mathbf{r}_{k'} = a\Delta\mathbf{r}_k + b\Delta\mathbf{A}\Delta\mathbf{r}_{k+1} + c\Delta\mathbf{A}^2\Delta\mathbf{r}_{k+2},$$

where  $\Delta\mathbf{A} = \mathbf{A}_y(\Delta\alpha)$  is the orientation matrix corresponding to the rotation around wheelset axle on angle  $\Delta\alpha$ ,  $\Delta\mathbf{r}_{k+1}$ ,  $\Delta\mathbf{r}_{k+2}$  are the flexible displacements of the next nodes.

For the linear interpolation, the following expressions are correct:

$$\varepsilon_{\max} = 1, \quad a = 1 - \varepsilon, \quad b = \varepsilon, \quad c = 0;$$

for quadratic interpolation:

$$\varepsilon_{\max} = 2, \quad a = 1 - 1.5\varepsilon + 0.5\varepsilon^2, \quad b = 2\varepsilon - \varepsilon^2, \quad c = -0.5\varepsilon + 0.5\varepsilon^2.$$

Note, the coefficients in the defined ranges do not exceed 1 for both cases; it is important for stability of the numerical integration methods.

The proposed approaches and methods for dynamic simulation of flexible wheelsets are implemented in program module **UM Flexible Wheel Set**. In the next sections of this chapter, creation of models and their analysis with the help of this program module are sequentially considered.

## 28.4. Creating dynamic model of flexible wheelset

The algorithm of making dynamic model of a flexible body is described in [Chapter 11](#) of UM User's manual. Data preparation for the flexible wheelset corresponds completely to this algorithm. The several additional requirements associated with wheelset construction are described in the following section.

### 28.4.1. Creating finite element model

A finite element model of a flexible wheelset must be created via *rotation of half of its cross-section around Y axis with a constant angle step* (Figure 28.12). If this requirement is not met, the model is considered as incorrect. The corresponding message is shown after addition of the flexible subsystem (see p. 28.5.1).

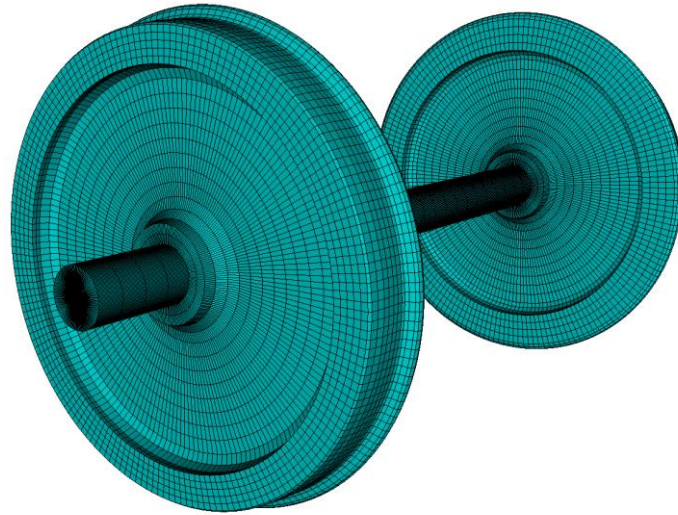

Figure 28.12. Finite element model of the flexible wheelset of railcar AS4

Let us consider the main stages of creating the model. At the beginning, the geometry of half of WS cross-section is described in an external FEA program and planar FE mesh is generated (Figure 28.13). The main attention should be given to description of the wheel profile.

A node must be in point K defining running circle of the wheel. Its position is specified by the radius of the running circle  $r$  and by the semibase of the wheelset  $L/2$  (see item 8.1.3.5 “Wheelset geometry” of chapter 8 of UM User’s manual).

Point K coincides with the origin of coordinate system intended for description of the wheel profile with the help of the curve editor of UM. This profile is used in program **UMSimul.exe** for simulation of the wheelset dynamics.

If the origin of profile SC is superposed with point K, the nodes of boundary of the cross-section must be placed on the profile. In the last resort, they must lie near to profile line. That is, distances between the boundary nodes and the profile must be small after superpose of the profile SC origin with point K.

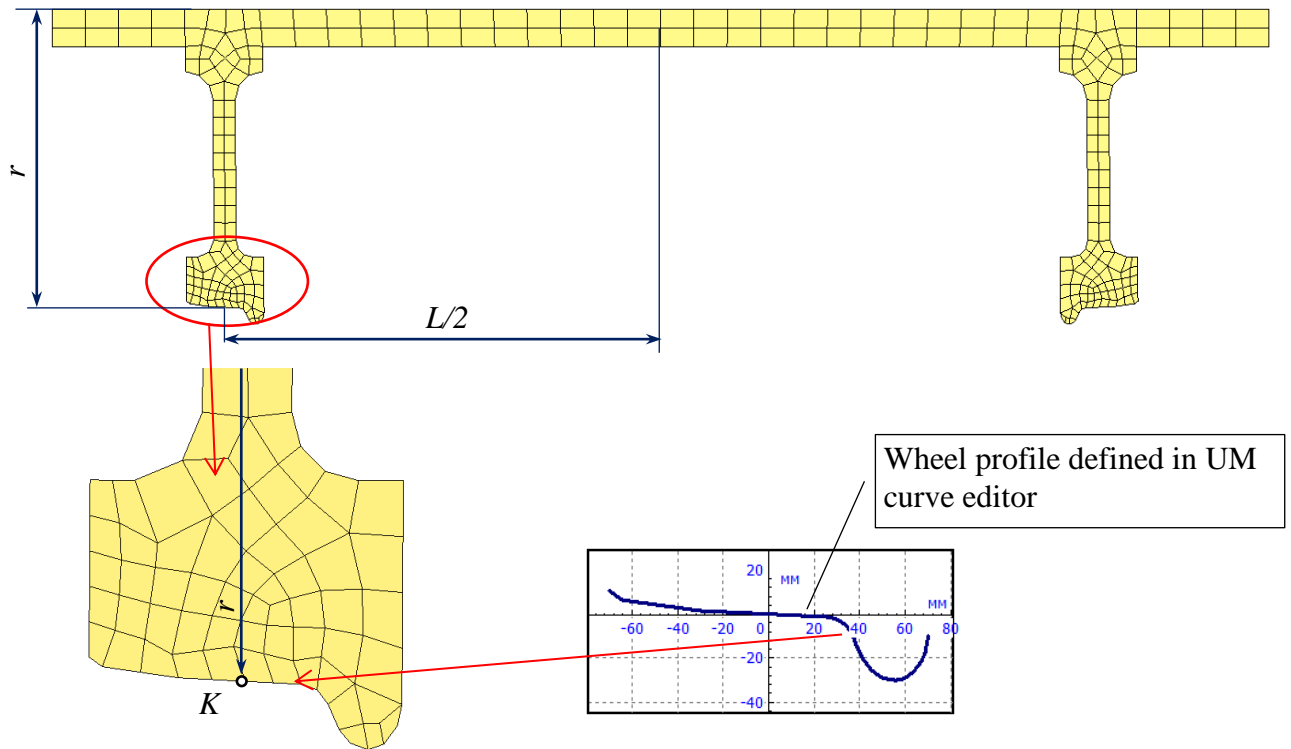

Figure 28.13. Finite element mesh of the half of cross-section of the wheelset

A 3D FE model of the flexible wheelset is created via rotation of the planar FE mesh around wheelset axle on 360 degrees with some angle step. The selected angle step should ensure smoothness of the rolling surface. For example, the FE model presented in Figure 28.12 is created with angle step  $2^\circ$ .

In ANSYS, the described actions are implemented after creating the planar mesh by the following APDL commands:

*ESIZE, SIZE, NDIV*

(the menu item is *Main Menu>Preprocessor>Meshing>Size Cntrls>ManualSize>Global>Size*)

*VROTAT, NA1, NA2, NA3, NA4, NA5, NA6, PAX1, PAX2, ARC, NSEG*

(the menu item is *Main Menu>Preprocessor>Modeling>Operate>Extrude>Areas>About Axis*)

The detailed descriptions of these commands can be found in ANSYS help system.

Before executing *VROTAT* command, type *SOLID185* should be added in the list of finite element types (the menu item *Main Menu>Preprocessor>Element type>Add/Edit/Delete*). The plane finite elements should be deleted after generating the 3D model.

Creating the FE model of the wheelset using other FEA programs is carried out by similar actions. Its descriptions are presented in the corresponding help systems.

The vertical cross-section should be in the FE model when rotation angle equal to zero (Figure 28.14). It is one more requirement that is satisfied automatically if rotating cross-section is defined in the plane XZ.

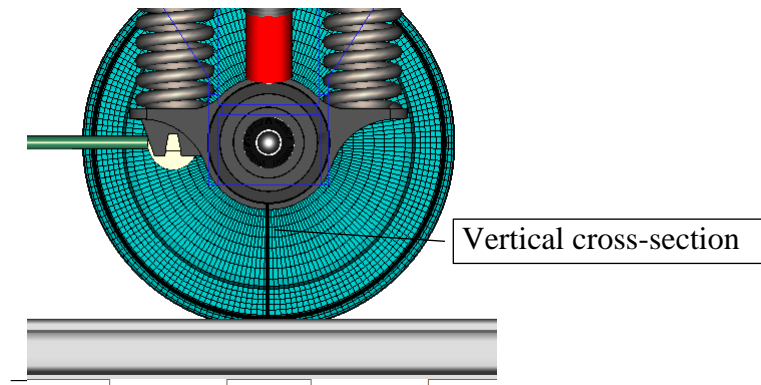

Figure 28.14. Vertical cross-section in the finite element model of the wheelset when rotation angle around the axle is zero

## 28.5. Inclusion of flexible wheelset in UM Input program

In this section, inclusion of flexible wheelset to a model of rail vehicle is considered. The general rules are presented below using the model of railcar AS4 which is included in the samples list supplied with **UM**. Creating this model is described in the manual “UM Loco. Getting started”, file [gs um loco](#).

Let us change the front rigid wheelset by the flexible one (Figure 28.15).

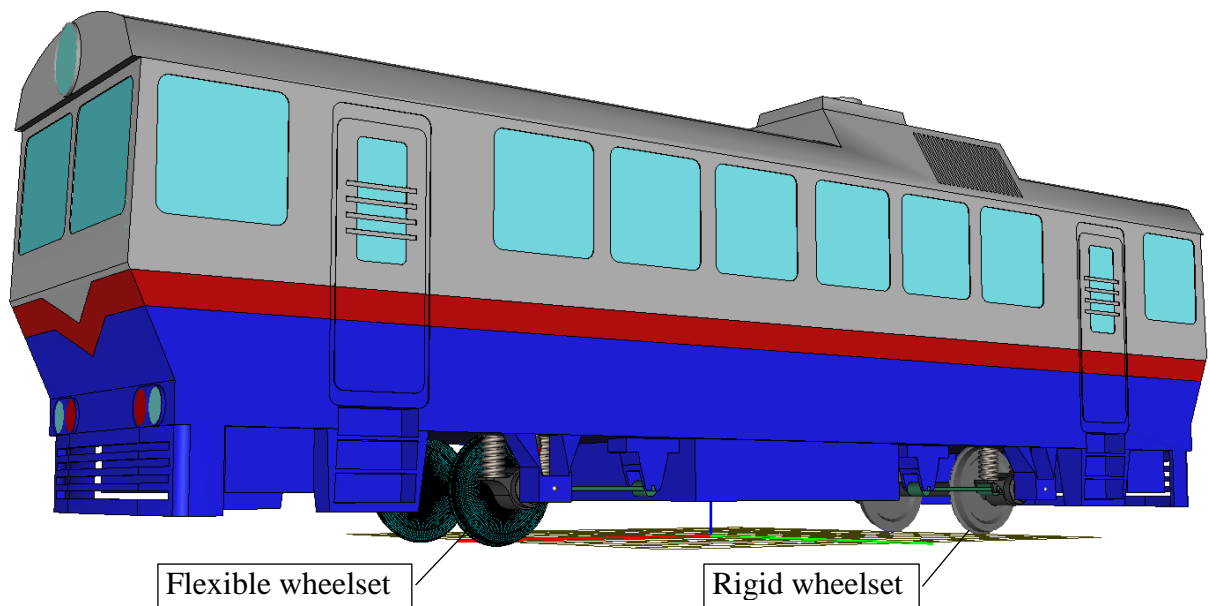



Figure 28.15. Model of railcar AS4 with the flexible front wheelset

### 28.5.1. Addition of external flexible subsystem

At the beginning, let us consider addition of the flexible wheelset when a new model of a rail vehicle is created. The following actions should be carried out (Figure 28.16):

- to select **Subsystems** in the tree of model elements;
- to add a new subsystem by button .
- to select the subsystem type **wWheelset**;
- to select **Flexible wheelset** in radio group **Type of wheelset**;

– to push **Edit subsystem** button and to describe a model of a flexible wheelset in the new opened window of **Object constructor** (Figure 28.17).

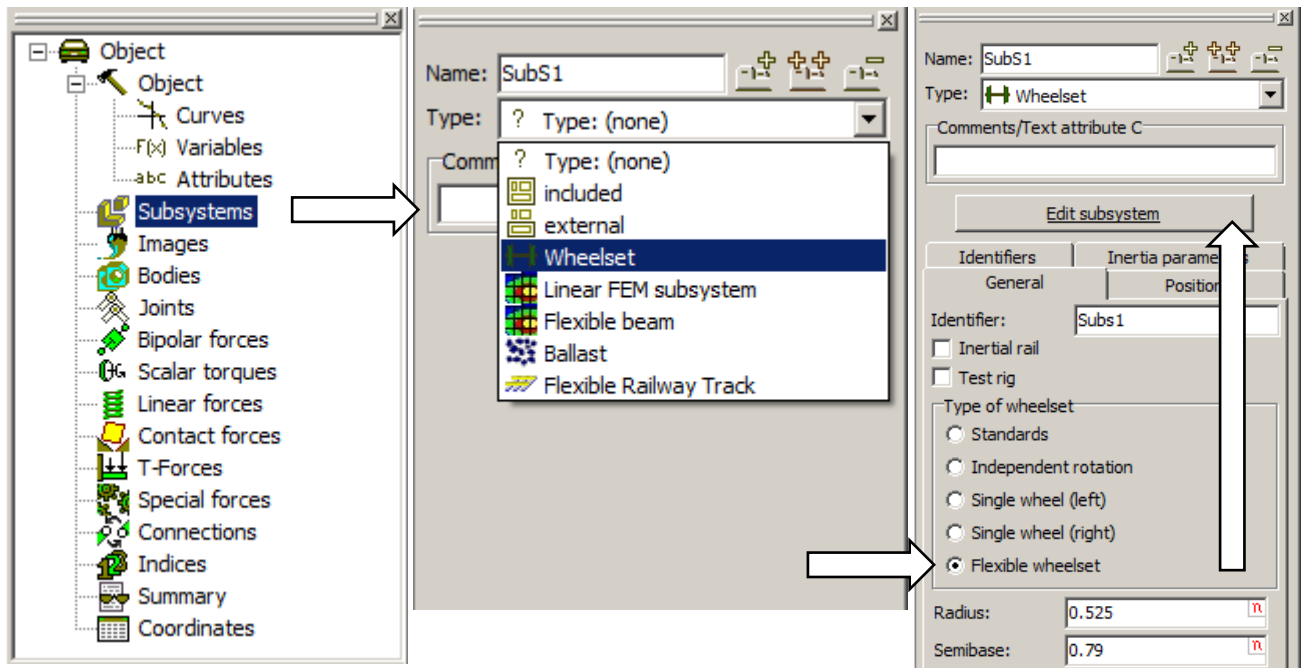

Figure 28.16. Addition of the flexible wheelset

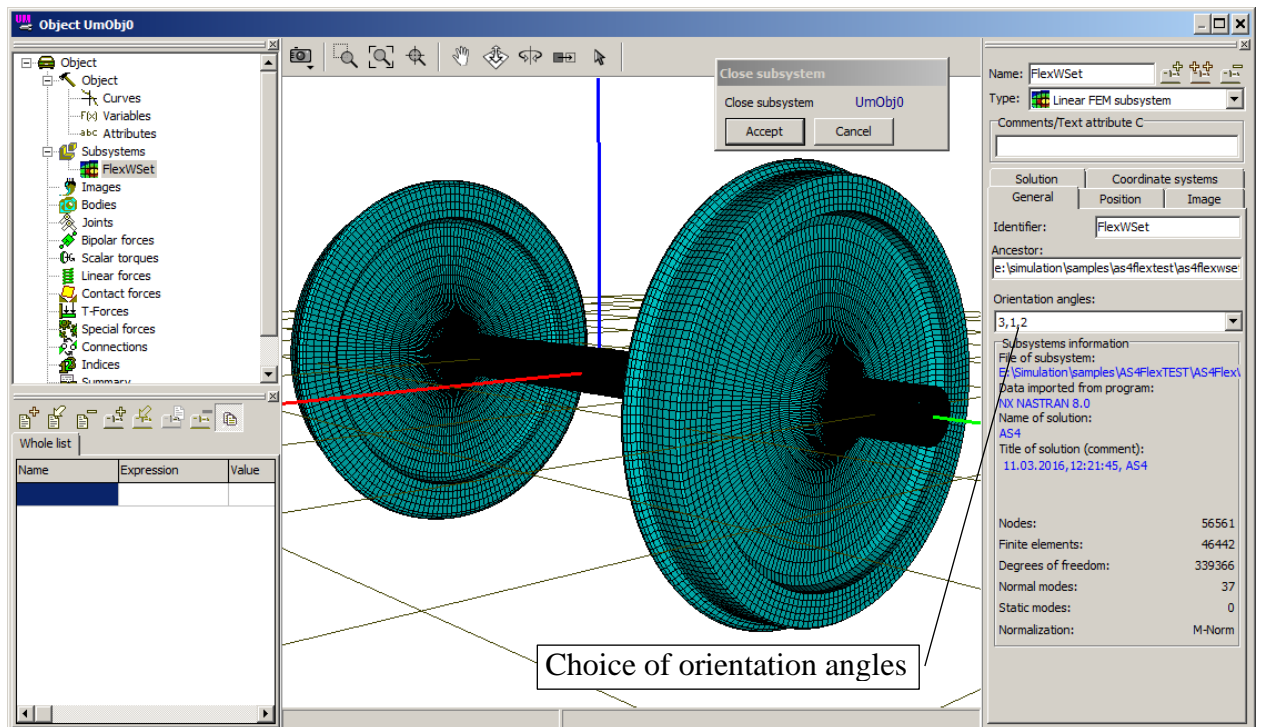

Figure 28.17. Editing FE model of the flexible wheelset in the mode of addition of an **included** subsystem

In the simplest case, it includes only flexible subsystem prepared in accordance with p. 28.4.1. However, there are no limitations on addition of other components to the model. Thus, the *included* subsystem is added to the model of rail vehicle. The *flexible subsystem* modelling

flexible wheelset is the required component of the added *included* subsystem. The flexible subsystem *must be the first* one in the subsystems list of added subsystem.

If the subsystem does not meet the requirement mentioned above in p. 28.4.1, the message presented in Figure 28.18 is outputted in the screen and it is suggested to delete the subsystem. A user can keep it and continue editing the vehicle model. However he must replace the incorrect model of flexible wheelset by the correct one before start of simulation. Otherwise, the model cannot be loaded in **UM Simulation** program.

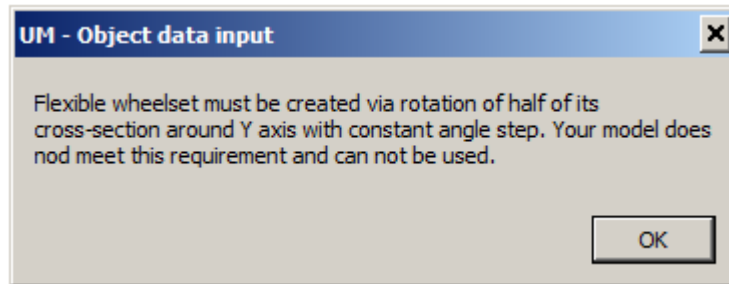

Figure 28.18.

User can test the model of the flexible wheelset included in the vehicle by clicking the **Summary** item in the **Object tree**. The message about the incorrectness of the wheelset is shown in the panel of **Object inspector**.

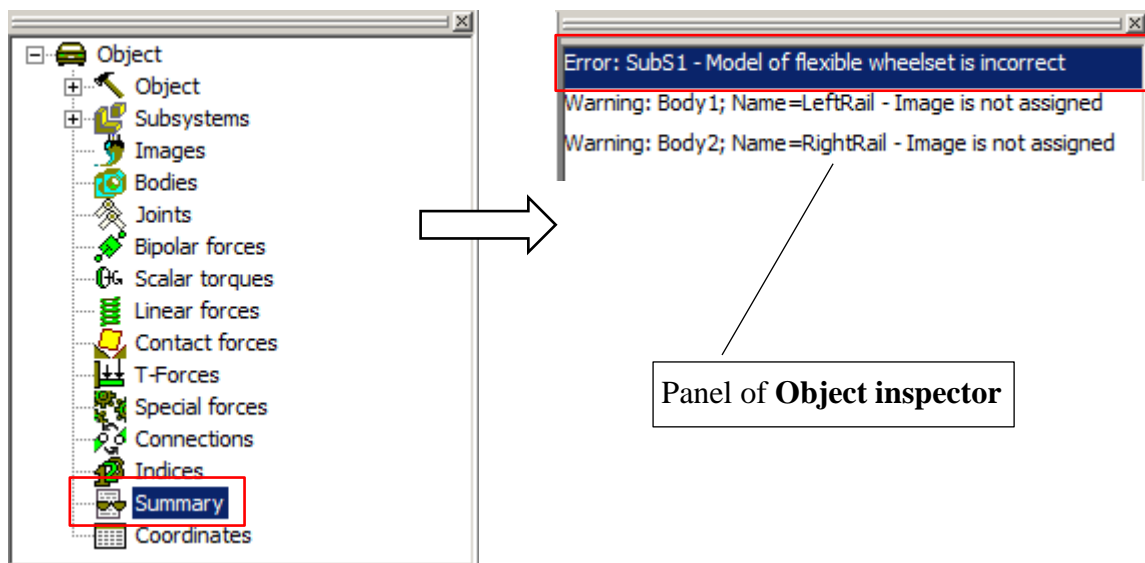

Figure 28.19. Results of testing object data with incorrect flexible wheelset.

In accordance with the methods presented in [Chapter 11](#), a single body and joint **6 d.o.f.** are introduced for the flexible subsystem. They are not represented in the **Tree of elements**. The choice of the sequence of orientation angles (3, 1, 2) is the requirement for the model of the flexible wheelset (see Figure 28.17).

Note the model of rigid wheelset includes two bodies: the base body *WSet* having five degrees of freedom and gyrostat *WSetRotat* with the single rotational degree of freedom around axle of the wheelset (see p. 8.1.3.2 of [Chapter 8](#) “Wheelset with six degrees of freedom”). This approach allows connecting force elements like springs to body *WSet*. That is, the interaction

with the wheelset can be simulated directly. For the flexible wheelset, intermediate bodies simulating axle-boxes should be introduced and the force elements are connected to them.

After editing of the subsystem, push button **Accept** in order to save the changes.

Let us create the model of rail vehicle AS4 with the flexible wheelset by the replacement of the front rigid wheelset by the flexible one.

Download archive [um\\_samples\\_fws.zip](#) from website [www.universalmecchnism.com](http://www.universalmecchnism.com). This archive includes directory **AS4FlexWSet** containing the ready model of railcar AS4 with the flexible wheelset. It can be used for quick study the rules of creating such models as well as for comparison with the model and calculation results which will be obtained in this manual.

Directory **FlexSSWSetAS4** including subsystem “**Flexible wheelset**” is placed into directory **AS4FlexWSet**.

After unpacking the archive, copy directory **{Unpacking directory}\AS4FlexWSet\FlexSSWSetAS4** to folder **Flex** in **UM** examples directory. Here, {Unpacking directory} is the directory to which the archive is unpacked.

Thus, the model of the flexible wheelset should be placed on the following path: [{UM Data}\SAMPLES\Flex\FlexSSWsetAS4](#).

Let us pass to creating the railcar model. Run **UMInput** program, load the model of AS4 from directory [{UM Data}\SAMPLES\Rail\\_Vehicles\ac4](#) (Figure 28.20) and save it to the new working directory by button  on the tool panel. The new model of railcar is called **AS4FlexWSet**.

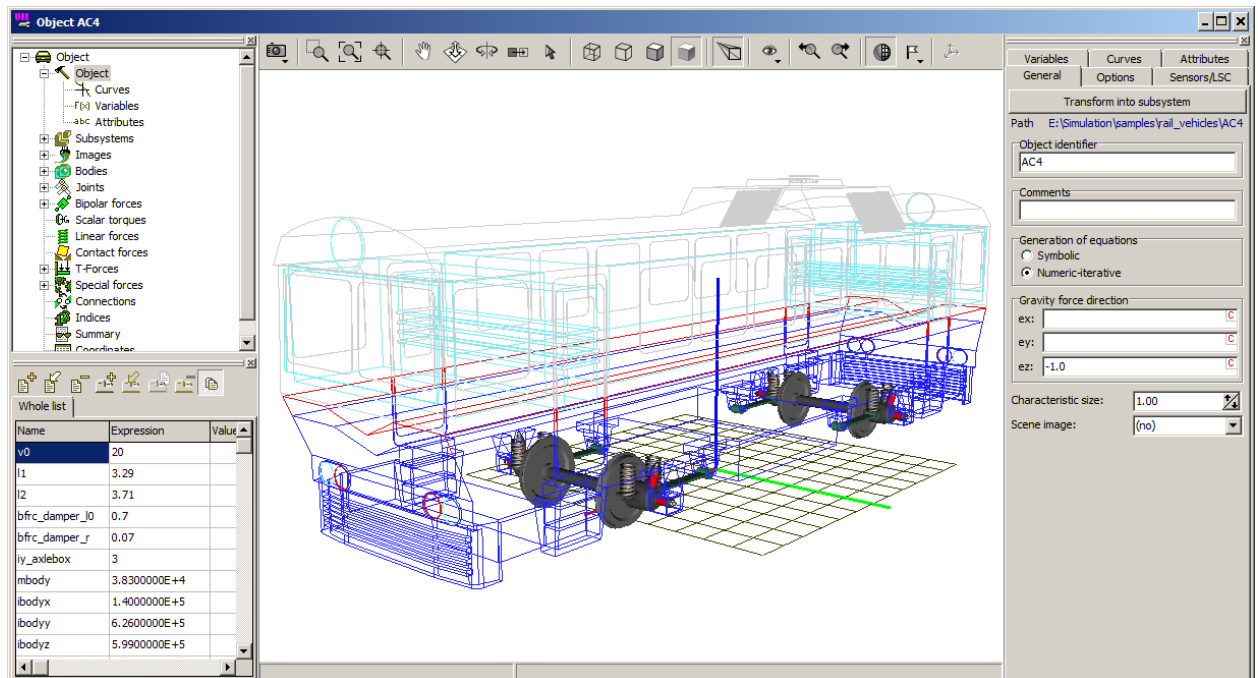

Figure 28.20. Model of railcar AS4 from the set of models supplied with **UM**

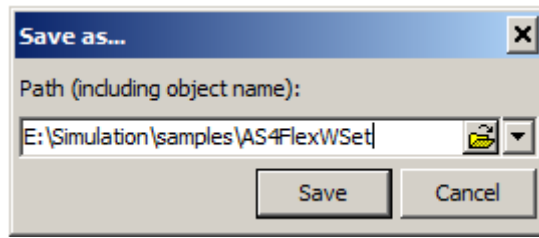



Figure 28.21. Saving of the model AS4 in the new directory for the following editing

Let us select the front wheelset **Wheelset1** in the list of subsystems, change it type on **Flexible wheelset** and start of its editing by button **Edit subsystem**. In the opened window of **Object constructor**, select **Subsystem** in **Tree of elements**, add new subsystem by button , select subsystem type **Linear FEM subsystem** and load it from directory [\[UM Data\]\SAMPLES\Flex\FlexWSetAS4](#) (Figure 28.22). Set name **FlexWSet** for the subsystem.

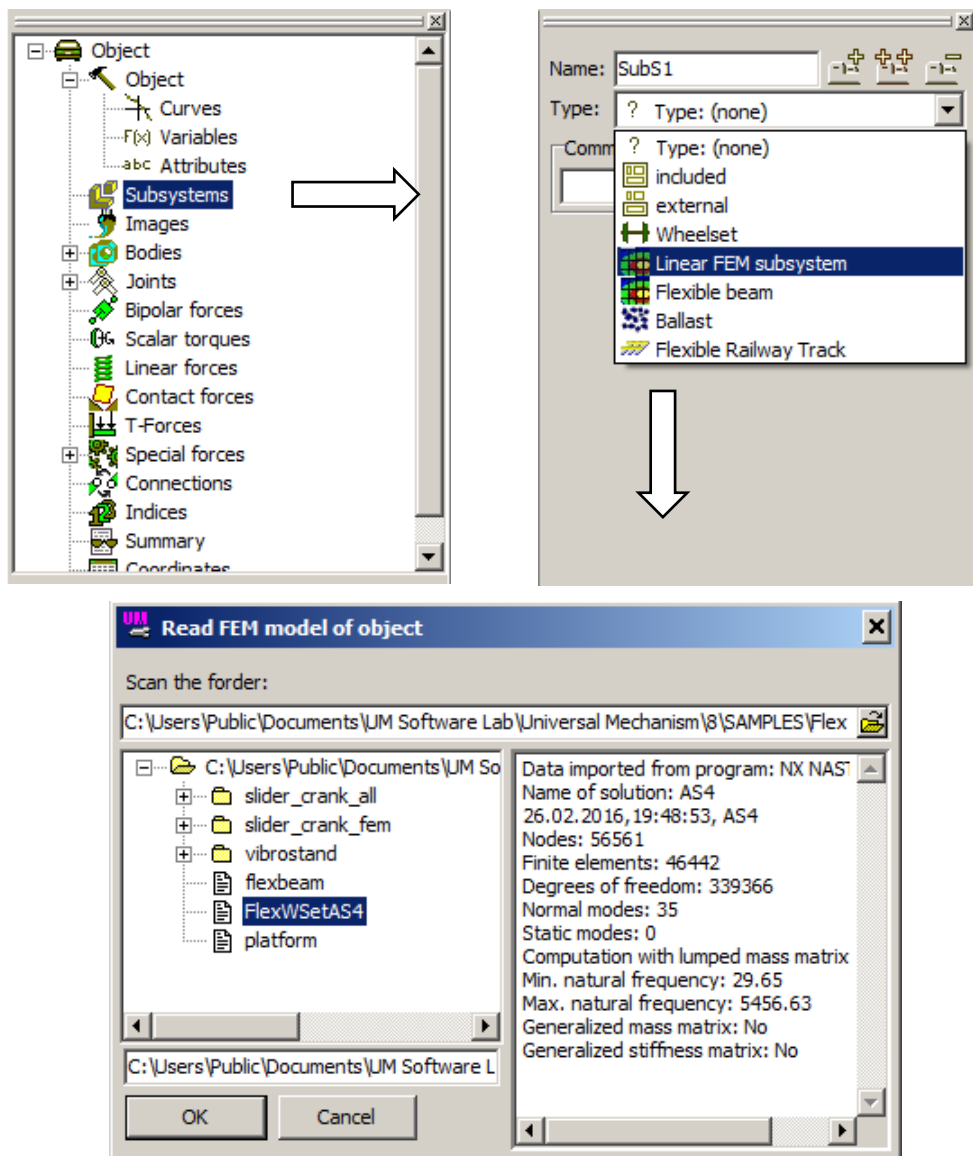



Figure 28.22. Addition of a new flexible wheelset

### 28.5.2. Introduction of auxiliary coordinate systems

Let us introduce auxiliary coordinate systems for calculation of radial and tangential stresses of the wheels. Let us select nodes-sensors on the circle with radius 0.3756 meters with the angle step  $30^\circ$ . Zero angle value corresponding to the vertical radius directed down from rotation axis. Axis Z of introduced SC will coincide with the radial direction from wheel rim to the rotation axis; axis X will correspond to tangential direction; axis Y is parallel to Y of the local SC of wheelset. Every auxiliary SC is defined by an origin and by three orientation angles relative to the local SC. Let us use the visual way of defining the auxiliary SC with the subsequent correction of the orientation angles.

Select **Coordinate systems** tab on the form of flexible subsystem. Press button  and sequentially select nodes specifying the origin, X axis and XY plane of the coordinate system.

Note visual choice of the nodes is possible only if button  of animation window is pressed. Its state should be checked. After selecting the nodes shown in Figure 28.23, the form fields are filled by the values presented on the left of Figure 28.24. Set name **SC0** to added SC and edit the fields of **Orientation** group as it is shown on the right of Figure 28.24.

Eleven remaining SC are introduced similar. Their names, origin coordinates and rotation angle around Y axis are presented in table 28.1. Two other rotation angles are zero. All introduced SC are shown in Figure 28.25.

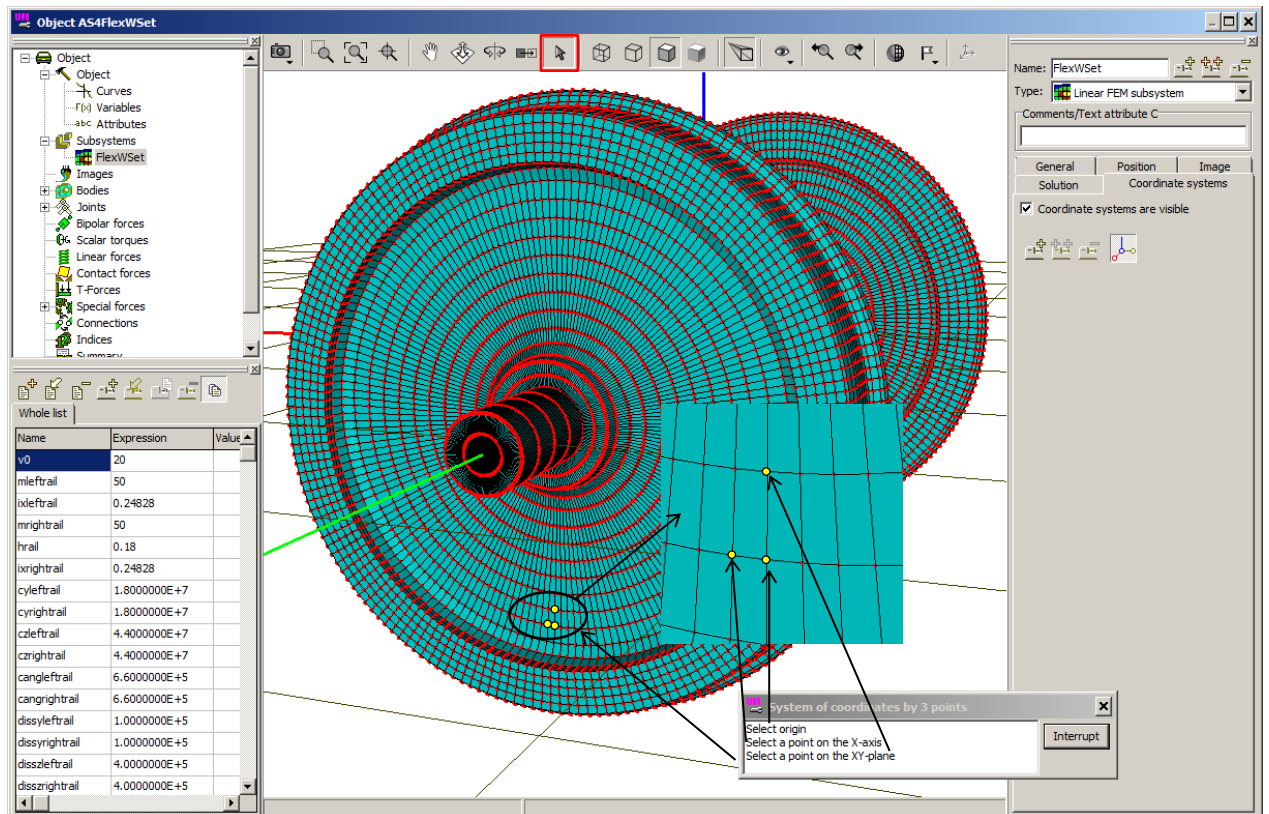

Figure 28.23. Visual input of the auxiliary SC for the flexible wheelset

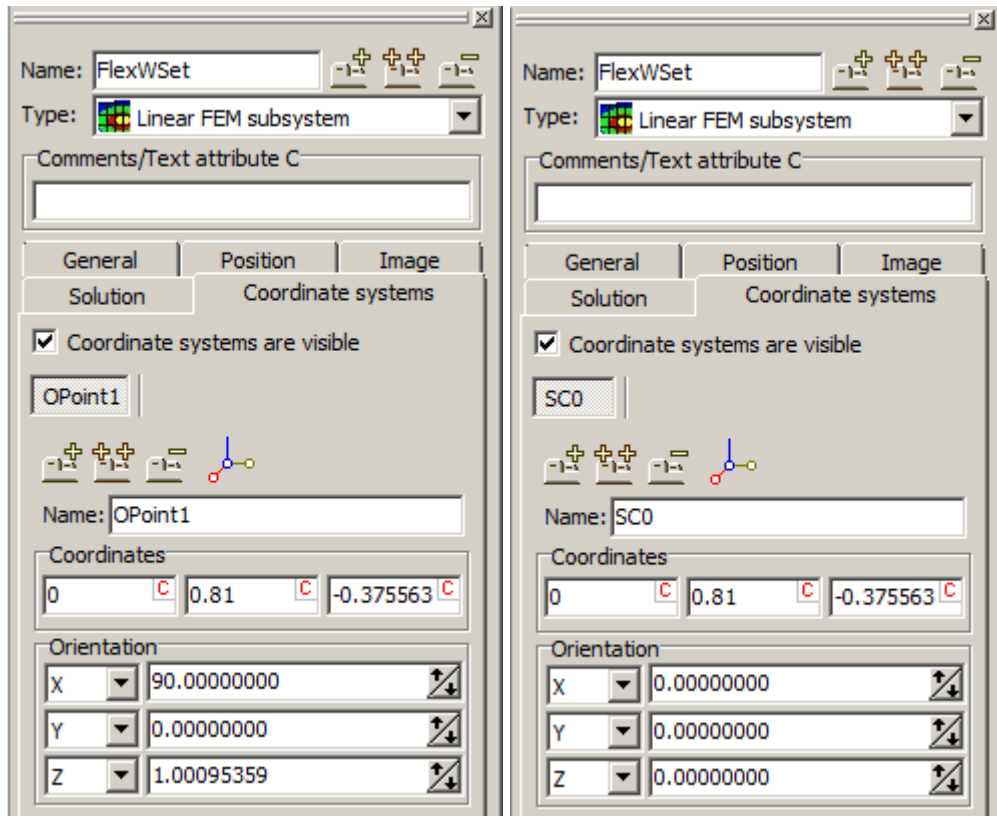

Figure 28.24. Editing of orientation of auxiliary SC for flexible wheelset: state after visual input is on the left, after editing is on the right

Table 28.1.

The auxiliary coordinate systems of flexible wheelset **FlexWSet**

N <sub>o</sub>	Name	Node index	X	Y	Z	$\varphi_y$
1	SC 0	14372	0.0000	0.8100	-0.3756	0
2	SC30	16742	-0.1878	0.8100	-0.3252	30
3	SC60	19112	-0.3252	0.8100	-0.1878	60
4	SC 90	21482	-0.3756	0.8100	0.0000	90
5	SC120	23852	-0.3252	0.8100	0.1878	120
6	SC150	26222	-0.1878	0.8100	0.3252	150
7	SC180	55	0.0000	0.8100	0.3756	180
8	SC 210	2522	0.1878	0.8100	0.3252	-150
9	SC 240	4892	0.3252	0.8100	0.1878	-120
10	SC 270	7262	0.3756	0.8100	0.0000	-90
11	SC 300	9632	0.3252	0.8100	-0.1878	-60
12	SC 330	12002	0.1878	0.8100	-0.3252	-30

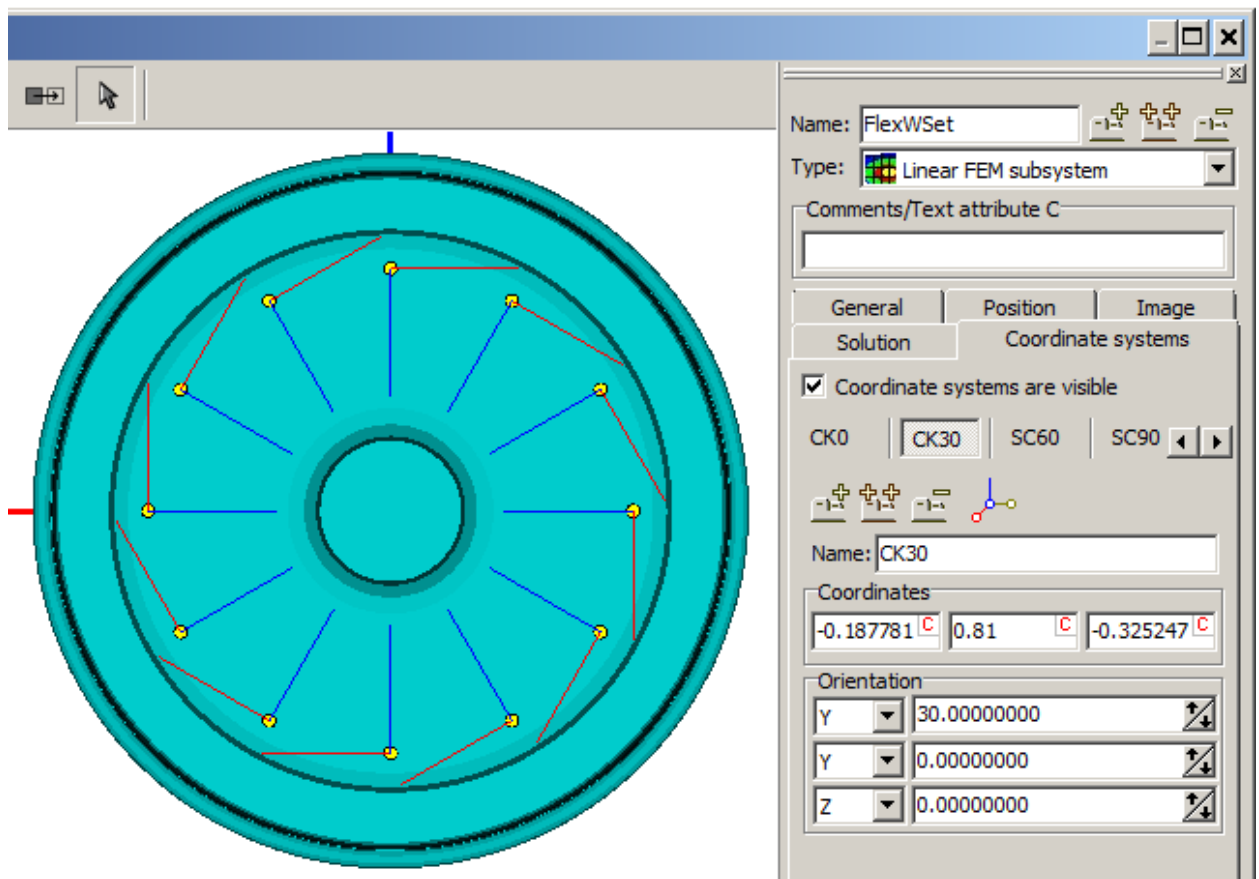

Figure 28.25. Image of the added SC in the animation window

### 28.5.3. Editing of model AS4 after introduction of flexible wheelset

The descriptions of the rotational joints connecting wheelset become incomplete after change the rigid wheelset by the flexible one because the first body is not defined (see Figure 28.26 on the left). Let us consider the left axle-box as the example. In the source model of AS4, the rotational joint **jAxle-box LF** was the single one introduced for the axle-box. It specified the path from the axle box through wheelset to basic body **Base0** in the kinematic graph of the model (see [Chapter 2](#) of User’s manual, p. 2.2.1 “Connectivity of systems and definition of a joint”).

In fact, change of the wheelset type means deletion of *included* subsystem **Standards wheelset** and addition of subsystem **Flexible wheelset** including *external* subsystem type of **Linear FEM subsystem**. The axle-boxes should be connected with this FEM subsystem via rotating joints. In this case, the path from axle-box to basic body cannot be found automatically. That is, the program “does not see” the axle-box. Therefore, only choice of body **AS4FlexWSet.FlexWSet.AS4** as the first body of rotational joints **jAxle-box LF** (Figure 28.26 on the right) and **jWSet\_Axle-box RF** is not enough for correct description of railcar kinematics. The joints **6 d.o.f.** must be introduced for each axle-box for connection them with the base (Figure 28.27). Coordinates of the joint points in the local SC of axle-boxes are (0,0,0).

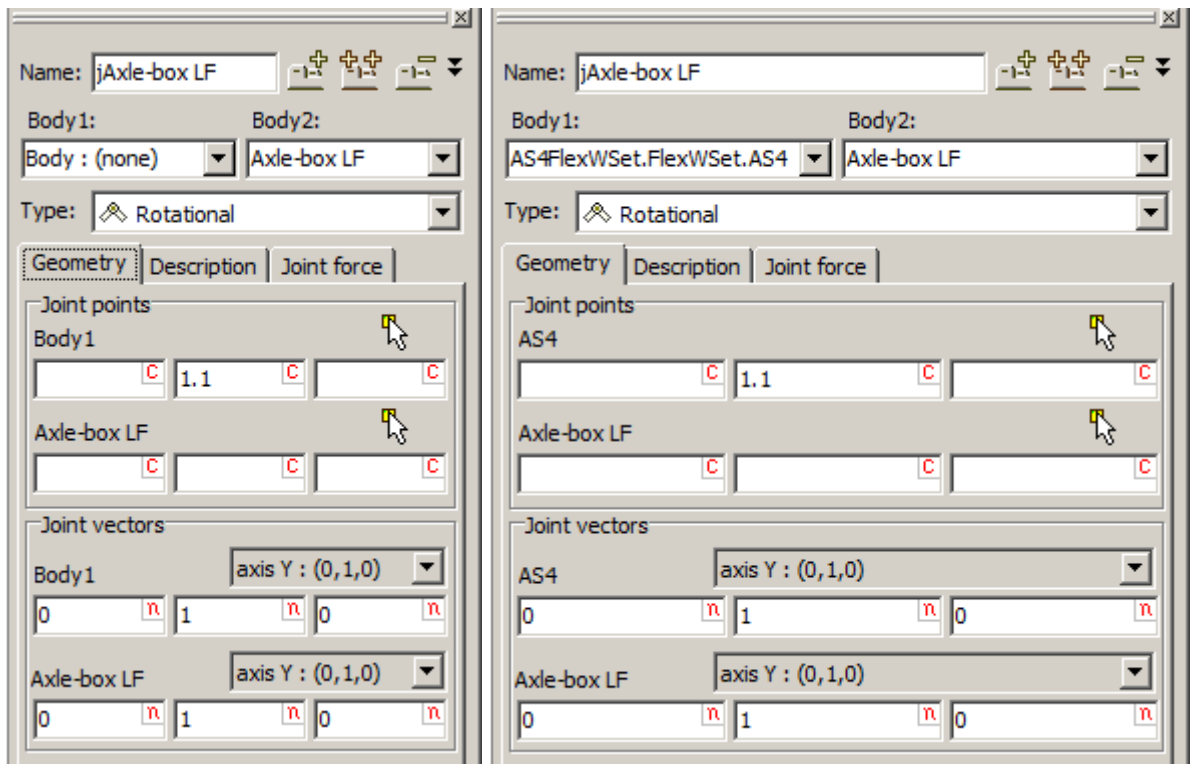

Figure 28.26. Editing of rotational joint connecting the flexible wheelset and left axle-box

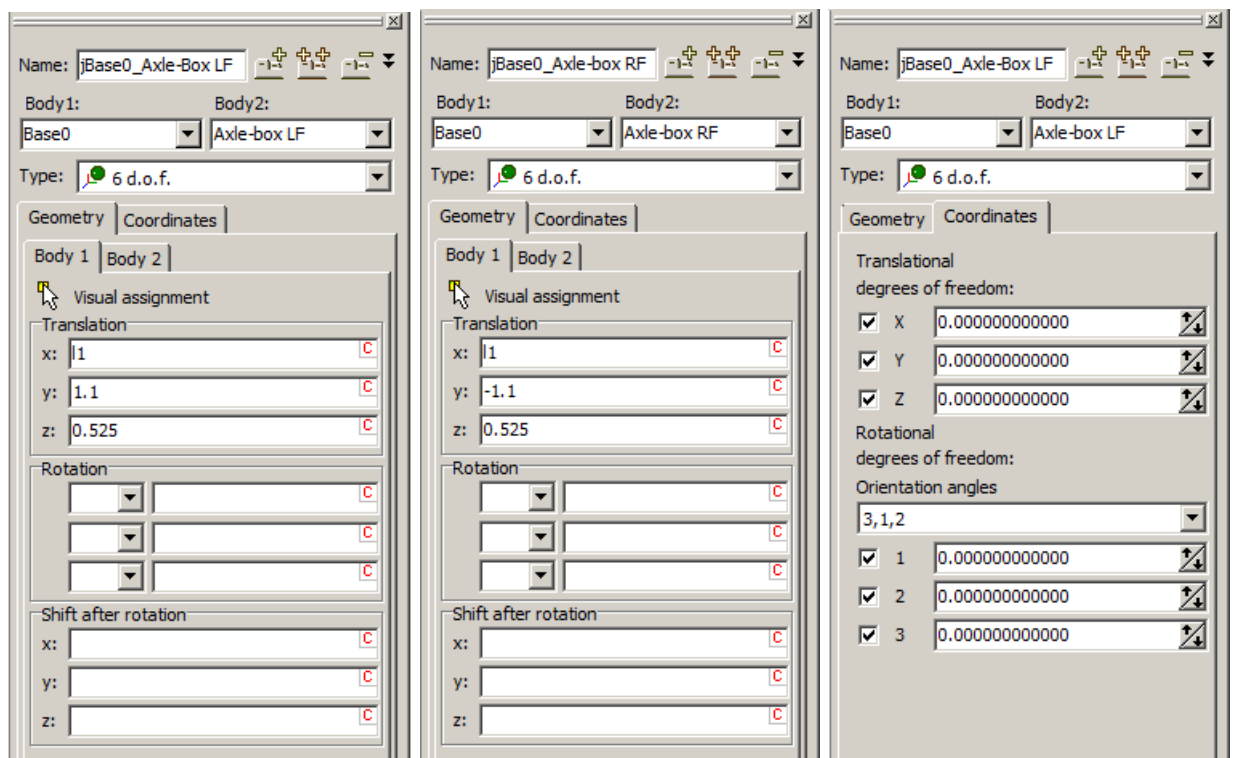

Figure 28.27. Adding the joint 6 d.o.f. for bodies Axle-box LF and Axle-box RF

Creating of AS4 model is finished. Save the changes and pass to the simulation.

## 28.6. Simulation of wheelset dynamics in UM Simul program

Preparation of numerical experiments with rail vehicles is described in p. 8.4 of [Chapter 8](#) “Simulation of rail vehicle dynamics”. If a flexible wheelset is included in a vehicle model, tab **Flexible wheelsets** is added onto tab **Rail/Wheel** of **Object simulation inspector**. With the help of this tab, the approach to simulation of flexible wheelsets can be selected in accordance with the description presented in pp. 28.3.3.1, 28.3.3.2 as well as the interpolation order for Euler approach (Figure 28.28).

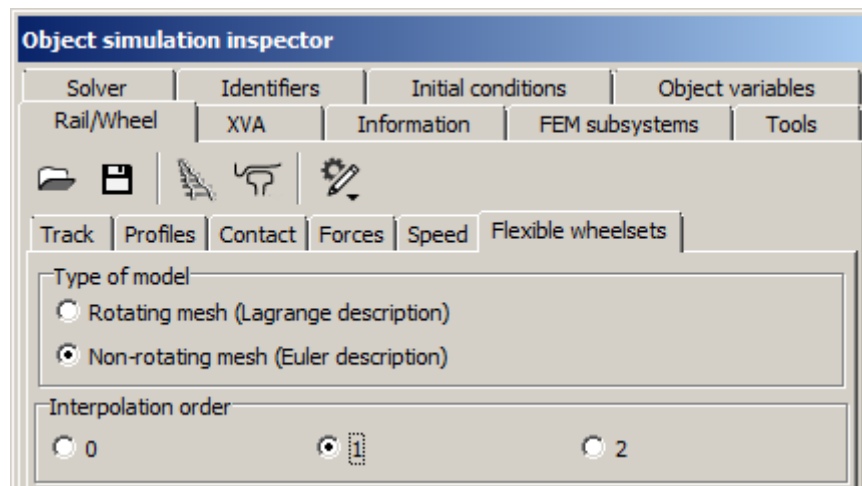

Figure 28.28. Tab **Flexible wheelsets** of **Object simulation inspector**

### 28.6.1. Wizard of variables

Flexible wheelset dynamics is analyzed via variables which are created on tab **Flexible wheelset** of **Wizard of variables** (Figure 28.31). Flexible wheelsets are presented by the simple list without tree structure. A name of each element is formed using the following rule:

$$\textit{Element name} = \textit{'Wheelset ' + wheelset index + ' (' + subsystem name + ')'},$$

where *wheelset index* is wheelset index in a single vehicle or train taking into account *all* wheelsets independently from their type, *subsystem name* is wheelset subsystem name defined in **UM Input** program.

Field **Sensor** contains the node selected for the analysis by the button or the popup menu. The form of selection of the node-sensor is shown in Figure 28.32.

The following kinds of analysis are available:

- Kinematics;
- Stresses;
- Drawing.

The form contains three tabs of the same name corresponding to each kind of analysis.

The sequence of creating and use of variables is described below.

*Kinematics.*

With the help of this tab, variables for calculation of flexible kinematic characteristics of the nodes are created. The flexible characteristics are displacements, velocities and accelerations occurring due to flexible deformations:

$$\mathbf{r}_{kf} = \mathbf{H}_k \mathbf{w}, \quad \mathbf{v}_{kf} = \mathbf{H}_k \dot{\mathbf{w}}, \quad \mathbf{a}_{kf} = \mathbf{H}_k \ddot{\mathbf{w}},$$

where  $k$  is the node index,  $f$  means the flexible term of the value i.e. the motion of wheelset as rigid body is not taken into account.

A variable is defined by the following parameters (Figure 28.31):

- type;
- component;
- approach to calculation;
- coordinate system relative to which the value of variable will be presented.

The list of coordinate systems includes elements “Local SC of subsystem”, “Cylindrical” and all auxiliary SC introduced for the subsystem in **UMInput** program (p. 28.5.2).

If “Cylindrical” SC is chosen, components correspond to the following directions: X is tangential direction, Y is lateral one coinciding with Y axis of the local SC, Z is radial direction (Figure 28.30).

Option **Calculation approach** is explained below. It can have one of two values: **Lagrange** and **Euler**.

Let intermediate coordinate system  $x_c y_c z_c$  is connected with the wheelset. The orientation of this  $SC_c$  relative to the global  $SC_0$  is defined by the rotation angles around Z and X axis (the first and the second angles in the angle sequence (3, 1, 2) of the wheelset), the rotation angle around Y is zero (the third angle of the sequence). That is, the intermediate SC moves with the wheelset but does not rotate around Y axis.

Let us suppose that in the initial instant  $t = 0$ , an analyzed node was placed in point  $K_0$ , and its position is in point  $K_\alpha$  in the current time after rotation of the wheelset on angle  $\alpha$ . If Lagrange approach is applied, the variable is calculated in point  $K_\alpha$ . If Euler approach is used, the value is computed in point  $K_0$ . Its coordinates are constant in the intermediate coordinate system  $SC_c$ . In other words, we observe the material point of the wheelset in the case of Lagrange approach and the point of space moving together with the wheelset if Euler approach is applied.

Note the settings **Calculation approach** for variables and **Type of model** defined in **Object inspector** should be distinguished (Figure 28.28). These settings are defined independently. Their combination defines the calculation method of variable: either using modal matrix of the node-sensor or via interpolation of values in the nodes nearest to point  $K_0$  in the presented instant. The all possible settings are presented in table 28.2.

Table 28.2.

The calculation method of variables in the dependence of the settings

Type of model	Calculation approach	Calculation method for variable
Rotating mesh (Lagrange)	Lagrange	Node matrix
Rotating mesh (Lagrange)	Euler	Interpolation
Nonrotating mesh (Euler)	Lagrange	Interpolation
Nonrotating mesh (Euler)	Euler	Node matrix

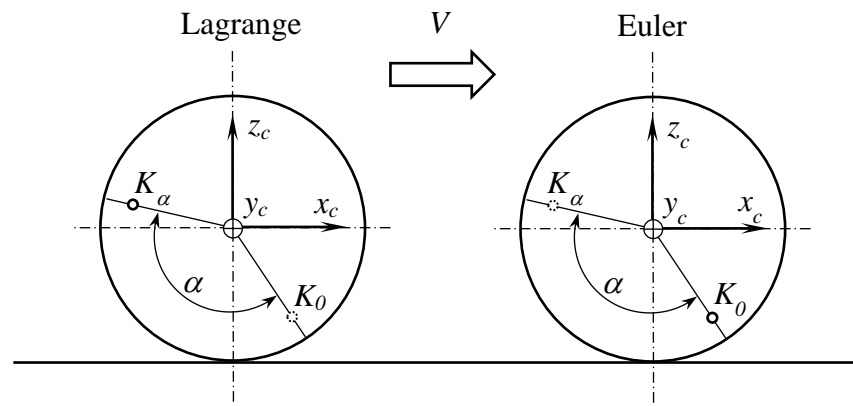

Figure 28.29. The explanation of option **Calculation approach** of a variable

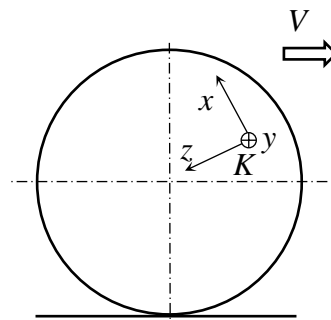

Figure 28.30. The components of kinematic characteristics of node  $K$ .

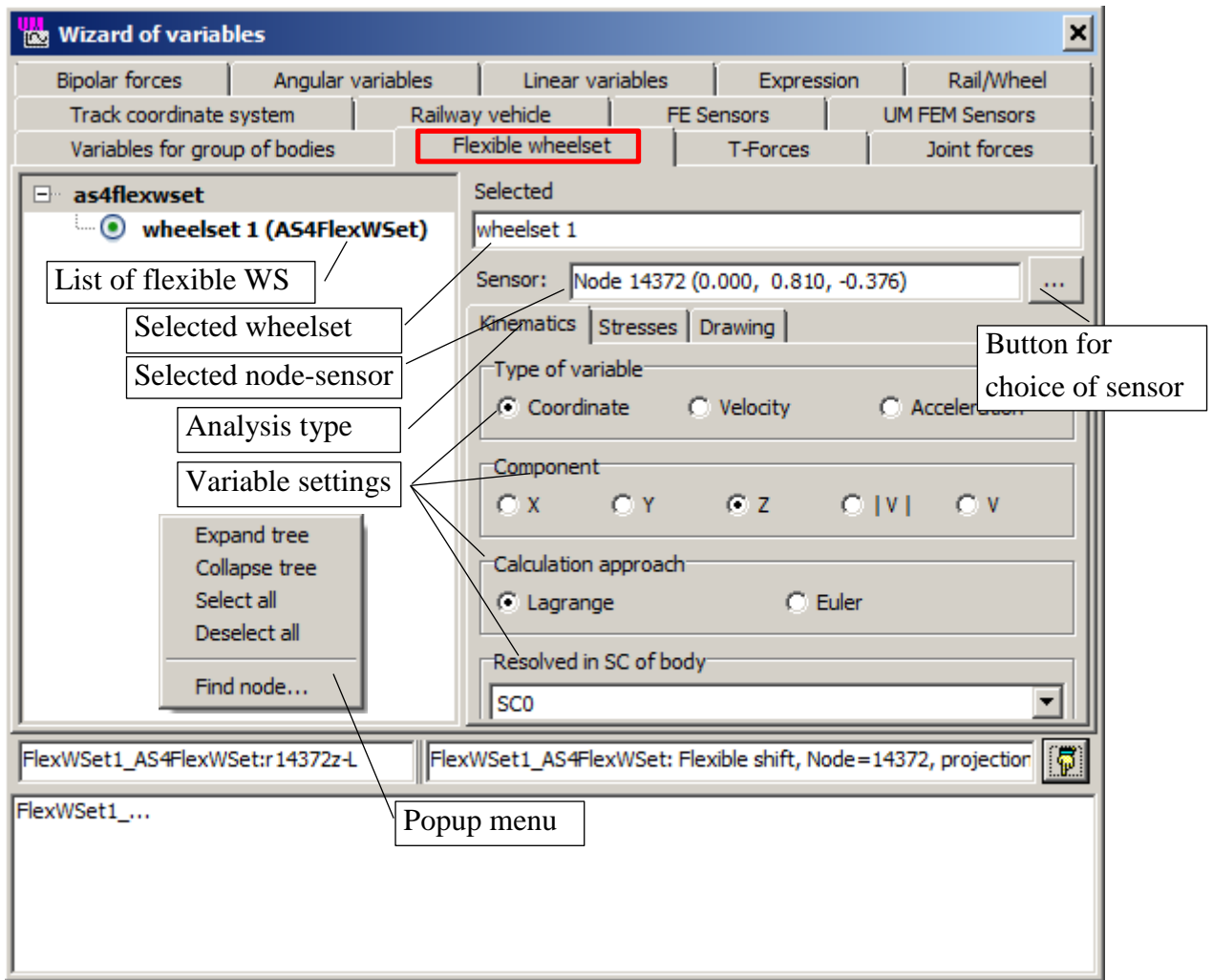

Figure 28.31. Tab **Flexible wheelset** of **Wizard of variables**

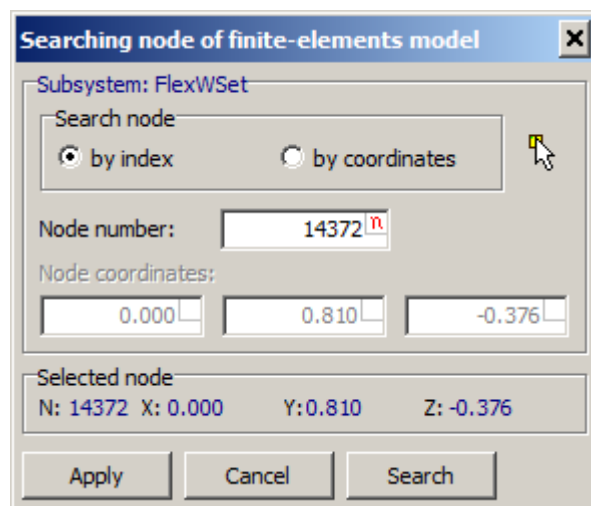

Figure 28.32. Form for searching node

An identifier of variable are formed using the following rule:  
 Identifier = 'FlexWSet' + wheelset index + '\_' + subsystem name + ':' + type of the variable + index of node-sensor + component + '-' + calculation approach. For example,  
*FlexWSet1\_AS4FlexWSet:r14372z-L.*

The designation of variable type can be the following:  $r$  is displacement,  $v$  is velocity,  $a$  is acceleration; designation of calculation approach:  $L$  is Lagrange approach,  $E$  is Euler one.

The comment to variable contains additional information about coordinate system relative to which the value is calculated. For example:

*FlexWSet1\_AS4FlexWSet: Flexible displacement, Node=14372, projection Z (Lagrange), relative to SC "Local SC of subsystem".*

*Stresses.*

Using this tab, variables for calculation of stresses are created after defining the following parameters (Figure 28.33):

- group of elements;
- component;
- approach to calculation;
- coordinate system relative to which the value of variable will be presented.

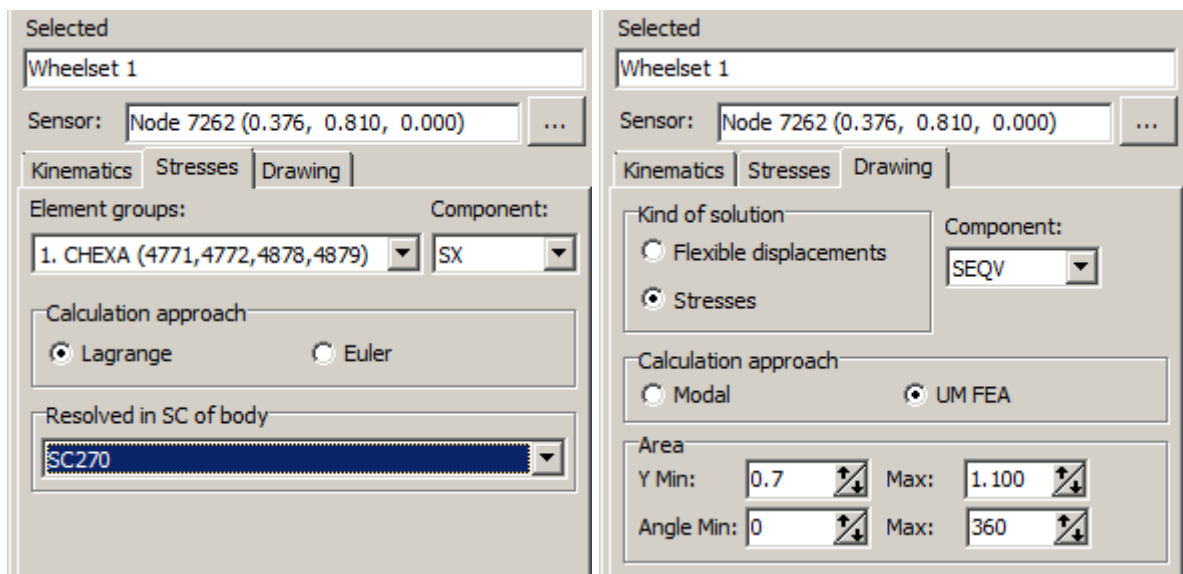

Figure 28.33. Tabs **Stressess** and **Drawing**

Drop-down list **Finite elements** consists the single element with a type name and indices of finite elements including selected node-sensor. This list does not give a choice because the wheelset model includes finite elements of the single hexahedral type (except prisms placed around Y axis).

Drop-down list **Component** consists the six components of the stress tensor, principal and equivalent stresses: SX, SY, SZ, TXY, TYZ, TXZ, P1, P2, P3, PEQV. The symbols correspond to designations in the FEA program from which data was imported. The names of stresses component used in NX NASTRAN are presented above.

The value of **Calculation approach** defines analyzed point and method of calculation of stresses as it is described for kinematic variables.

Values of variables created with the help of this tab are computed applying the internal library of **UM** without use of imported stresses data (see p. 11.1.2 of [Chapter 11](#) “Calculation of stresses and strains”). For analysis of stresses using imported data, variables should be created with the help of **FE Sensors** tab of **Wizard of variables** (see p 11.5.3.3 of of [Chapter 11](#) “Stresses and strains”).

For calculation of stresses applying UM procedures, the material properties must be specified. In general case, they are not imported from FEA programs. The material of the flexible wheelsets is assumed to be isotropic. Thus, Young modulus and Poisson ratio are required for stresses calculation. Their values are set on tab **FEM subsystems** → **Solution** → **Materials** of **Object simulation inspector** Figure 28.34. They must be equal to the corresponded material properties inputted in the external FEA program from which the data is imported.

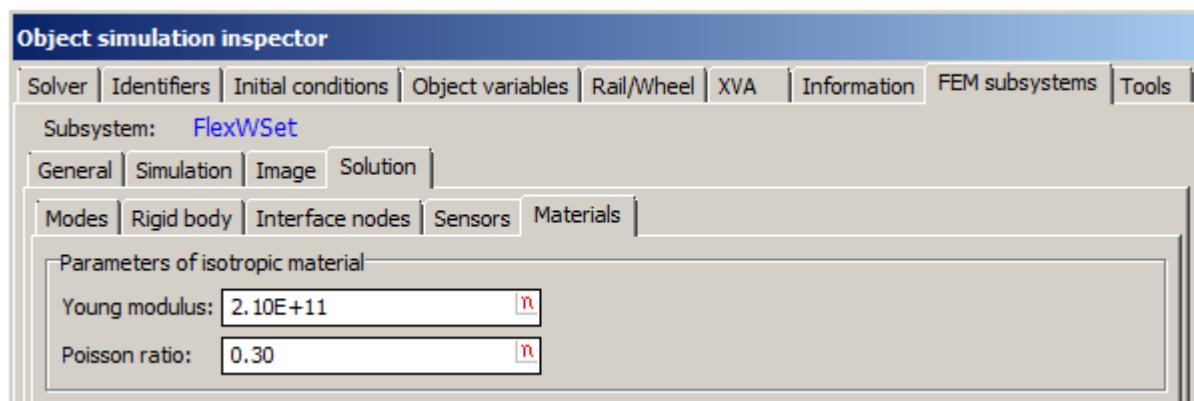

Figure 28.34. Input properties of wheelset material

#### *Drawing.*

On this tab, the variables of type *drawing* are created for display of calculation results in an animation window. The colors corresponding to the calculated values and selected scale are set to each node on the painted area of the wheelset surface.

A drawing variable is defined by the following parameters (Figure 28.33):

- kind of solution;
- component;
- calculation approach, it is available for solution kind **Stresses** only;
- painted area.

Components defining the directions of **Flexible displacements** are the same ones as described above for **Kinematics** tab: X is tangential direction, Y is lateral one, Z is radial displacement (Figure 28.30).

**Calculation approach** can take the values **Modal** and **UM FEA**. Modal approach means stresses calculation using imported data. In order to use this approach, the sensors must be created in whole drawing area in the stage of preparing the model in external FEA program.

The internal library of finite elements is used if **UM FEA** option is selected. Therefore whole surface of the wheelset can be drawn. However, calculation of the solution and painting the results require much computer resources and can slow down the simulation noticeably. From other side, it can be enough information about state of the part of the surface for estimation of loading because of symmetry of the wheelset.

Group **Area** of the form elements allows defining the drawn part of the wheelset surface. It is specified by the fourth parameters: minimal and maximal Y values ( $y_{\min}$ ,  $y_{\max}$ ), minimal and maximal values of the angle defining painted sector ( $\varphi_{\min}$ ,  $\varphi_{\max}$ ). These parameters are presented in Figure 28.35. The angle is measured from vertical lower radius; it can take values from 0 to

360 degrees. If the sector designated  $\alpha_1$  should be drawn,  $\varphi_{\max}$  should be inputted in filed **Angle Min** and  $\varphi_{\min}$  in filed **Angle Max**.

An identifier of variable is formed using the following rule:

*Identifier* = 'PS \_' + subsystem name + '\_' + component.

For example, *PS\_AS4FlexWSet\_SEQV*. PS is the abbreviation of “Painted Solution”.

A created variable should be drag and drop on an animation window in which drawn wheelset will be displayed. The variable is added to the list of drawing variables. Visibility and position of this list is specified via popup menu (Figure 28.36).

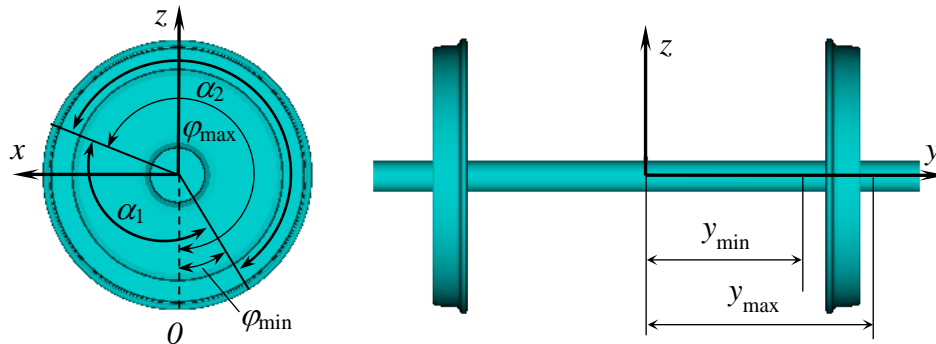

Figure 28.35. Example of defining painted area of wheelset

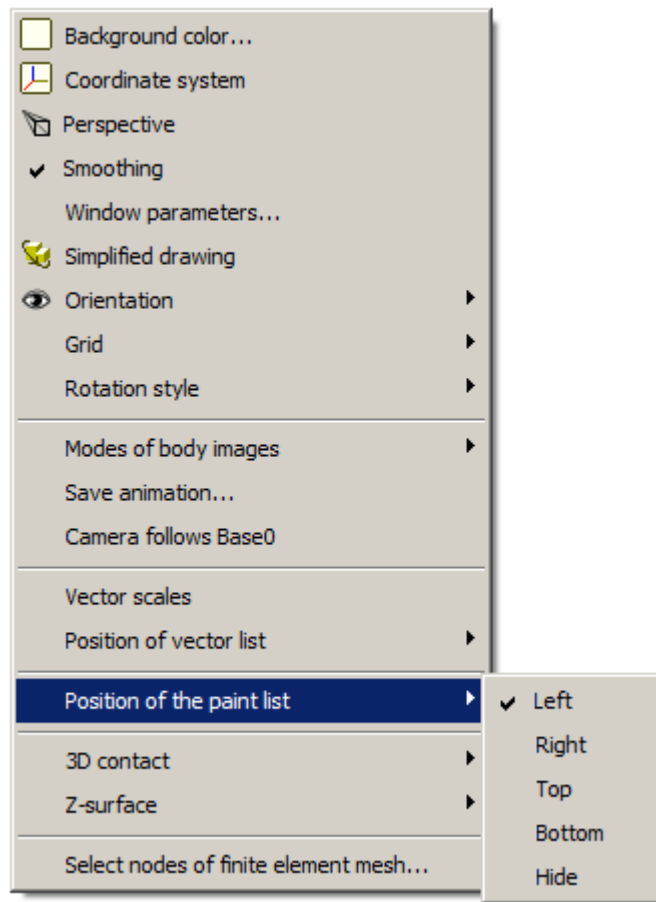

Figure 28.36. Choice of position of the paint list in the animation window

A variable can be “switched on/off” by the check box of the list element. If the variable is switched off, the calculation of solution is stopped and the wheelset is drawn in accordance with its graphical object options.

The tuning of the variable is carried out with the help of the screen form that is called by double click on the element of drawing list (Figure 28.37). The drawing scale is specified by three colors which are set to the minimal, mean and maximal values. The values range can be selected automatically or set by user. If the automatic choice is applied, the color assigned to field **Maximal value** will be set to node with the maximal value of the solution. If **Upper bound** is specified “manually” then “maximal” color will be assigned to all values exceeding upper bound. The similar rule is set for the minimal value.

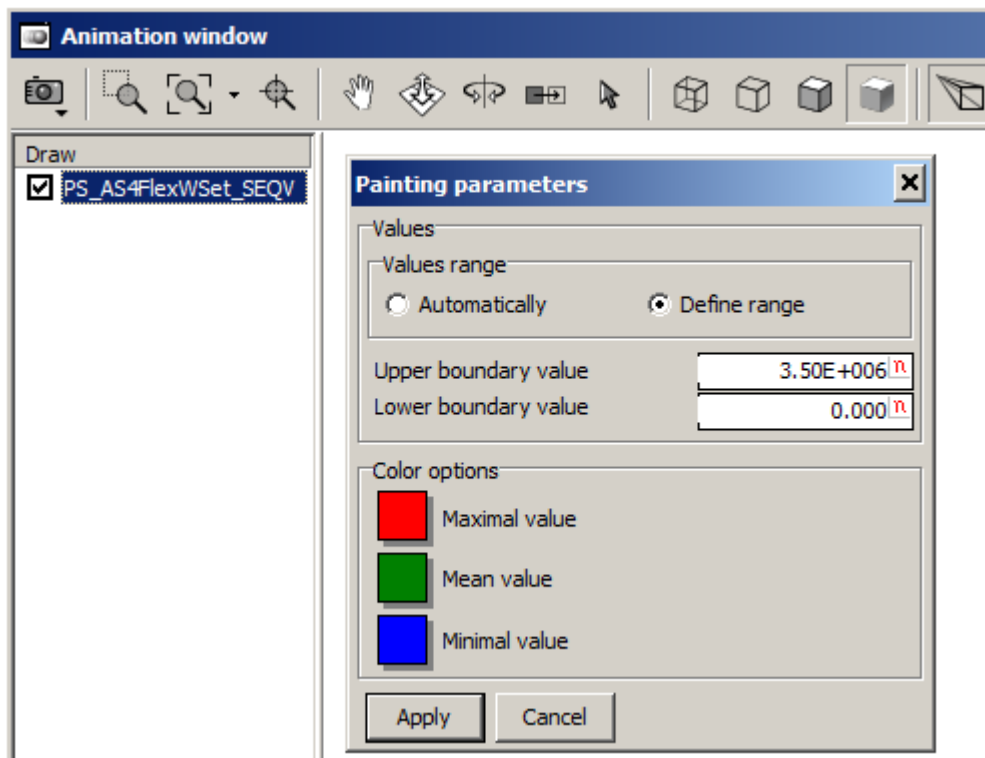

Figure 28.37. List of variables and form for setting of drawing parameters

Note if the list includes several variables drawing the same wheelset area, the solution calculated by last variable will be shown in the animation window. Such situation is senseless and even adverse because of *all* variables are calculated; the computer resources are expended and the simulation can slow down sharply. Therefore in the similar cases, it is recommended to switch off all variables except the variable observed in the current time.

### 28.6.2. Simulation example

In this section, the example of dynamic simulation of railcar AS4 with the flexible wheelset is considered.

The following numerical experiments are executed:

- moving in the straight track without irregularities with the speed 80 km/h;
- moving in the curve taking into account irregularities with the speed 80 km/h.

The flexible displacements, accelerations and stresses in the radial and tangential directions are analyzed in three nodes which are placed in the origins of auxiliary coordinate systems SC0, SC120 and SC240 (Figure 28.38, see also p. 28.5.2). Besides, the stress state of the left wheel is estimated via painting in the animation window in accordance with the equivalent stresses in the nodes.

At the beginning, equilibrium position should be calculated.

### 28.6.2.1. Creating variables

Use of the variables for analysis of the flexible wheelset dynamics will be considered below in the simulation example of railcar AS4. Creating the model is described in p 28.5.

The examples of creating the variables are shown in Figure 28.39 and Figure 28.40. Let us make the pairs of variables applying Lagrange and Euler approaches for each characteristic shown in graphical windows.

It is recommended to form the variable list and save it in the task directory for the further use. (Figure 28.41., see also p. 4.3.3 of [Chapter 4](#) “List of variables”). The graphical windows should be created and tuned for each type of the calculated variables (see also p. 4.3.4 of [Chapter 4](#) “Graphical window”). All settings are recommended to save in *icf*-file using item of main menu **File->Save configuration->All options....** The example of graphical window is presented in Figure 28.42.

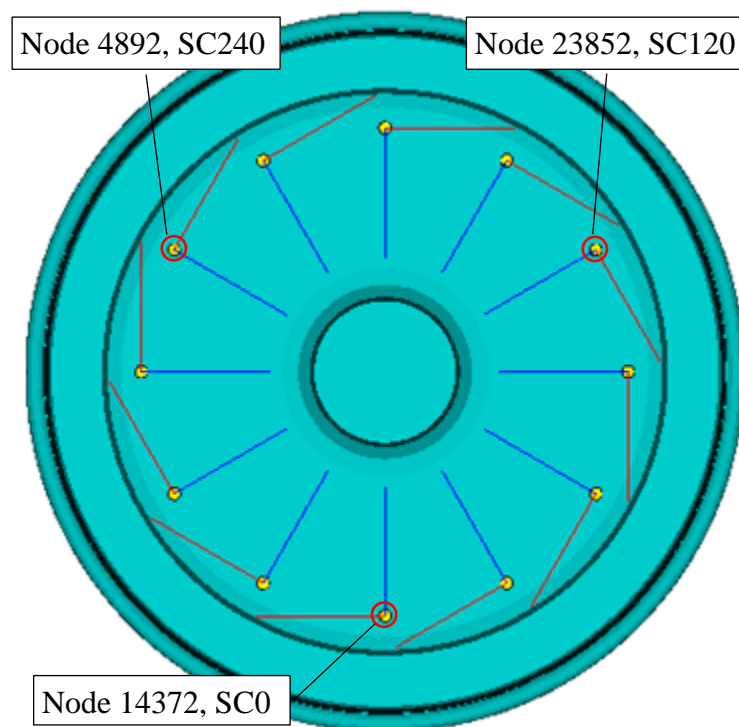

Figure 28.38. The nodes-sensors for creating variables in the simulation example

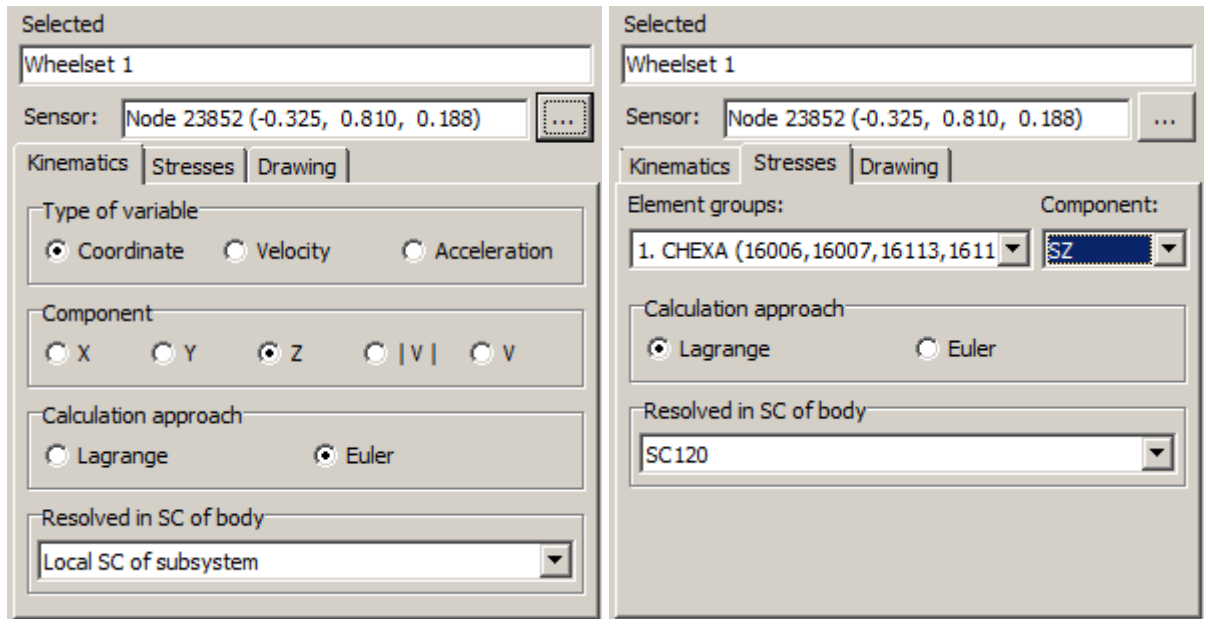

Figure 28.39. Variable settings for analysis of the radial flexible displacements in node 23852 applying Euler approach (on the left) and for analysis of radial stresses in node 23852 using Lagrange approach (on the right).

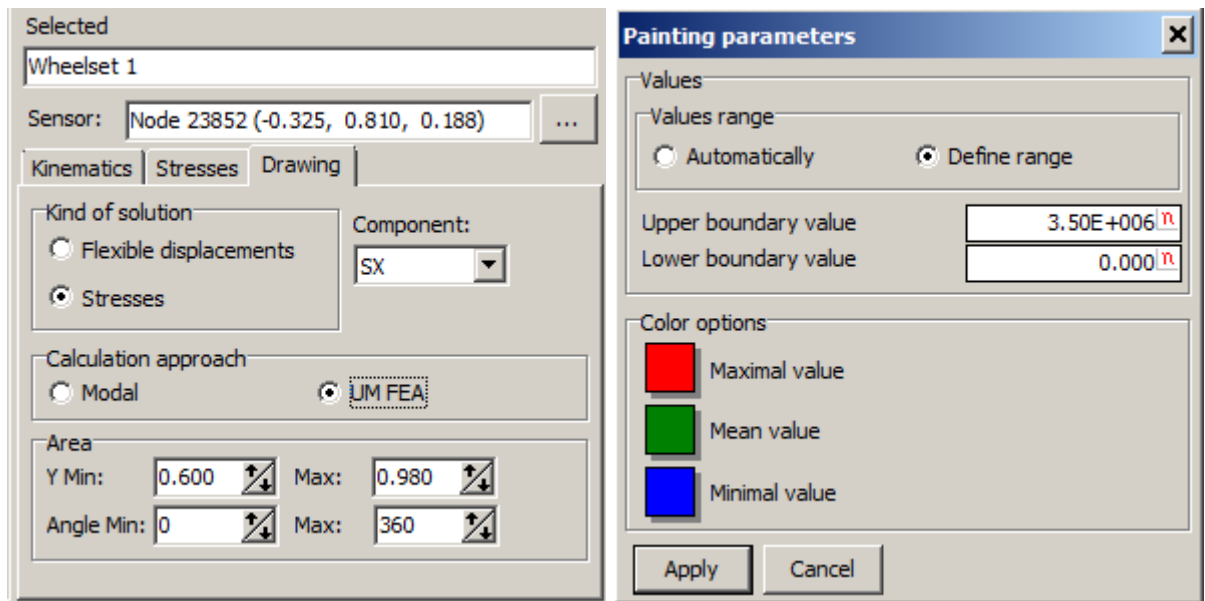

Figure 28.40. Variable settings for painting of the left wheel in accordance with the equivalent stresses in the nodes.

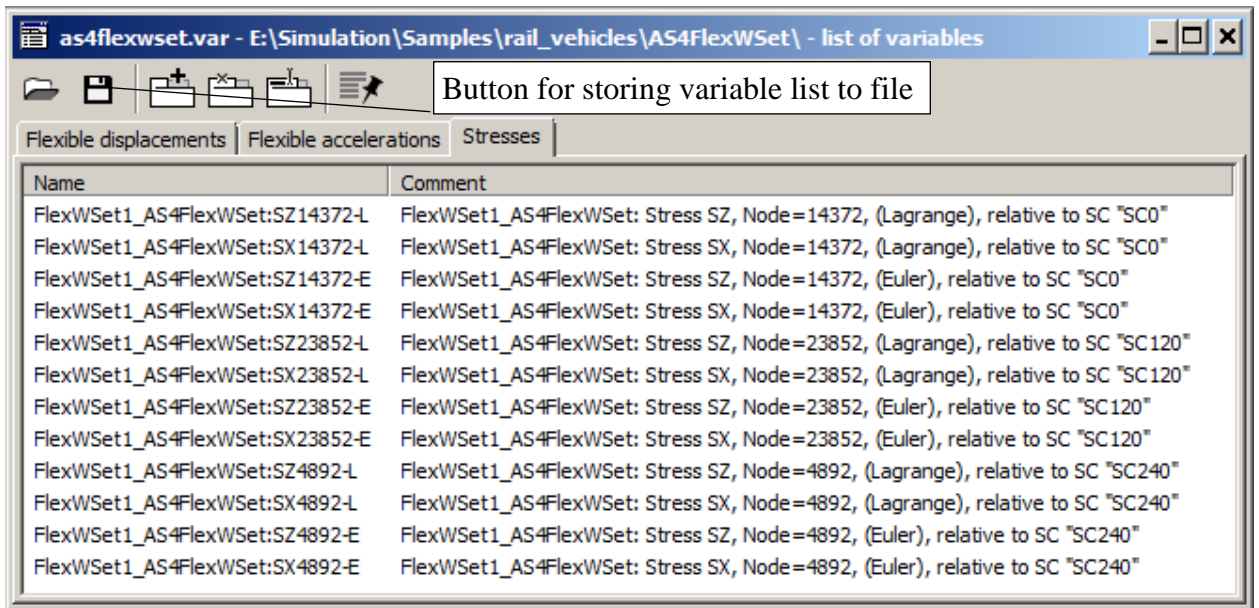

Figure 28.41. Variables list for the analysis of the flexible wheelset dynamics

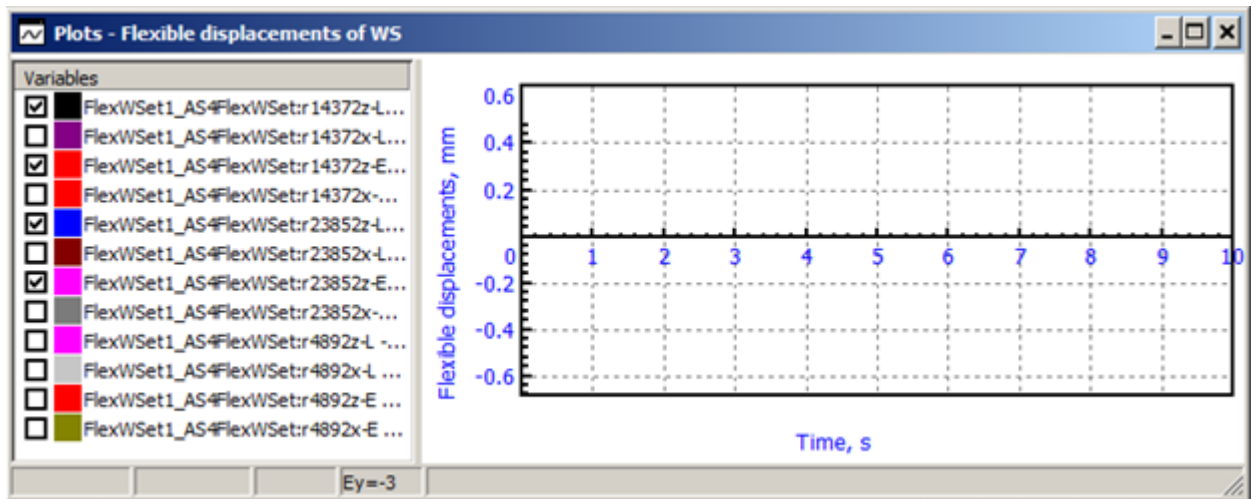

Figure 28.42. Example of the adjustment of the graphical window for presentation of displacement graphs

### 28.6.2.2. Calculation of equilibrium

Before calculation of an equilibrium position, the values of parameters should be set in the form of **Object simulation inspector** as it is shown in the figures below.

Solver parameters are presented in Figure 28.43.

Specifying of the internal damping of the flexible wheelset is shown in Figure 28.44 **Damping ratio for each mode** is chosen for **Type of definition** and the value 0.02 is inputted for the whole frequency range using the screen form called from the popup menu (see Figure 28.44).

Choice of the **Track model** and parameters is presented in Figure 28.45; **Massless rail** is chosen.

Some parameter settings of wheel-rail interaction are presented in Figure 28.46: **Mueller** is selected for the **Model of creep forces**, **Block wheelset shift aY** ( $v=0$ ) and **Rotating mesh** (Lagrange approach) for **Type of model** of flexible wheelset are chosen.

On tab **Rail/Wheel**→**Profiles** the wheel profile from file **newlocow.wpf** is set for all wheels of railcar AS4; the rail profile is set from file **r65new.rpf**.

Choice of other parameters of the wheel-rail interaction model is described in detail in [Chapter 8](#).

The equilibrium test is launched by button **Integration**. After the finish, the calculation results should be accepted as the initial conditions (Figure 28.47).

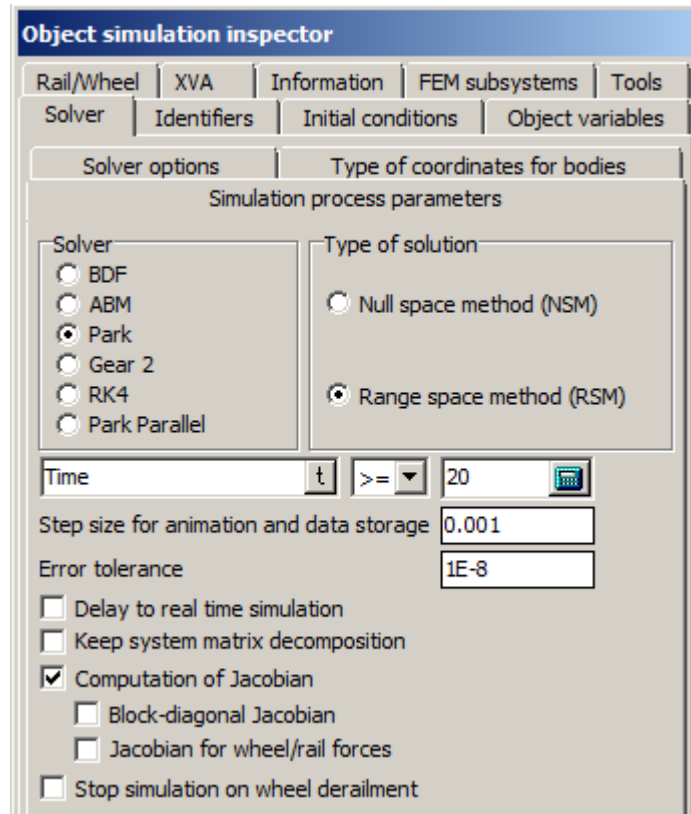

Figure 28.43. Settings simulation parameters of railcar AS4 with the flexible wheelset

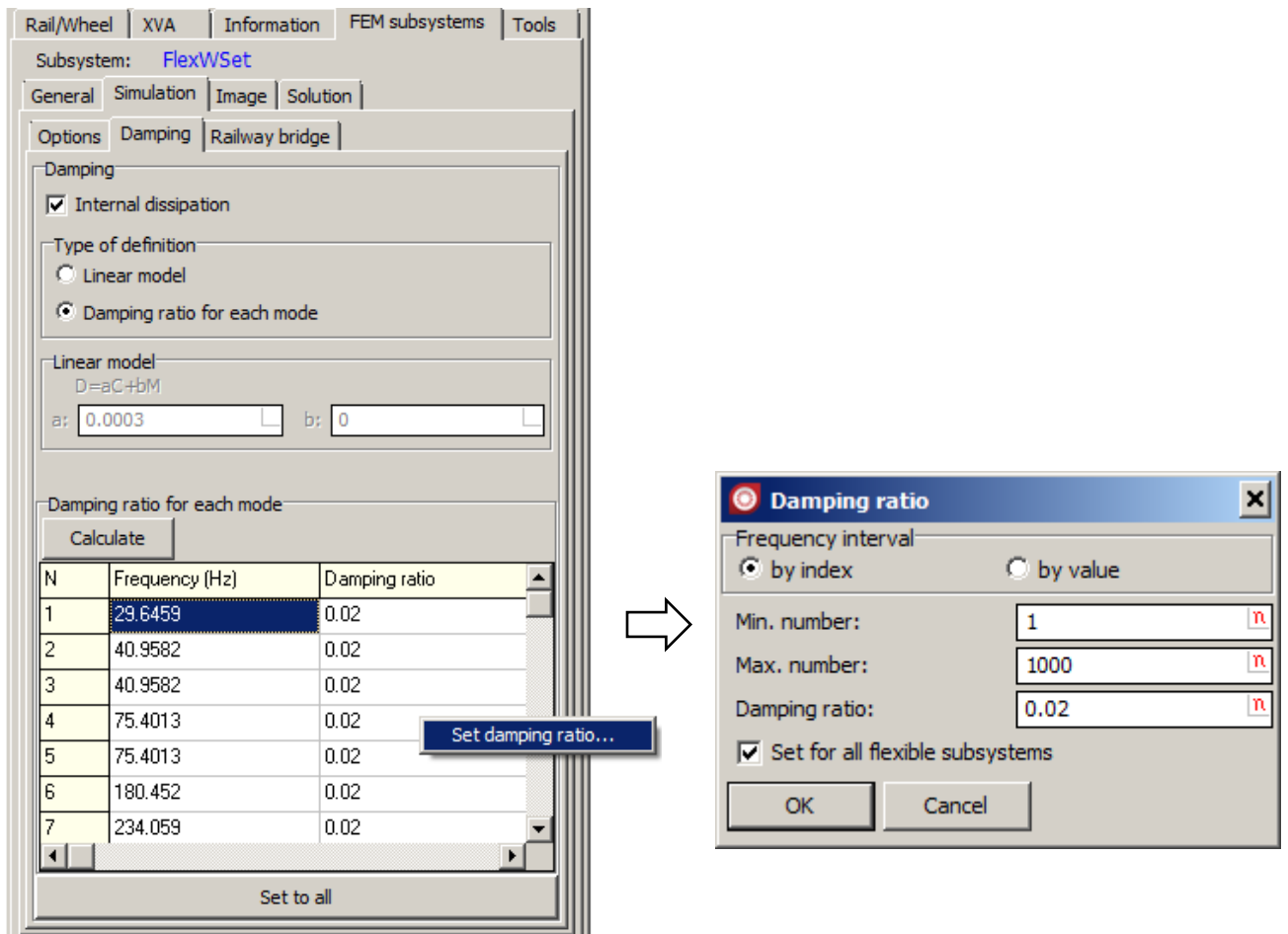

Figure 28.44. Input of parameters of internal damping of the flexible wheelset

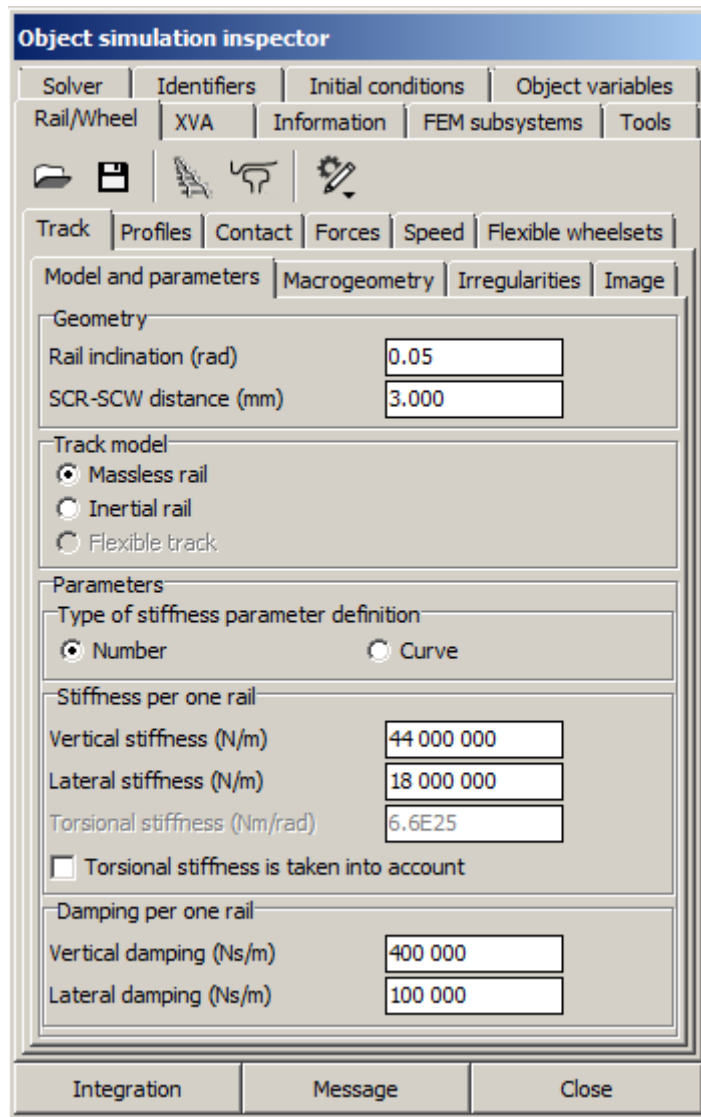

Figure 28.45. Choice of the model and parameters of the rail way

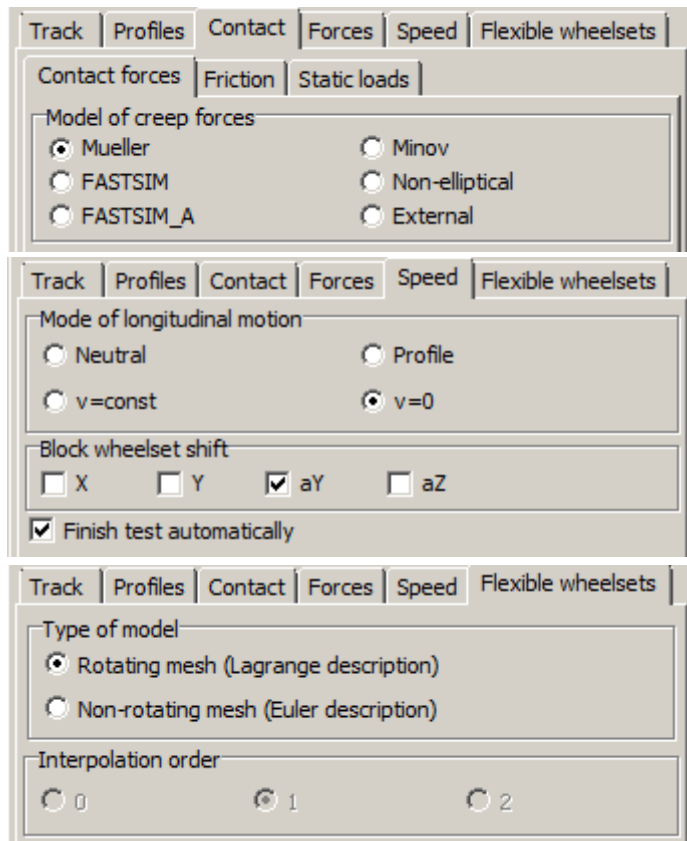

Figure 28.46. Settings parameters of the wheel-rail interaction

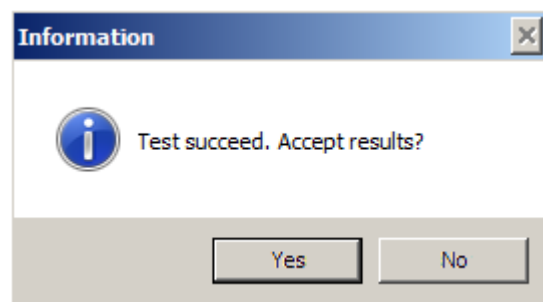

Figure 28.47. Calculation results are accepted as the initial conditions.

### 28.6.2.3. Moving in straight track without irregularities

In this item, the simulation of moving railcar AS4 with the speed 80 km/h (22.222 m/s) in the straight track without irregularities is considered. Corresponding settings in **Object simulation inspector** are shown in Figure 28.48. The simulation during 10 seconds is executed.

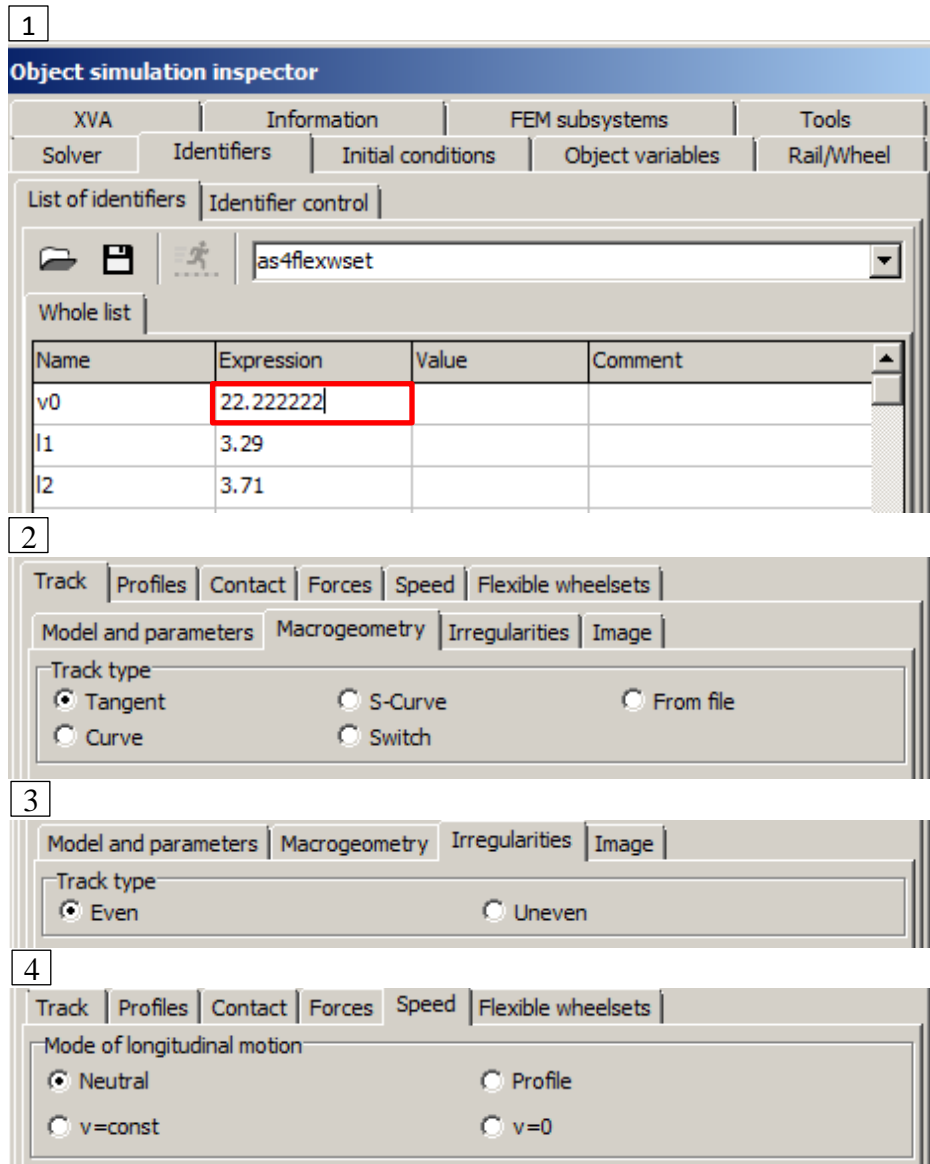

Figure 28.48. Settings for moving railcar in straight track with the speed 80 km/h

Let us consider the results. The graphs of the flexible displacements in the nodes 14372 и 23852 are presented in Figure 28.49.: all integration period and the two fragments. The first fragment includes the results in period 5.8...8.2 seconds. In the second one, the rotation angle of the wheelset around Y axis (it is coordinate 2.6 i.e. the sixth coordinate in joint **jBase0\_flexwsetas4**) is use as abscissa of the graph. In order to use the rotation angle as abscissa, the variable should be created as it is shown in Figure 28.50. It should be dragged and dropped to the graphical window and then selected as abscissa with the help of popup menu (see p. 4.3.4 “Graphical window” of [Chapter 4](#)).

The last fragment demonstrates graphically the differences in the approaches of variable calculations.

The displacement field is constant relative to global SC (as well as relative to SC connected to the wheelset and non-rotating with it) because of irregularities is absent and there are no disturbances from the rails.

The values of Euler variables are constant after short transient process. The graphs of Lagrange variables have the appearance like sinusoid. For each node, the values of Lagrange and Euler variables are equal when the node coincides with the point in which it was at the initial time  $t=0$ . The graph of Lagrange variable for node 14372 “touches” to the graph of Euler variable one time per revolution of the wheelset because it was on vertical radiuses in the lowest point of the trajectory at the initial instant. The similar graphs for node 23852 are intersected twice per revolution because of symmetry of the displacement field relative to the vertical axis. That is the radial flexible displacements in node 23852 and 4892 are identical (see Figure 28.38.). Note one more relationship confirming the correctness of the obtained results. The graph of Lagrange variable for node 23852 is shifted relative to the graph of node 14372, i.e. “lags”, on 240 degrees. It corresponds to the nodes relative positions on the wheel. The distances between the maximums or minimums of the graphs are equal to  $240^\circ$  и  $120^\circ$  when the rotation angle is the abscissa. In order to understand which graph “in front” the initial instant should be considered. When  $t=0$ , node 14372 was in the lowest point, node 23852 is placed in this point after rotation on  $240^\circ$  and the new turn of the wheelset starts after rotation on  $120^\circ$ .

The graphs of accelerations and stresses in the nodes-sensors look like displacement graphs (see Figure 28.51 – Figure 28.53).

The example of painting the wheel is shown in Figure 28.54.

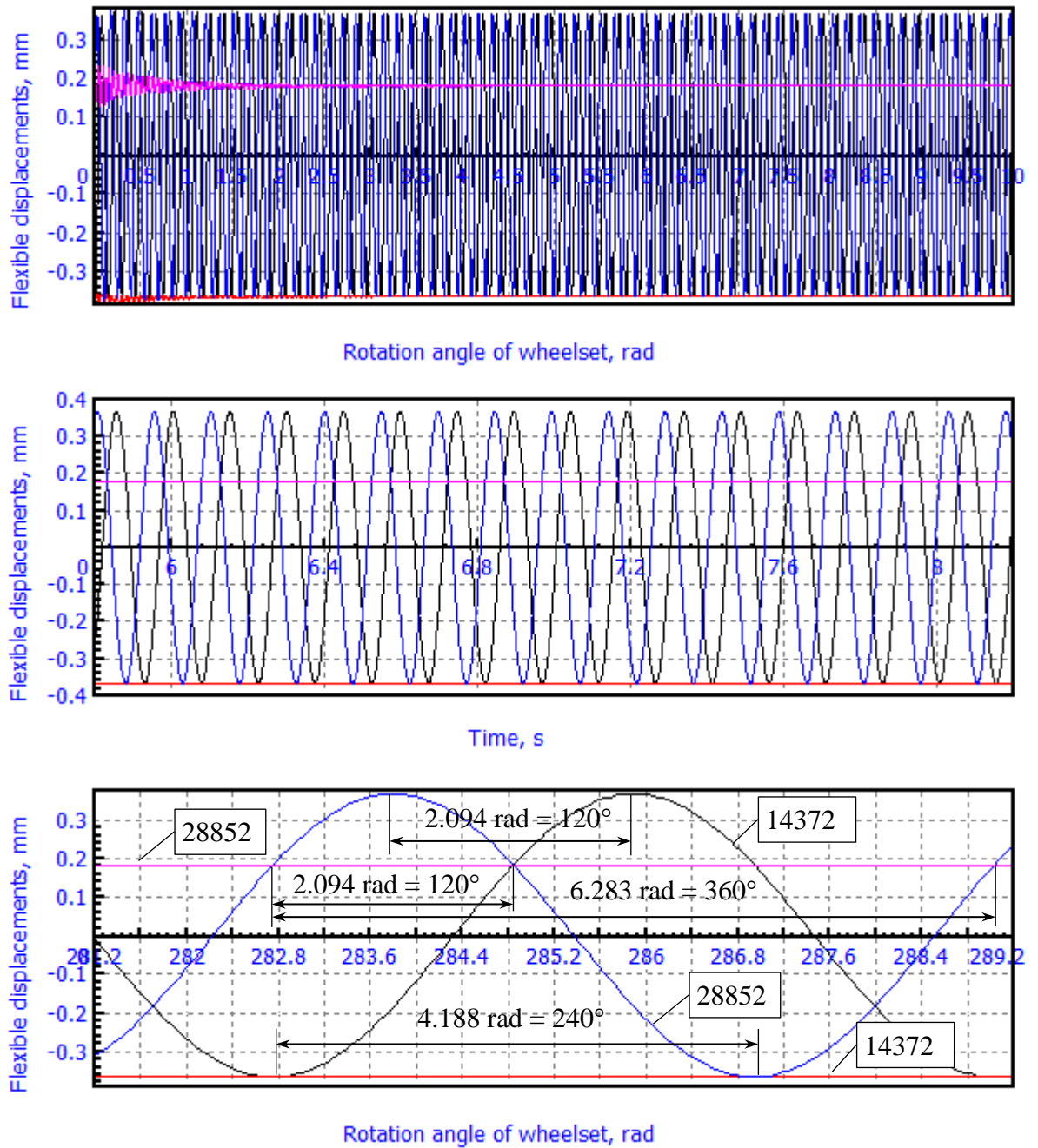

Figure 28.49. Flexible radial displacements when the railcar moves in straight track with the speed 80 km/h.

- – Node 14372, Lagrange approach; ■ – Node 14372, Euler approach;
- – Node 23852, Lagrange approach; ■ – Node 23852, Euler approach.

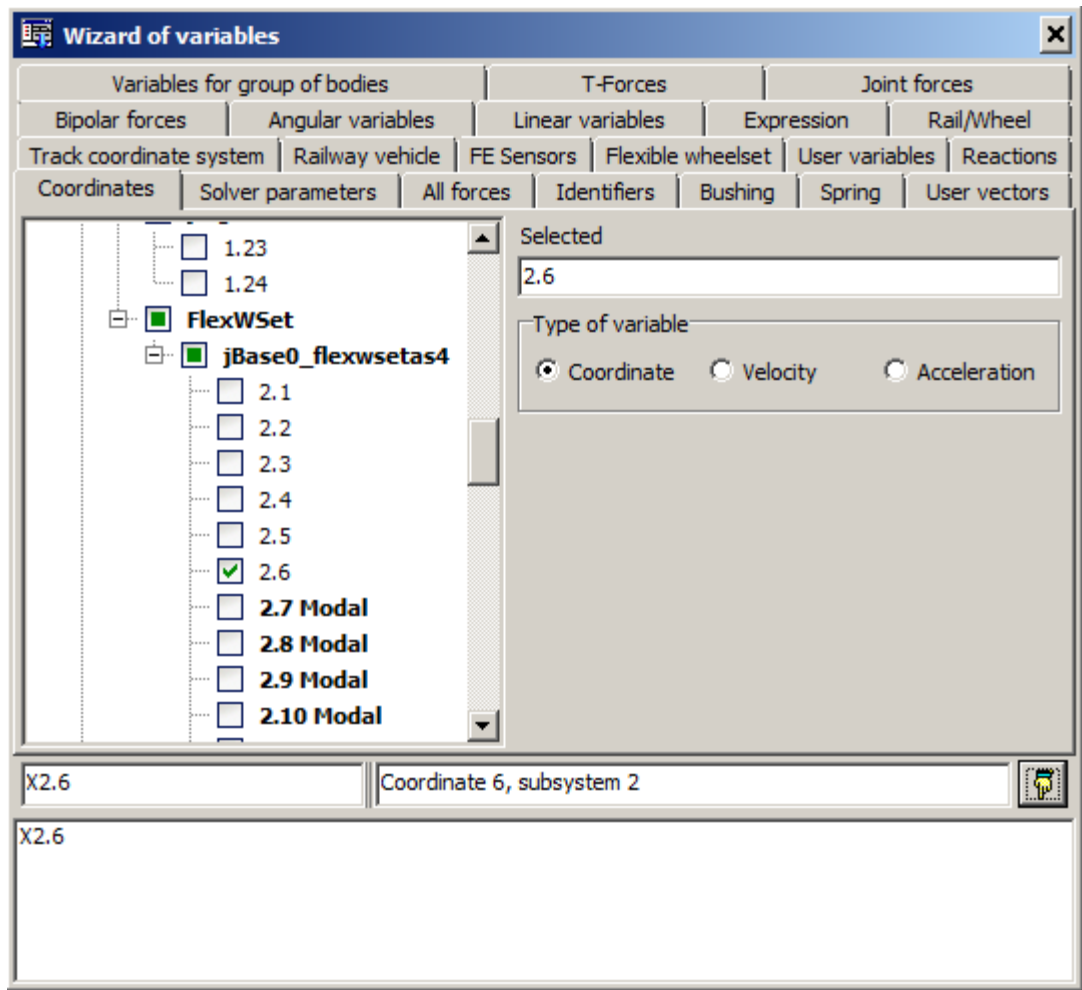
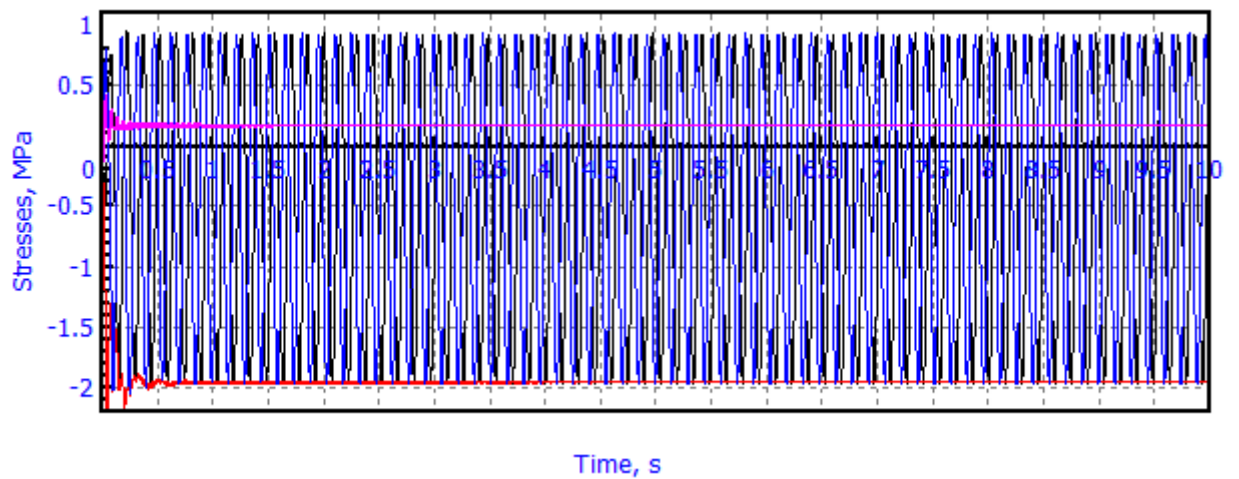

Figure 28.50. Creating the variable for calculation of the rotation angle of the wheelset around the axle



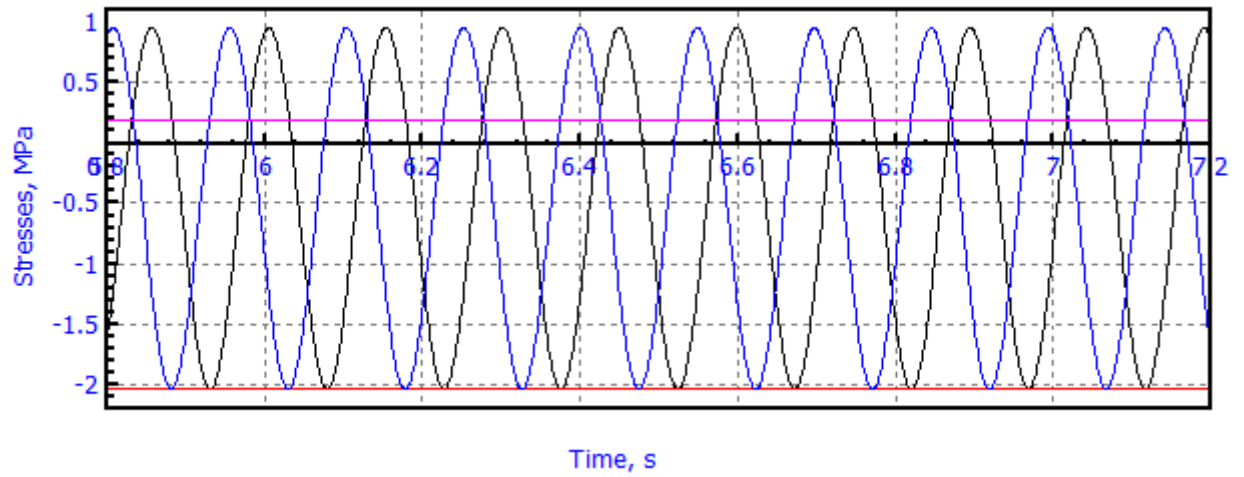

Figure 28.51. Radial stresses in the nodes when the railcar moves in straight track with the speed 80 km/h. Colors of the graphs are similar to Figure 28.49.

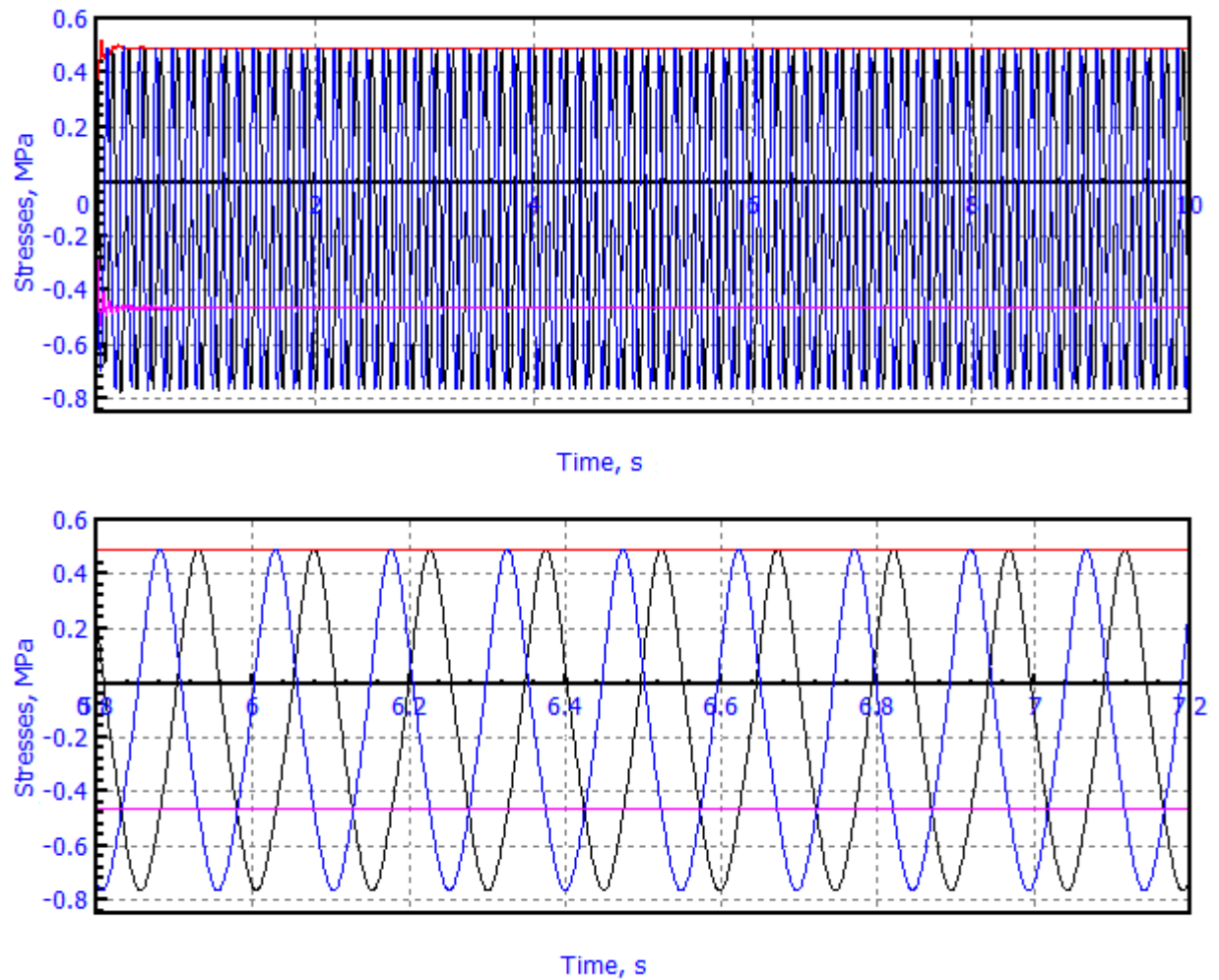

Figure 28.52. Tangential stresses in the nodes-sensors when the railcar moves in straight track with the speed 80 km/h. Graphs colors are similar to Figure 28.49.

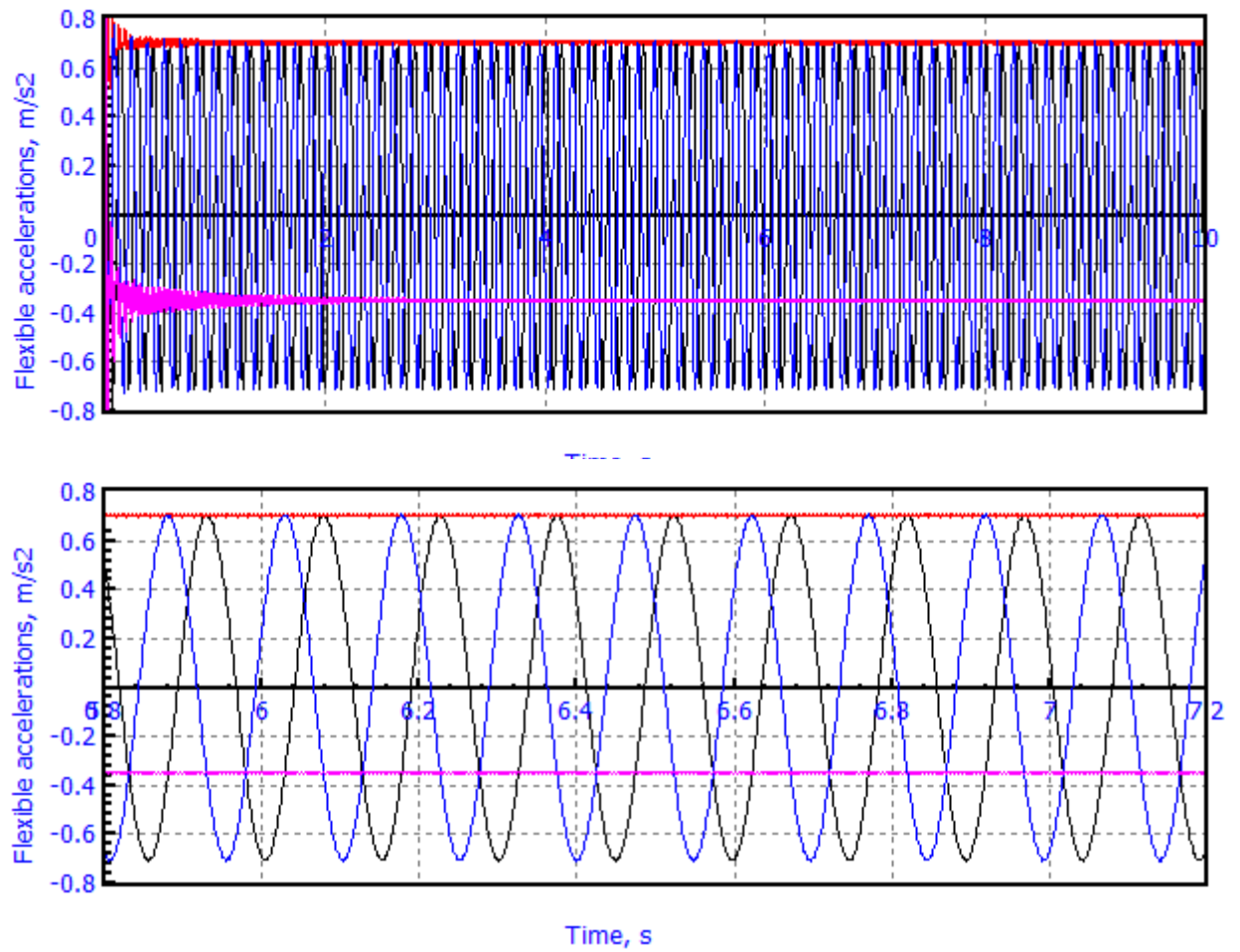

Figure 28.53. Radial flexible accelerations in the nodes-sensors when the railcar moves in straight track with the speed 80 km/h. Graphs colors are similar to Figure 28.49.

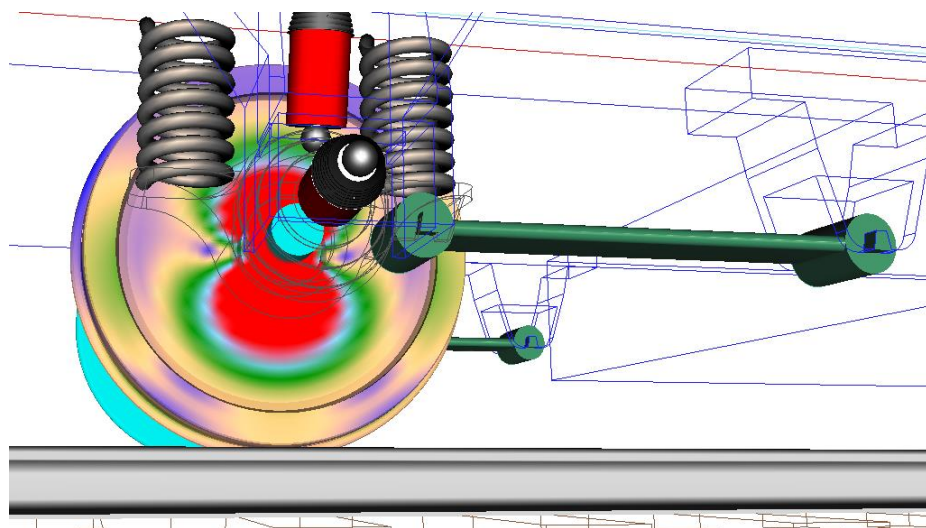

Figure 28.54. Painting the left wheel in accordance with the equivalent stresses

### 28.6.2.4. Motion in curvilinear track taking into account irregularities

The motion trajectory of the railcar in curvilinear track sections is specified after the choice **Curve** for **Track type** on tab **Rail/Wheel->Track->Macrogeometry** of **Object simulation inspector**. The curve parameters using in this numerical experiment are presented in Figure 28.55. The description of the curve geometry and used designations are presented in p. 8.2.1.2 “Geometry of curve” of [Chapter 8](#).

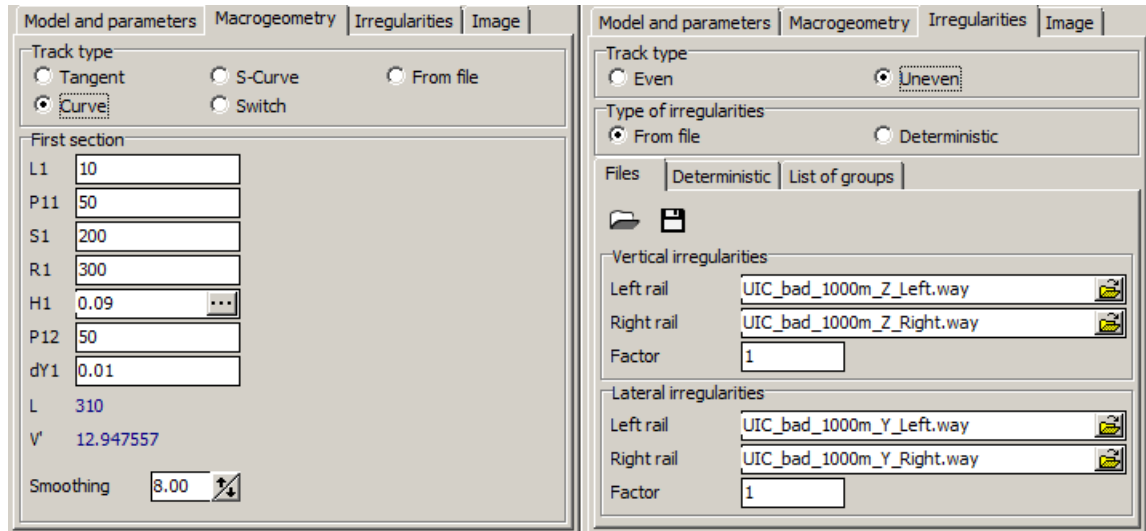



Figure 28.55. Settings curvilinear track and irregularities

The track irregularities are defined on **Irregularities** tab. File `.\rw\uic_bad_1000m.tig` describing the horizontal and vertical irregularities is chosen by button  (Figure 28.55). This file is included in **UM** installation package. In this case, the irregularities correspond to the track of bad quality according to UIC standard.

In accordance with the selected parameters, the end of the curvilinear section with the constant radius  $R1=300$  meters is placed approximately on 260 meters of track length. It takes about 11.7 seconds to pass this way moving with the speed 80 km/h. Let us set 13 seconds for simulation time and run the numerical integration.

The simulation results are presented in the figures below.

It is proposed to analyze wheelset dynamics using inertial and flexible tracks as well as Euler model type without assistant.

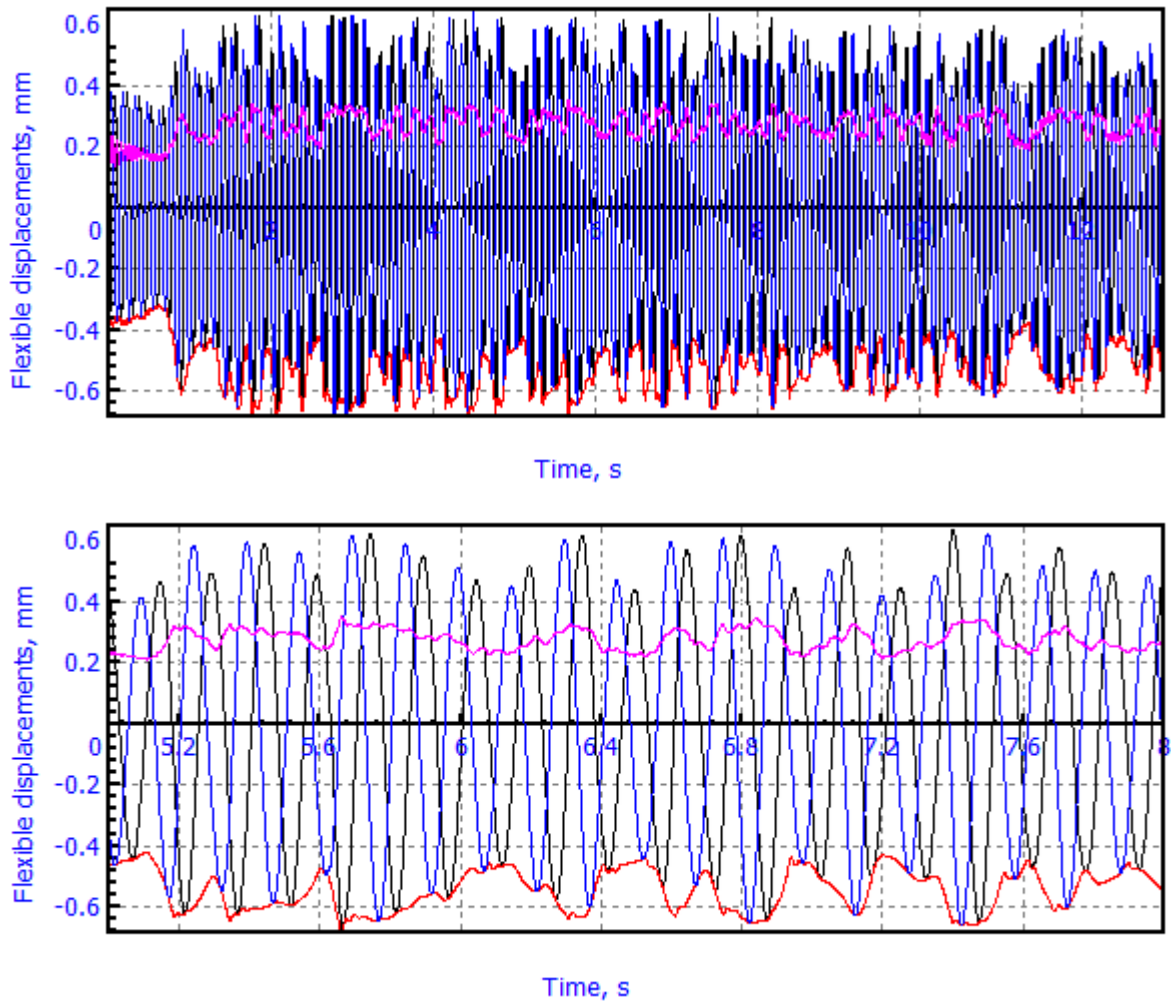

Figure 28.56. Flexible radial displacements of nodes-sensors when the railcar moves in curvilinear irregular track with the speed 80 km/h

- – Node 14372, Lagrange approach; ■ – Node 14372, Euler approach;
- – Node 23852, Lagrange approach; ■ – Node 23852, Euler approach.

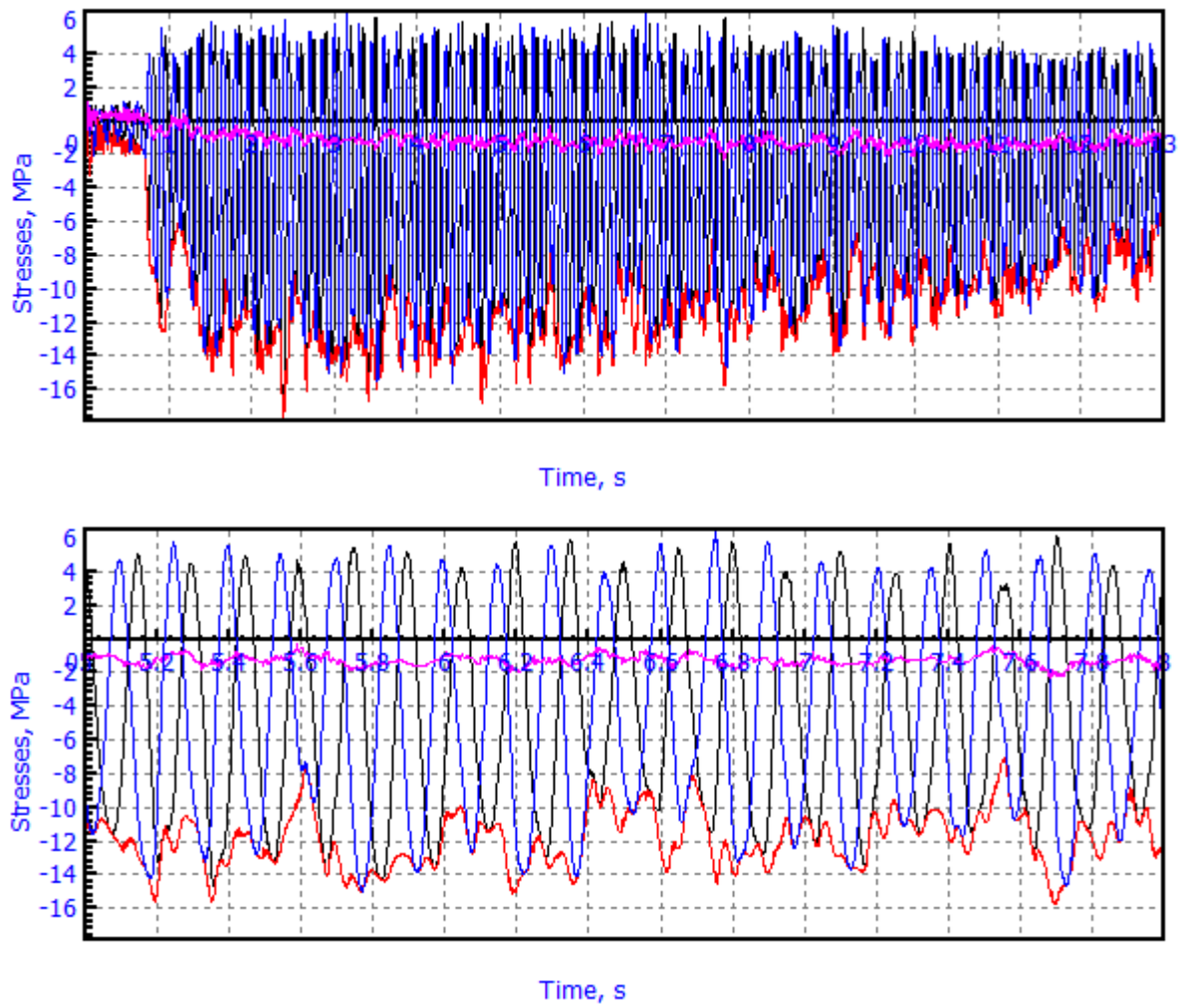

Figure 28.57. Radial stresses in nodes-sensors when the railcar moves in curvilinear irregular track with the speed 80 km/h. Graphs colors are similar to Figure 28.56.

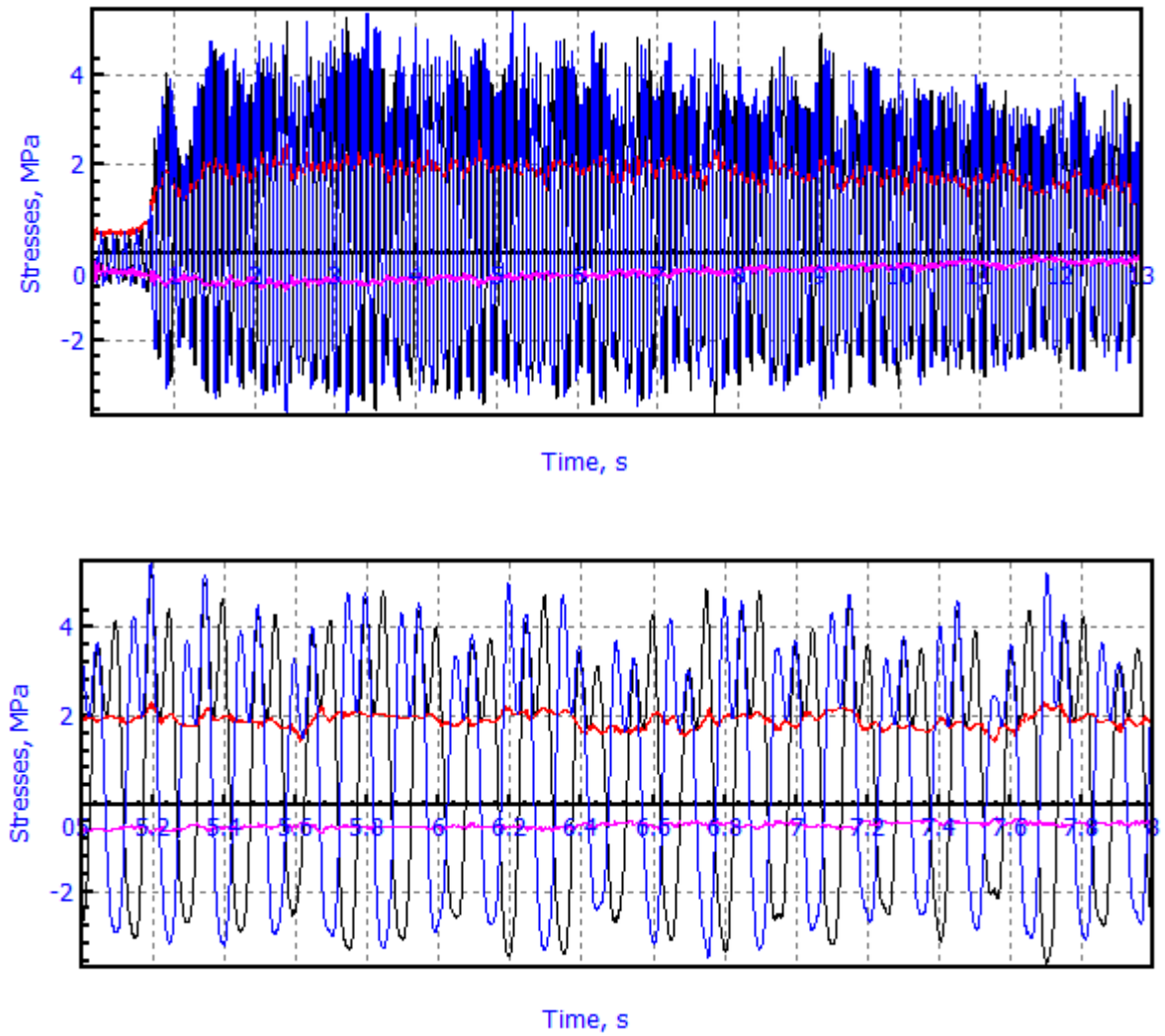

Figure 28.58. Tangential stresses in the nodes-sensors when the railcar moves in curvilinear irregular track with the speed 80 km/h. Graphs colors are similar to Figure 28.56.

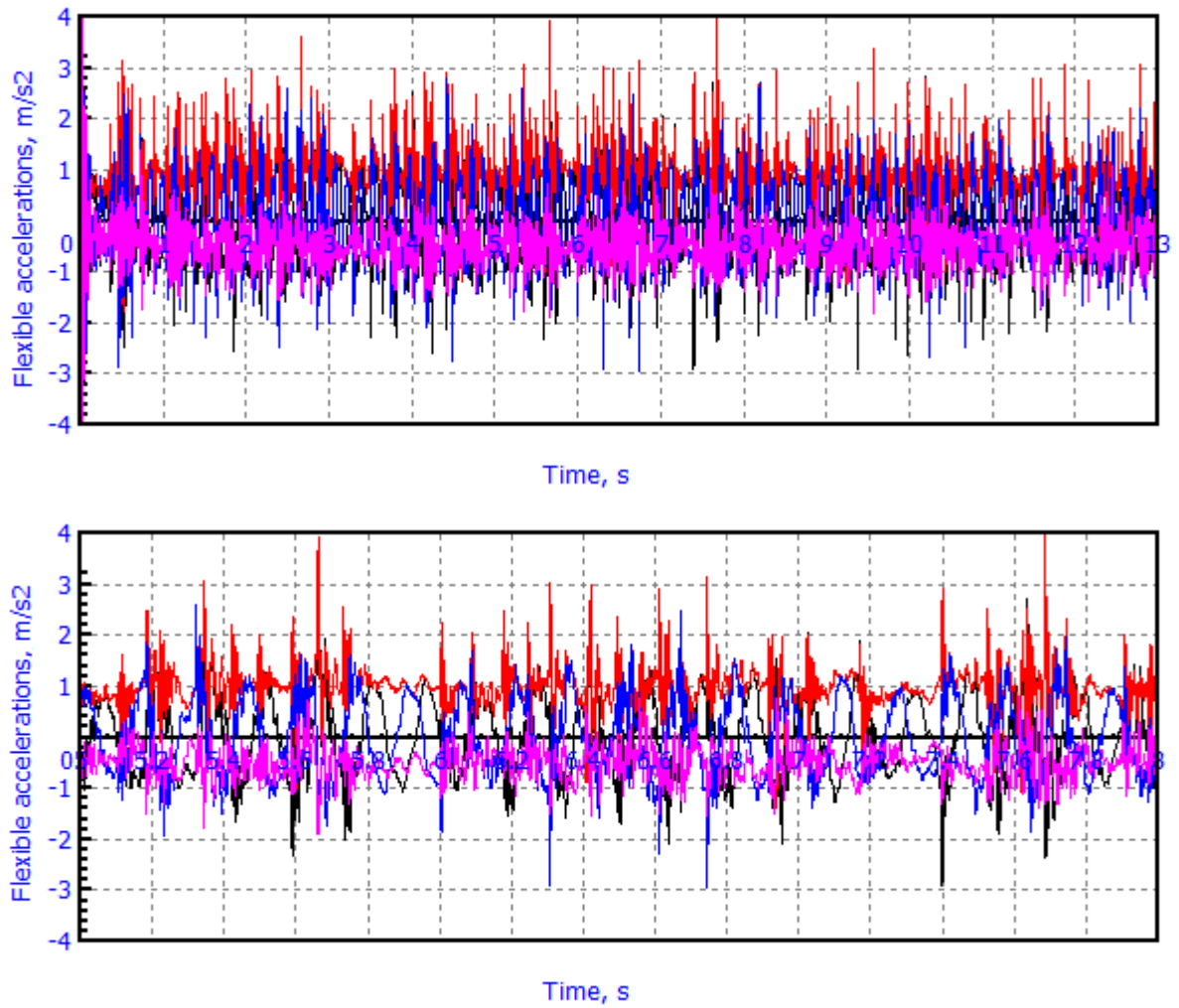

Figure 28.59. Tangential accelerations in the nodes-sensors when the railcar moves in curvilinear irregular track with the speed 80 km/h. Graphs colors are similar to Figure 28.56.